

Graduate Texts in Mathematics

James W. Vick

Homology Theory

**An Introduction to
Algebraic Topology**

Second Edition



Springer-Verlag

James W. Vick

Homology Theory

An Introduction to Algebraic Topology

Second Edition

With 78 Illustrations



Springer-Verlag

New York Berlin Heidelberg London Paris
Tokyo Hong Kong Barcelona Budapest

James W. Vick
Department of Mathematics
The University of Texas at Austin
Austin, TX 78713-7699
USA

Editorial Board

J.H. Ewing
Department of
Mathematics
Indiana University
Bloomington, IN 47405
USA

F.W. Gehring
Department of
Mathematics
University of Michigan
Ann Arbor, MI 48109
USA

P.R. Halmos
Department of
Mathematics
Santa Clara University
Santa Clara, CA 95053
USA

Mathematics Subject Classifications (1991): 55-01, 55N10, 57M10

Library of Congress Cataloging-in-Publication Data

Vick, James W.

Homology theory: an introduction to algebraic topology 2nd ed / James W. Vick.
p. cm.—(Graduate texts in mathematics)

Originally published: New York: Academic Press, c1973. (Pure and
applied mathematics; v. 53).

Includes bibliographical references and index.

ISBN 0-387-94126-6 (New York: alk. paper).—ISBN 3-540-94126-6
(Berlin: alk. paper)

1. Homology theory. I. Title. II. Series.

QA612.3.V53 1994

514'.23—dc20

93-5255

Printed on acid-free paper.

The first edition of this book was published by Academic Press, New York, © 1973.

© 1994 Springer-Verlag New York Inc.

All rights reserved. This work may not be translated or copied in whole or in part without the written permission of the publisher (Springer-Verlag New York, Inc., 175 Fifth Avenue, New York, NY 10010, USA), except for brief excerpts in connection with reviews or scholarly analysis. Use in connection with any form of information storage and retrieval, electronic adaptation, computer software, or by similar or dissimilar methodology now known or hereafter developed is forbidden.

The use of general descriptive names, trade names, trademarks, etc., in this publication, even if the former are not especially identified, is not to be taken as a sign that such names, as understood by the Trade Marks and Merchandise Marks Act, may accordingly be used freely by anyone.

Production coordinated by TechEdit Production Services and managed by Natalie Johnson; manufacturing supervised by Genieve Shaw.

Typeset by Asco Trade Typesetting Ltd., Hong Kong.

Printed and bound by R.R. Donnelley & Sons, Harrisonburg, VA.

Printed in the United States of America.

9 8 7 6 5 4 3 2 1

ISBN 0-387-94126-6 Springer-Verlag New York Berlin Heidelberg

ISBN 3-540-94126-6 Springer-Verlag Berlin Heidelberg New York

to Niki, Todd, and Stuart

Preface to the Second Edition

The 20 years since the publication of this book have been an era of continuing growth and development in the field of algebraic topology. New generations of young mathematicians have been trained, and classical problems have been solved, particularly through the application of geometry and knot theory. Diverse new resources for introductory coursework have appeared, but there is persistent interest in an intuitive treatment of the basic ideas.

This second edition has been expanded through the addition of a chapter on covering spaces. By analysis of the lifting problem it introduces the fundamental group and explores its properties, including Van Kampen's Theorem and the relationship with the first homology group. It has been inserted after the third chapter since it uses some definitions and results included prior to that point. However, much of the material is directly accessible from the same background as Chapter 1, so there would be some flexibility in how these topics are integrated into a course.

The Bibliography has been supplemented by the addition of selected books and historical articles that have appeared since 1973.

Preface to the First Edition

During the past twenty-five years the field of algebraic topology has experienced a period of phenomenal growth and development. Along with the increasing number of students and researchers in the field and the expanding areas of knowledge have come new applications of the techniques and results of algebraic topology in other branches of mathematics. As a result there has been a growing demand for an introductory course in algebraic topology for students in algebra, geometry, and analysis, as well as for those planning further work in topology.

This book is designed as a text for such a course as well as a source for individual reading and study. Its purpose is to present as clearly and concisely as possible the basic techniques and applications of homology theory. The subject matter includes singular homology theory, attaching spaces and finite CW complexes, cellular homology, the Eilenberg–Steenrod axioms, cohomology, products, and duality and fixed-point theory for topological manifolds. The treatment is highly intuitive with many figures to increase the geometric understanding. Generalities have been avoided whenever it was felt that they might obscure the essential concepts.

Although the prerequisites are limited to basic algebra (abelian groups) and general topology (compact Hausdorff spaces), a number of the classical applications of algebraic topology are given in the first chapter. Rather than devoting an initial chapter to homological algebra, these concepts have been integrated into the text so that the motivation for the constructions is more apparent. Similarly the exercises have been spread throughout in order to exploit techniques or reinforce concepts.

At the close of the book there are three bibliographical lists. The first includes all works referenced in the text. The second is an extensive list of

books and notes in algebraic topology and related fields, and the third is a similar list of survey and expository articles. It was felt that these would best serve the student, teacher, and reader in offering accessible sources for further reading and study.

Acknowledgments

Acknowledgments to the First Edition

The original manuscript for this book was a set of lecture notes from Math 401–402 taught at Princeton University in 1969–1970. However, much of the technique and organization of the first four chapters may be traced to courses in algebraic topology taught by Professor E.E. Floyd at the University of Virginia in 1964–1965 and 1966–1967. The author was one of the fortunate students who have been introduced to the subject by such a masterful teacher. Any compliments that this book may merit should justifiably be directed first to Professor Floyd.

The author wishes to express his appreciation to the students and faculty of Princeton University and the University of Texas who have taken an interest in these notes, contributed to their improvement, and encouraged their publication. The typing of the manuscript by the secretarial staff of the Mathematics Department at the University of Texas was excellent, and particular thanks are due to Diane Schade, who types the majority of it. Many helpful improvements and corrections in the original manuscript were suggested by Professor Peter Landweber.

Finally, the author expresses a deep sense of gratitude to his wife and family for their boundless patience and understanding over years during which this book has evolved.

Acknowledgments to the Second Edition

When John Ewing inquired as to my interest in reissuing this book with Springer-Verlag, I was doubly pleased. First, there was interest in making it

available once more since it went out of print some years ago. Second, I would be offered the chance to include new topics that would give it broader appeal. I am grateful to John and to Springer-Verlag for their interest.

The intervening 20 years at the University of Texas have been superb. My colleagues among the faculty, staff, and students have provided much encouragement and support. In particular, I appreciate the opportunity to work jointly on research with John Alexander, Gary Hamrick, and Pierre Conner.

The essential reason for these happy years is conveyed in the dedication: Niki, Todd, and Stuart. From kindergarten through graduate school, from little league through weddings, and from professional success back to a doctoral program, there have been enough great memories to last a lifetime.

Contents

Preface to the Second Edition	vii
Preface to the First Edition	ix
Acknowledgments	xi
CHAPTER 1	
Singular Homology Theory	1
CHAPTER 2	
Attaching Spaces with Maps	35
CHAPTER 3	
The Eilenberg–Steenrod Axioms	65
CHAPTER 4	
Covering Spaces	85
CHAPTER 5	
Products	120
CHAPTER 6	
Manifolds and Poincaré Duality	143
CHAPTER 7	
Fixed-Point Theory	186
Appendix I	211
Appendix II	218

References	227
Bibliography	229
Books and Historical Articles Since 1973	229
Books and Notes	230
Survey and Expository Articles	234
Index	239

CHAPTER 1

Singular Homology Theory

The purpose of this chapter is to introduce the singular homology theory of an arbitrary topological space. Following the definitions and a proof of homotopy invariance, the essential computational tool (Theorem 1.14) is stated. Its proof is deferred to Appendix I so that the exposition need not be interrupted by its involved constructions. The Mayer–Vietoris sequence is noted as an immediate corollary of this theorem, and then applied to compute the homology groups of spheres. These results are applied to prove a number of classical theorems: the nonretractibility of a disk onto its boundary, the Brouwer fixed-point theorem, the nonexistence of vector fields on even-dimensional spheres, the Jordan–Brouwer separation theorem and the Brouwer theorem on the invariance of domain.

If x and y are points in \mathbb{R}^n , define the *segment* from x to y to be $\{(1-t)x + ty \mid 0 \leq t \leq 1\}$. A subset $C \subseteq \mathbb{R}^n$ is *convex* if, given x and y in C , the segment from x to y lies entirely in C . Note that an arbitrary intersection of convex sets is convex. If $A \subseteq \mathbb{R}^n$, the *convex hull* of A is the intersection of all convex sets in \mathbb{R}^n which contain A .

A p -simplex s in \mathbb{R}^n is the convex hull of a collection of $(p+1)$ points $\{x_0, \dots, x_p\}$ in \mathbb{R}^n in which $x_1 - x_0, \dots, x_p - x_0$ form a linearly independent set. Note that this is independent of the designation of which point is x_0 .

1.1 Proposition. *Let $\{x_0, \dots, x_p\} \subseteq \mathbb{R}^n$. Then the following are equivalent:*

- (a) $x_1 - x_0, \dots, x_p - x_0$ are linearly independent;
- (b) if $\sum s_i x_i = \sum t_i x_i$ and $\sum s_i = \sum t_i$, then $s_i = t_i$ for $i = 0, \dots, p$.

Proof. (a) \Rightarrow (b): If $\sum s_i x_i = \sum t_i x_i$ and $\sum s_i = \sum t_i$, then

$$\begin{aligned} 0 &= \sum_{i=0}^p (s_i - t_i)x_i = \sum_{i=0}^p (s_i - t_i)x_i - \left[\sum_{i=0}^p (s_i - t_i) \right] x_0 \\ &= \sum_{i=1}^p (s_i - t_i)(x_i - x_0). \end{aligned}$$

By the linear independence of $x_1 - x_0, \dots, x_p - x_0$ it follows that $s_i = t_i$ for $i = 1, \dots, p$. Finally, this implies $s_0 = t_0$ since $\sum s_i = \sum t_i$.

(b) \Rightarrow (a): If $\sum_{i=1}^p (t_i)(x_i - x_0) = 0$, then $\sum_{i=1}^p t_i x_i = (\sum_{i=1}^p t_i)x_0$ and by (b) the coefficients t_1, \dots, t_n must all be zero. This proves linear independence. \square

Let s be a p -simplex in \mathbb{R}^n and consider the set of all points of the form $t_0 x_0 + t_1 x_1 + \dots + t_p x_p$, where $\sum t_i = 1$ and $t_i \geq 0$ for each i . Note that this is the convex hull of the set $\{x_0, \dots, x_p\}$ and hence from Proposition 1.1 we have the following:

1.2 Proposition. *If the p -simplex s is the convex hull of $\{x_0, \dots, x_p\}$, then every point of s has a distinct unique representation in the form $\sum t_i x_i$, where $t_i \geq 0$ for all i and $\sum t_i = 1$.* \square

The points x_i are the *vertices* of s . This proposition allows us to associate the points of s with $(p + 1)$ -tuples (t_0, t_1, \dots, t_p) with a suitable choice of the coordinates t_i .

EXERCISE 1. Let y be a point in s . Then y is a vertex of s if and only if y is not an interior point of any segment lying in s .

If the vertices of s have been given a specific order, then s is an *ordered simplex*. So let s be an ordered simplex with vertices x_0, x_1, \dots, x_p . Define σ_p to be the set of all points $(t_0, t_1, \dots, t_p) \in \mathbb{R}^{p+1}$ with $\sum t_i = 1$ and $t_i \geq 0$ for each i . If a function

$$f: \sigma_p \rightarrow s$$

is given by $f(t_0, \dots, t_p) = \sum t_i x_i$, then f is continuous. Moreover, from the uniqueness of representations and the fact that σ_p and s are compact Hausdorff spaces it follows that f is a homeomorphism. Thus, each ordered p -simplex is a natural homeomorphic image of σ_p . Note that σ_p is a p -simplex with vertices $x'_0 = (1, 0, \dots, 0)$, $x'_1 = (0, 1, \dots, 0)$, \dots , $x'_p = (0, \dots, 0, 1)$. σ_p is called the *standard p -simplex* with natural ordering.

Let X be a topological space. A *singular p -simplex* in X is a continuous function

$$\phi: \sigma_p \rightarrow X.$$

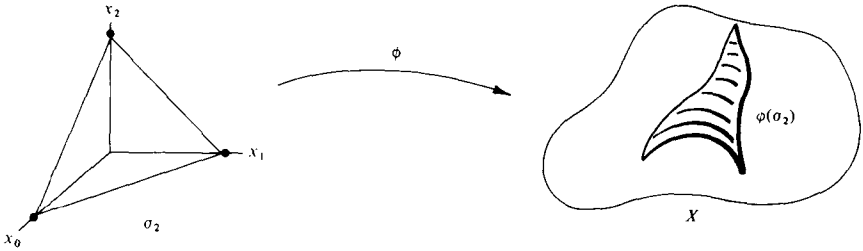

Figure 1.1

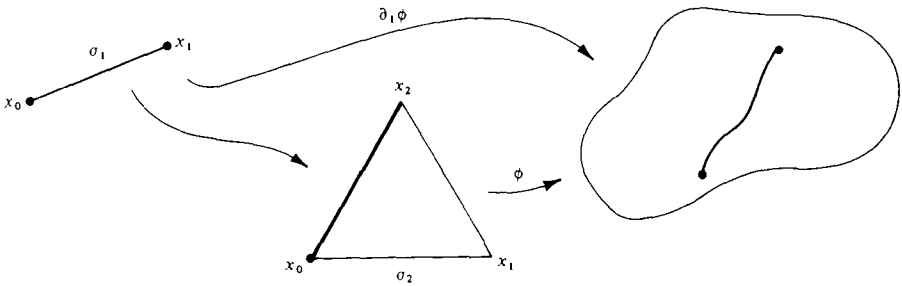

Figure 1.2

Note that the singular 0-simplices may be identified with the points of X , the singular 1-simplices with the paths in X , and so forth.

If ϕ is a singular p -simplex and i is an integer with $0 \leq i \leq p$, define $\partial_i(\phi)$, a singular $(p - 1)$ -simplex in X , by

$$\partial_i\phi(t_0, \dots, t_{p-1}) = \phi(t_0, t_1, \dots, t_{i-1}, 0, t_i, \dots, t_{p-1}).$$

$\partial_i\phi$ is the i th face of ϕ .

For example, let ϕ be a singular 2-simplex in X (Figure 1.1). Then, $\partial_1\phi$ is given by the composition shown in Figure 1.2. That is, to compute $\partial_i\phi$ we embed σ_{p-1} into σ_p opposite the i th vertex, using the usual ordering of vertices, and then go into X via ϕ .

If $f: X \rightarrow Y$ is a continuous function and ϕ is a singular p -simplex in X , define a singular p -simplex $f_*(\phi)$ in Y by $f_*(\phi) = f \circ \phi$. Note that if $g: Y \rightarrow W$ is continuous and $\text{id}: X \rightarrow X$ is the identity map,

$$(g \circ f)_*(\phi) = g_*(f_*(\phi)) \quad \text{and} \quad (\text{id})_*(\phi) = \phi.$$

An abelian group G is *free* if there exists a subset $A \subseteq G$ such that every element g in G has a unique representation

$$g = \sum_{x \in A} n_x \cdot x,$$

where n_x is an integer and equal to zero for all but finitely many x in A . The set A is a *basis* for G .

Given an arbitrary set A we may construct a free abelian group with basis A in the following manner. Let $F(A)$ be the set of all functions f from A into the integers such that $f(x) \neq 0$ for only a finite number of elements of A . Define an operation in $F(A)$ by $(f + g)(x) = f(x) + g(x)$. Then $F(A)$ is an abelian group. For any $a \in A$ define a function f_a in $F(A)$ by

$$f_a(x) = \begin{cases} 1 & \text{if } x = a \\ 0 & \text{otherwise.} \end{cases}$$

Then $\{f_a | a \in A\}$ is a basis for $F(A)$ as a free abelian group. Identifying a with f_a completes the construction.

For example, let $G = \{(n_1, n_2, \dots) | n_i \text{ is an integer, eventually } 0\}$. Then G is an abelian group under coordinatewise addition, and furthermore it is free with basis

$$(1, 0, \dots), (0, 1, 0, \dots), (0, 0, 1, 0, \dots), \dots$$

For convenience we say that if $G = 0$, then G is a free abelian group with empty basis.

Note that if G is free abelian with basis A and H is an abelian group, then every function $f: A \rightarrow H$ can be uniquely extended to a homomorphism $f: G \rightarrow H$.

If X is a topological space define $S_n(X)$ to be the free abelian group whose basis is the set of all singular n -simplices of X . An element of $S_n(X)$ is called a *singular n -chain* of X and has the form

$$\sum_{\phi} n_{\phi} \cdot \phi,$$

where n_{ϕ} is an integer, equal to zero for all but a finite number of ϕ .

Since the i th face operator ∂_i is a function from the set of singular n -simplices to the set of singular $(n - 1)$ -simplices, there is a unique extension to a homomorphism

$$\partial_i: S_n(X) \rightarrow S_{n-1}(X)$$

given by $\partial_i(\sum n_{\phi} \cdot \phi) = \sum n_{\phi} \cdot \partial_i \phi$. Define the *boundary operator* to be the homomorphism

$$\partial: S_n(X) \rightarrow S_{n-1}(X)$$

given by

$$\partial = \partial_0 - \partial_1 + \partial_2 + \dots + (-1)^n \partial_n = \sum_{i=0}^n (-1)^i \partial_i.$$

1.3 Proposition. *The composition $\partial \circ \partial$ in*

$$S_n(X) \xrightarrow{\partial} S_{n-1}(X) \xrightarrow{\partial} S_{n-2}(X)$$

is zero.

EXERCISE 2. Prove Proposition 1.3. □

Geometrically this statement merely says that the boundary of any n -chain is an $(n - 1)$ -chain having no boundary. It is this basic property which leads to the definition of the homology groups. An element $c \in S_n(X)$ is an n -cycle if $\partial(c) = 0$. An element $d \in S_n(X)$ is an n -boundary if $d = \partial(e)$ for some $e \in S_{n+1}(X)$. Since ∂ is a homomorphism, its kernel, the set of all n -cycles, is a subgroup of $S_n(X)$ denoted by $Z_n(X)$. Similarly the image of ∂ in $S_n(X)$ is the subgroup $B_n(X)$ of all n -boundaries.

Note that Proposition 1.3 implies that $B_n(X) \subseteq Z_n(X)$ is a subgroup. The quotient group

$$H_n(X) = Z_n(X)/B_n(X)$$

is the n th *singular homology group* of X . The geometric motivation for this algebraic construction is evident; the objects we wish to study are cycles in topological spaces. However, in using singular cycles, the collection of all such is too vast to be effectively studied. The natural approach is then to restrict our attention to equivalence classes of cycles under the relation that two cycles are equivalent if their difference forms a boundary of a chain of one dimension higher.

This algebraic technique is a standard construction in homological algebra. A *graded* (abelian) *group* G is a collection of abelian groups $\{G_i\}$ indexed by the integers with componentwise operation. If G and G' are graded groups, a homomorphism

$$f: G \rightarrow G'$$

is a collection of homomorphisms $\{f_i\}$, where

$$f_i: G_i \rightarrow G'_{i+r}$$

for some fixed integer r . r is then called the *degree* of f . A subgroup $H \subseteq G$ of a graded group is a *graded group* $\{H_i\}$ where H_i is a subgroup of G_i . The quotient group G/H is the *graded group* $\{G_i/H_i\}$.

A *chain complex* is a sequence of abelian groups and homomorphisms

$$\cdots \xrightarrow{\partial_{n+1}} C_n \xrightarrow{\partial_n} C_{n-1} \xrightarrow{\partial_{n-1}} \cdots$$

in which the composition $\partial_{n-1} \circ \partial_n = 0$ for each n . Equivalently a chain complex is a graded group $C = \{C_i\}$ together with a homomorphism $\partial: C \rightarrow C$ of degree -1 such that $\partial \circ \partial = 0$. If C and C' are chain complexes with boundary operators ∂ and ∂' , a chain map from C to C' is a homomorphism

$$\Phi: C \rightarrow C'$$

of degree zero such that $\partial' \circ \Phi_n = \Phi_{n-1} \circ \partial$ for each n . (Note that the requirement that Φ have degree zero is unnecessary. It is stated here only as a convenience since all chain maps we will consider have this property.) Denoting by $Z_*(C)$ and $B_*(C)$ the kernel and image of ∂ , respectively, the

homology of C is the graded group

$$H_*(C) = Z_*(C)/B_*(C).$$

Note that if Φ is a chain map,

$$\Phi(Z_*(C)) \subseteq Z_*(C') \quad \text{and} \quad \Phi(B_*(C)) \subseteq B_*(C').$$

Therefore, Φ induces a homomorphism on homology groups

$$\Phi_*: H_*(C) \rightarrow H_*(C').$$

In this sense the graded group $S_*(X) = \{S_i(X)\}$ becomes a chain complex under the boundary operator ∂ , so that the homology group of X is the homology of this chain complex. If $f: X \rightarrow Y$ is a continuous function and ϕ is a singular n -simplex in X , there is the singular n -simplex $f_\#(\phi) = f \circ \phi$ in Y . This extends uniquely to a homomorphism

$$f_\#: S_n(X) \rightarrow S_n(Y) \quad \text{for each } n.$$

To show that $f_\#$ is a chain map from $S_*(X)$ to $S_*(Y)$ it must be checked that the following rectangle commutes:

$$\begin{array}{ccc} S_n(X) & \xrightarrow{f_\#} & S_n(Y) \\ \downarrow \partial & & \downarrow \partial \\ S_{n-1}(X) & \xrightarrow{f_\#} & S_{n-1}(Y) \end{array}$$

First note that it is sufficient to check that this is true on singular n -simplices ϕ , and second, observe that it is sufficient to show $\partial_i f_\#(\phi) = f_\# \partial_i(\phi)$. Now

$$f_\# \partial_i(\phi)(t_0, \dots, t_{n-1}) = f(\phi(t_0, \dots, t_{i-1}, 0, t_i, \dots, t_{n-1}))$$

and

$$\begin{aligned} \partial_i f_\#(\phi)(t_0, \dots, t_{n-1}) &= f_\#(\phi)(t_0, \dots, t_{i-1}, 0, t_i, \dots, t_{n-1}) \\ &= f(\phi(t_0, \dots, t_{i-1}, 0, t_i, \dots, t_{n-1})). \end{aligned}$$

Thus, $f_\#: S_*(X) \rightarrow S_*(Y)$ is a chain map and there is induced a homomorphism of degree zero

$$f_*: H_*(X) \rightarrow H_*(Y).$$

Note that this is suitably functorial in the sense that for $g: Y \rightarrow W$ a continuous function and $\text{id}: X \rightarrow X$ the identity, $(g \circ f)_* = g_* \circ f_*$ and id_* is the identity homomorphism.

As a first example take $X = \text{point}$. Then for each $p \geq 0$ there exists a unique singular p -simplex $\phi_p: \sigma_p \rightarrow X$. Note further that for $p > 0$, $\partial_i \phi_p = \phi_{p-1}$. So consider the chain complex

$$\cdots \rightarrow S_2(\text{pt}) \rightarrow S_1(\text{pt}) \rightarrow S_0(\text{pt}) \rightarrow 0.$$

Each $S_n(\text{pt})$ is an infinite cyclic group generated by ϕ_n . The boundary opera-

tor is given by

$$\partial\phi_n = \sum_{i=0}^n (-1)^i \partial_i \phi_n = \sum_{i=0}^n (-1)^i \phi_{n-1}.$$

Thus, $\partial\phi_{2n-1} = 0$ and $\partial\phi_{2n} = \phi_{2n-1}$ for $n > 0$. Applying this to the chain complex it is evident that

$$Z_n(\text{pt}) = B_n(\text{pt}) \quad \text{for } n > 0.$$

However, $Z_0(\text{pt}) = S_0(\text{pt})$ is infinite cyclic, whereas $B_0(\text{pt}) = 0$. Therefore, we conclude that the homology groups of a point are given by

$$H_n(\text{pt}) = \begin{cases} Z & \text{if } n = 0 \\ 0 & \text{if } n > 0. \end{cases}$$

A space X is *pathwise connected* if given $x, y \in X$, there is a continuous function

$$\psi: [0, 1] \rightarrow X$$

such that $\psi(0) = x$ and $\psi(1) = y$. Note that instead of $[0, 1]$ we could have used σ_1 .

Suppose that X is a pathwise connected space, and consider the portion of the singular chain complex of X given by

$$S_1(X) \xrightarrow{\partial} S_0(X) \rightarrow 0.$$

Now $S_0(X) = Z_0(X)$, which may be viewed as the free abelian group generated by the points of X . That is $Z_0(X) = F(X)$. Hence, an element y of $Z_0(X)$ has the form

$$y = \sum_{x \in X} n_x \cdot x,$$

where the n_x are integers, all but finitely many equal to zero.

On the other hand, $S_1(X)$ may be viewed as the free abelian group generated by the set of all paths in X . If the vertices of σ_1 are v_0 and v_1 and ϕ is a singular 1-simplex in X , then

$$\partial\phi = \phi(v_1) - \phi(v_0) \in Z_0(X).$$

Define a homomorphism $\alpha: S_0(X) \rightarrow Z$ by $\alpha(\sum n_x \cdot x) = \sum n_x$. Note that if X is nonempty, then α is an epimorphism. Since for any singular 1-simplex ϕ in X , $\alpha(\partial\phi) = \alpha(\phi(v_1) - \phi(v_0)) = 0$, it follows that $B_0(X)$ is contained in the kernel of α .

Conversely, suppose that $n_1 x_1 + \dots + n_k x_k \in Z_0(X)$ with $\sum n_i = 0$. Pick any point $x \in X$ and note that for each i there is a singular 1-simplex $\phi_i: \sigma_1 \rightarrow X$ with $\partial_0(\phi_i) = x_i$ and $\partial_1(\phi_i) = x$. Taking the singular 1-chain $\sum n_i \phi_i$ in $S_1(X)$ we have $\partial(\sum n_i \phi_i) = \sum n_i x_i - (\sum n_i) x = \sum n_i x_i$. Therefore, the kernel of α is contained in $B_0(X)$. This proves that the kernel of α equals $B_0(X)$ and we conclude the following:

1.4 Proposition. *If X is a nonempty pathwise-connected space, then*

$$H_0(X) \approx Z. \quad \square$$

Let A be a set and suppose that for each $\alpha \in A$ there is given an abelian group G_α . Define an abelian group $\sum_{\alpha \in A} G_\alpha$ as follows: the elements are all functions

$$f: A \rightarrow \bigcup_{\alpha \in A} G_\alpha$$

such that $f(\alpha) \in G_\alpha$ for each α , and $f(\alpha) = 0$ for all but finitely many elements $\alpha \in A$; the operation is defined by $(f + g)(\alpha) = f(\alpha) + g(\alpha)$. Setting $g_\alpha = f(\alpha) \in G_\alpha$ we write $f = (g_\alpha: \alpha \in A)$ and call the g_α the components of f . The group $\sum G_\alpha$ is the *weak direct sum* of the G_α 's. If the requirement that $f(\alpha) = 0$ for all but finitely many α is omitted, then the resulting group is the *strong direct sum* or *direct product* of the G_α 's, denoted $\prod_{\alpha \in A} G_\alpha$.

Note that if G is an abelian group and $\{G_\alpha\}_{\alpha \in A}$ is a family of subgroups of G such that $g \in G$ has a unique representation

$$g = \sum_{\alpha \in A} g_\alpha \quad \text{with } g_\alpha \in G_\alpha$$

and $g_\alpha = 0$ for all but finitely many α , then G is isomorphic to $\sum_{\alpha \in A} G_\alpha$.

Now for each $\alpha \in A$ suppose we have a chain complex C^α

$$\cdots \xrightarrow{\hat{c}_p^\alpha} C_p^\alpha \xrightarrow{\hat{c}_{p-1}^\alpha} C_{p-1}^\alpha \xrightarrow{\hat{c}_{p-2}^\alpha} \cdots.$$

Define a chain complex $\sum_{\alpha \in A} C^\alpha$ by taking $(\sum C^\alpha)_p = \sum C_p^\alpha$ and setting $\hat{c}_p(\sum c_\alpha) = (\sum \hat{c}_p^\alpha c_\alpha: \alpha \in A)$.

1.5 Lemma. $H_k(\sum C^\alpha) \approx \sum_\alpha H_k(C^\alpha)$.

Proof. Note that by the definition of the chain complex $\sum C^\alpha$ we have

$$Z_k(\sum C^\alpha) = \sum (Z_k(C^\alpha)) \quad \text{and} \quad B_k(\sum C^\alpha) = \sum (B_k(C^\alpha)).$$

Therefore

$$\begin{aligned} H_k(\sum C^\alpha) &= Z_k(\sum C^\alpha)/B_k(\sum C^\alpha) \\ &= \sum (Z_k(C^\alpha))/\sum (B_k(C^\alpha)) \\ &\approx \sum (Z_k(C^\alpha)/B_k(C^\alpha)) \\ &= \sum H_k(C^\alpha). \end{aligned} \quad \square$$

Let X be a topological space and for $x, y \in X$, set $x \sim y$ if there exists a path in X from x to y . It is evident that \sim is an equivalence relation, that is,

- (1) $x \sim x$,
- (2) $x \sim y$ and $y \sim z$ implies $x \sim z$,
- (3) $x \sim y$ implies $y \sim x$,

for all points $x, y,$ and z in X . Such a relation decomposes X into a collection of subsets, the equivalence classes, where x and y are in the same equivalence class if and only if $x \sim y$. For this specific relation on X the equivalence classes are called the *path components* of X . Note that if $x \in X$ the path component of X containing x is the maximal pathwise-connected subset of X containing x .

1.6 Proposition. *If X is a space and $\{X_\alpha: \alpha \in A\}$ are the path components of X , then*

$$H_k(X) \approx \sum_{\alpha \in A} H_k(X_\alpha).$$

Proof. There is a natural homomorphism

$$\Psi: \sum_{\alpha \in A} S_k(X_\alpha) \rightarrow S_k(X)$$

given by

$$\Psi\left(\left(\sum_{\phi_\alpha} n_{\phi_\alpha} \cdot \phi_\alpha\right): \alpha \in A\right) = \sum_{\alpha \in A} \left(\sum_{\phi_\alpha} n_{\phi_\alpha} \cdot \phi_\alpha\right).$$

Since the groups involved are free abelian, Ψ must be a monomorphism. To observe that Ψ is also an epimorphism, note first that if

$$\phi: \sigma_k \rightarrow X$$

is a singular k -simplex, then $\phi(\sigma_k)$ is contained in some X_α because σ_k is pathwise connected. Hence, to any such ϕ there is associated a unique $\phi_\alpha \in S_k(X_\alpha)$ with $\Psi(\phi_\alpha) = \phi$. Therefore, Ψ is an isomorphism for each k .

Moreover, Ψ is a chain map between chain complexes so that

$$H_k(X) \approx H_k\left(\sum_{\alpha \in A} S_\star(X_\alpha)\right).$$

Finally, it follows from Lemma 1.5 that

$$H_k\left(\sum_{\alpha \in A} S_\star(X_\alpha)\right) \approx \sum_{\alpha \in A} H_k(X_\alpha),$$

which completes the proof. \square

This proposition establishes the intrinsic “additive” property of singular homology theory. Since the homological properties of a space are completely determined by those of its path components, and the homological properties of any path component are independent of the properties of any other path component, we may restrict our attention to the study of pathwise-connected spaces.

Note that it follows from Propositions 1.6 and 1.4 that $H_0(X)$ is a free

abelian group whose basis is in a one-to-one correspondence with the path components of X .

1.7 Theorem. *If $f: X \rightarrow Y$ is a homeomorphism, then*

$$f_*: H_p(X) \rightarrow H_p(Y)$$

is an isomorphism for each p .

EXERCISE 3. Prove Theorem 1.7. □

The fact that this theorem, the topological invariance of the singular homology groups, is quite easy to prove is one of the major advantages of using singular homology theory.

1.8 Theorem. *If X is a convex subset of \mathbb{R}^n , then*

$$H_p(X) = 0 \quad \text{for } p > 0.$$

Proof. Assume $X \neq \emptyset$ and let $x \in X$ and $\phi: \sigma_p \rightarrow X$ be a singular p -simplex, $p \geq 0$. Then define a singular $(p+1)$ -simplex $\theta: \sigma_{p+1} \rightarrow X$ as follows:

$$\theta(t_0, \dots, t_{p+1}) = \begin{cases} (1 - t_0) \cdot \left(\phi \left(\frac{t_1}{1 - t_0}, \dots, \frac{t_{p+1}}{1 - t_0} \right) \right) + t_0 x & \text{for } t_0 < 1 \\ x & \text{for } t_0 = 1. \end{cases}$$

That is, we are setting

$$\theta(0, t_1, \dots, t_{p+1}) = \phi(t_1, \dots, t_{p+1}) \quad \text{and} \quad \theta(1, 0, \dots, 0) = x$$

and then taking line segments from t_0 to the face opposite t_0 linearly into the corresponding line segment in X (Figure 1.3). This construction is possible since X is convex.

From its definition θ is continuous except possibly at $(1, 0, \dots, 0)$. To check continuity there we must show that

$$\lim_{t_0 \rightarrow 1} \|\theta(t_0, \dots, t_{p+1}) - x\| = 0.$$

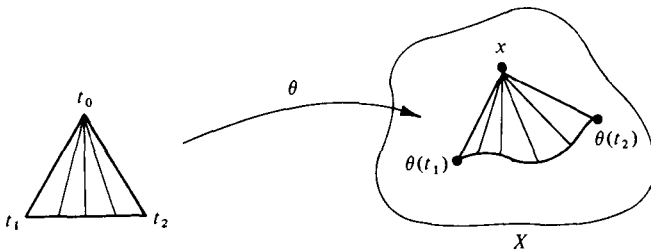

Figure 1.3

Now

$$\begin{aligned} & \lim_{t_0 \rightarrow 1} \|\theta(t_0, \dots, t_{p+1}) - x\| \\ &= \lim_{t_0 \rightarrow 1} \left\| (1 - t_0) \left(\phi \left(\frac{t_1}{1 - t_0}, \dots, \frac{t_{p+1}}{1 - t_0} \right) \right) - (1 - t_0)x \right\| \\ &\leq \lim_{t_0 \rightarrow 1} (1 - t_0) \left(\left\| \phi \left(\frac{t_1}{1 - t_0}, \dots, \frac{t_{p+1}}{1 - t_0} \right) \right\| + \|x\| \right). \end{aligned}$$

Since $\phi(\sigma_p)$ is compact, $(\|\phi(t_1/(1 - t_0), \dots, t_{p+1}/(1 - t_0))\| + \|x\|)$ is bounded. Thus, the final limit is zero because $\lim_{t_0 \rightarrow 1} (1 - t_0) = 0$, and it follows that θ is continuous.

It is evident from the construction that $\hat{\partial}_0(\theta) = \phi$. Since this procedure may be applied to any singular k -simplex, $k \geq 0$, there is a unique extension to a homomorphism

$$T: S_k(X) \rightarrow S_{k+1}(X)$$

such that $\hat{\partial}_0 \circ T = \text{identity}$. More generally we have for ϕ a singular k -simplex,

$$\begin{aligned} & \hat{\partial}_i(T(\phi))(t_0, \dots, t_k) \\ &= T(\phi)(t_0, \dots, t_{i-1}, 0, t_i, \dots, t_k) \\ &= (1 - t_0) \left(\phi \left(\frac{t_1}{1 - t_0}, \dots, \frac{t_{i-1}}{1 - t_0}, 0, \frac{t_i}{1 - t_0}, \dots, \frac{t_k}{1 - t_0} \right) \right) + t_0 x. \end{aligned}$$

On the other hand,

$$\begin{aligned} & T(\hat{\partial}_{i-1}(\phi))(t_0, \dots, t_k) \\ &= (1 - t_0) \left(\hat{\partial}_{i-1} \phi \left(\frac{t_1}{1 - t_0}, \dots, \frac{t_k}{1 - t_0} \right) + t_0 x \right) \\ &= (1 - t_0) \cdot \phi \left(\frac{t_1}{1 - t_0}, \dots, \frac{t_{i-1}}{1 - t_0}, 0, \frac{t_i}{1 - t_0}, \dots, \frac{t_k}{1 - t_0} \right) + t_0 x. \end{aligned}$$

Thus, for $1 \leq i \leq k + 1$,

$$\hat{\partial}_i T\phi = T(\hat{\partial}_{i-1}\phi).$$

Now let ϕ be any singular k -simplex

$$\begin{aligned} \hat{\partial}T\phi &= \hat{\partial}_0 T\phi + \sum_{i=1}^{k+1} (-1)^i \hat{\partial}_i T(\phi) \\ &= \hat{\partial}_0 T\phi + \sum_{i=1}^{k+1} (-1)^i \hat{\partial}_i T(\phi) - \left[\sum_{i=1}^{k+1} (-1)^i T\hat{\partial}_{i-1}(\phi) + \sum_{j=0}^k (-1)^j T\hat{\partial}_j\phi \right] \\ &= \phi - T\hat{\partial}\phi. \end{aligned}$$

So we have constructed a homomorphism $T: S_k(X) \rightarrow S_{k+1}(X)$ with the property that $\partial T + T\partial$ is the identity homomorphism on $S_k(X)$, whenever $k \geq 1$.

Now let z be an element of $Z_p(X)$. From the above, for $p > 0$, $(\partial T + T\partial)z = z$. Now since z is a cycle, $T\partial z = 0$. Thus, $z = \partial(Tz)$ and z is in $B_p(X)$. This implies that $H_p(X) = 0$ for all $p > 0$. \square

The construction used in proving Theorem 1.8 is a special case of a *chain homotopy* between chain complexes. Suppose $C = \{C_i, \partial\}$ and $C' = \{C'_i, \partial'\}$ are chain complexes and

$$T: C \rightarrow C'$$

is a homomorphism of graded groups of degree one (but not necessarily a chain map). Then consider the homomorphism

$$\partial' T + T\partial: C \rightarrow C'$$

of degree zero. This will be a chain map because

$$\partial'(\partial' T + T\partial) = \partial' \partial' T + \partial' T\partial = \partial' T\partial = \partial' T\partial + T\partial\partial = (\partial' T + T\partial)\partial.$$

This chain map $(\partial' T + T\partial)$ induces a homomorphism on homology

$$(\partial' T + T\partial)_*: H_p(C) \rightarrow H_p(C') \quad \text{for each } p.$$

Now if $z \in Z_p(C)$,

$$(\partial' T + T\partial)(z) = \partial' T(z)$$

which is in $B_p(C')$. Thus, $(\partial' T + T\partial)_*$ is the zero homomorphism for each p .

Given chain maps f and $g: C \rightarrow C'$, f and g are *chain homotopic* if there exists a homomorphism $T: C \rightarrow C'$ of degree one with $\partial' T + T\partial = f - g$.

1.9 Proposition. *If f and $g: C \rightarrow C'$ are chain homotopic chain maps, then $f_* = g_*$ as homomorphisms from $H_*(C)$ to $H_*(C')$.*

Proof. This follows immediately since if $T: C \rightarrow C'$ is a chain homotopy between f and g , then

$$0 = (\partial' T + T\partial)_* = (f - g)_* = f_* - g_*. \quad \square$$

As a special case, suppose that f and $g: X \rightarrow Y$ are maps for which the induced chain maps

$$f_\# \text{ and } g_\#: S_*(X) \rightarrow S_*(Y)$$

are chain homotopic. If T is a chain homotopy between $f_\#$ and $g_\#$, then T may be interpreted geometrically in the following way.

Let ϕ be a singular n -simplex in X . Then $T(\phi)$ may be viewed as a continuous deformation of $f_\#(\phi)$ into $g_\#(\phi)$. From Figure 1.4, $T(\phi)$ appears as a prism with ends $f_\#(\phi)$ and $g_\#(\phi)$ and sides $T(\partial\phi)$. Thus, it is reasonable that

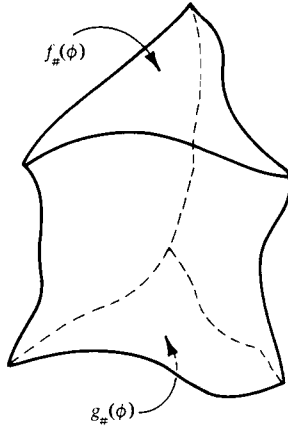

Figure 1.4

$$\partial T(\phi) = f_{\#}(\phi) - g_{\#}(\phi) - T(\partial\phi),$$

which is the algebraic requirement for T to be a chain homotopy.

If the chain $c = \sum m_i \phi_i$ is an n -cycle in X , then $f_{\#}(c)$ and $g_{\#}(c)$ are n -cycles in Y . $T(c)$ is a collection of integral multiples of such prisms and the algebraic sum of the sides must be zero since $\partial c = 0$. Thus, the boundary of $T(c)$ is the algebraic sum of the ends of the prisms, which is $f_{\#}(c) - g_{\#}(c)$, so that $f_{\#}(c)$ and $g_{\#}(c)$ are homologous cycles in Y .

Given spaces X and Y , two maps $f_0, f_1: X \rightarrow Y$ are *homotopic* if there exists a map

$$F: X \times I \rightarrow Y, \quad I = [0, 1],$$

with $F(x, 0) = f_0(x)$ and $F(x, 1) = f_1(x)$, for all x in X . The map F is a *homotopy* between f_0 and f_1 . Equivalently a homotopy is a family of maps $\{f_t\}_{0 \leq t \leq 1}$ from X to Y varying continuously with t . It is evident that the homotopy relation is an equivalence relation on the set of all maps from X to Y . It is customary to denote by $[X, Y]$ the set of homotopy classes of maps.

1.10 Theorem. *If $f_0, f_1: X \rightarrow Y$ are homotopic maps, then $f_{0\#} = f_{1\#}$ as homomorphisms from $H_*(X)$ to $H_*(Y)$.*

Proof. The idea of the proof is quite simple: if z is a cycle in X , then the images of z under f_0 and f_1 will be cycles in Y . Since f_0 may be continuously deformed into f_1 , the image of z under f_0 should admit a similar continuous deformation into the image of z under f_1 . This should imply that the two images are homologous cycles. We now proceed to put these geometric ideas into the current algebraic framework.

In view of Proposition 1.9 it will be sufficient to show that the chain maps

$f_{0\#}, f_{1\#}: S_*(X) \rightarrow S_*(Y)$ are chain homotopic. Let

$$F: X \times I \rightarrow Y$$

be a homotopy between f_0 and f_1 . Define maps

$$g_0, g_1: X \rightarrow X \times I$$

by $g_0(x) = (x, 0)$ and $g_1(x) = (x, 1)$:

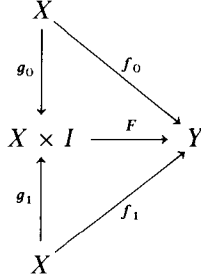

Then in the diagram each triangle is commutative, that is, $f_0 = F \circ g_0$ and $f_1 = F \circ g_1$.

Now suppose that $g_{0\#}$ and $g_{1\#}$ are chain homotopic as chain maps from $S_*(X)$ to $S_*(X \times I)$. This would mean that there exists a homomorphism

$$T: S_*(X) \rightarrow S_*(X \times I)$$

of degree one with $\partial T + T\partial = g_{0\#} - g_{1\#}$. Applying $F_{\#}$ to both sides gives

$$F_{\#}(\partial T + T\partial) = F_{\#}(g_{0\#} - g_{1\#}) \quad \text{or} \quad \partial(F_{\#}T) + (F_{\#}T)\partial = f_{0\#} - f_{1\#}.$$

Then $F_{\#}T$ is a homomorphism from $S_*(X)$ to $S_*(Y)$ of degree one and is a chain homotopy between $f_{0\#}$ and $f_{1\#}$. Therefore, it is sufficient to show that $g_{0\#}$ and $g_{1\#}$ are chain homotopic.

For σ_n the standard n -simplex denote by $\tau_n \in S_n(\sigma_n)$ the element represented by the identity map. Note that if $\phi: \sigma_n \rightarrow X$ is any singular n -simplex in X , then the induced homomorphism

$$\phi_{\#}: S_n(\sigma_n) \rightarrow S_n(X)$$

has $\phi_{\#}(\tau_n) = \phi$. It is evident that every singular n -simplex in X can be exhibited as the image of τ_n in this manner. Our technique of proof then will be to first give a construction involving τ_n and then extend it to all of $S_n(X)$ by the above approach.

We construct a chain homotopy T between $g_{0\#}$ and $g_{1\#}$ inductively on the dimension of the chain group. To do the inductive step first, suppose that $n > 0$ and for all spaces X and integers $i < n$ there is a homomorphism

$$T: S_i(X) \rightarrow S_{i+1}(X \times I)$$

such that $\partial T + T\partial = g_{0\#} - g_{1\#}$. Assume further that this is natural in the sense that given any map $h: X \rightarrow W$ of spaces, commutativity holds in the

diagram

$$\begin{array}{ccc} S_i(X) & \xrightarrow{T_X} & S_{i+1}(X \times I) \\ \downarrow h_{\#} & & \downarrow (h \times \text{id})_{\#} \\ S_i(W) & \xrightarrow{T_W} & S_{i+1}(W \times I) \end{array}$$

for all $i < n$.

To define T on the n -chains of X , it is sufficient to define T on the singular n -simplices. So let $\phi: \sigma_n \rightarrow X$ be a singular n -simplex and recall that $\phi_{\#}(\tau_n) = \phi$. Thus, by defining $T_{\sigma_n}: S_n(\sigma_n) \rightarrow S_{n+1}(\sigma_n \times I)$, the naturality of the construction will require that

$$T_X(\phi) = T_X(\phi_{\#}(\tau_n)) = (\phi \times \text{id})_{\#}(T_{\sigma_n}(\tau_n)).$$

So to define T_X it is sufficient to define T_{σ_n} on $S_n(\sigma_n)$.

Let d be a singular n -simplex in σ_n and consider the chain in $S_n(\sigma_n \times I)$ given by

$$c = g_{0\#}(d) - g_{1\#}(d) - T_{\sigma_n}(\partial d),$$

which is defined by the induction hypothesis since ∂d is in $S_{n-1}(\sigma_n)$. Note that from the preceding discussion, c corresponds to the boundary of a certain prism in σ_n . Then

$$\begin{aligned} \partial c &= \partial g_{0\#}(d) - \partial g_{1\#}(d) - \partial T_{\sigma_n}(\partial d) \\ &= g_{0\#}(\partial d) - g_{1\#}(\partial d) - [g_{0\#}(\partial d) - g_{1\#}(\partial d) - T_{\sigma_n} \partial(\partial d)] \\ &= 0. \end{aligned}$$

Thus, c is a cycle of dimension n in the convex set $\sigma_n \times I$. From Theorem 1.8 it follows that c is also a boundary. So let $b \in S_{n+1}(\sigma_n \times I)$ with $\partial b = c$. Geometrically b is the solid prism of which c is the boundary. Then define

$$T_{\sigma_n}(d) = b$$

and observe that

$$\partial T(d) + T\partial(d) = g_{0\#}(d) - g_{1\#}(d).$$

Now for any singular n -simplex $\phi: \sigma_n \rightarrow X$ define, as before,

$$T_X(\phi) = (\phi \times \text{id})_{\#} T_{\sigma_n}(\tau_n).$$

So defined on the generators there is a unique extension to a homomorphism

$$T_X: S_n(X) \rightarrow S_{n+1}(X \times I).$$

This inductive construction indicates the proper definition for T on 0-chains. Recall that σ_0 is a point and consider the chain c in $S_0(\sigma_0 \times I)$ given by

$$c = g_{0\#}(\tau_0) - g_{1\#}(\tau_0).$$

Take a singular 1-simplex b in $\sigma_0 \times I$ with boundary $g_{0\#}(\tau_0) - g_{1\#}(\tau_0)$ and define $T_{\sigma_0}(\tau_0) = b$. This defines T on 0-chains by the same technique.

Finally it must be noted that in the definition given for T_X on n -chains of X ,

$$\partial T_X + T_X \partial = g_{0\#} - g_{1\#}$$

and that the construction is suitably natural with respect to maps $h: X \rightarrow W$. Note that if ϕ is a singular n -simplex in X ,

$$g_{0\#}(\phi) = g_{0\#} \phi_{\#}(\tau_n) = (\phi \times \text{id})_{\#} g_{0\#}(\tau_n)$$

and similarly

$$g_{1\#}(\phi) = g_{1\#} \phi_{\#}(\tau_n) = (\phi \times \text{id})_{\#} g_{1\#}(\tau_n).$$

Now consider

$$\begin{aligned} \partial T(\phi) + T\partial(\phi) &= \partial T\phi_{\#}(\tau_n) + T\partial\phi_{\#}(\tau_n) \\ &= \partial(\phi \times \text{id})_{\#} T(\tau_n) + T\phi_{\#} \partial(\tau_n) \\ &= (\phi \times \text{id})_{\#} \partial T(\tau_n) + (\phi \times \text{id})_{\#} T\partial(\tau_n) \\ &= (\phi \times \text{id})_{\#} (g_{0\#}(\tau_n) - g_{1\#}(\tau_n)) \\ &= g_{0\#}(\phi) - g_{1\#}(\phi). \end{aligned}$$

The naturality follows similarly.

Therefore, T_X gives a chain homotopy between $g_{0\#}$ and $g_{1\#}$, and we have completed the proof that $f_{0\#} = f_{1\#}$. \square

Note that this generalizes the approach in Theorem 1.8. There we used the fact that, since X was convex, the identity map was homotopic to the map sending all of X into the point x . Thus in positive dimensions the identity homomorphism and the trivial homomorphism agree, and the positive dimensional homology of X is trivial.

Let $f: X \rightarrow Y$ and $g: Y \rightarrow X$ be maps of topological spaces. If the compositions $f \circ g$ and $g \circ f$ are each homotopic to the respective identity map, then f and g are *homotopy inverses* of each other. A map $f: X \rightarrow Y$ is a *homotopy equivalence* if f has a homotopy inverse; in this case X and Y are said to have the *same homotopy type*.

1.11 Proposition. *If $f: X \rightarrow Y$ is a homotopy equivalence, then $f_{\#}: H_n(X) \rightarrow H_n(Y)$ is an isomorphism for each n .*

Proof. If g is a homotopy inverse for f , then by Theorem 1.10 $f_{\#} \circ g_{\#} = (f \circ g)_{\#} = \text{identity}$ and $g_{\#} \circ f_{\#} = (g \circ f)_{\#} = \text{identity}$ so that $g_{\#} = f_{\#}^{-1}$ and $f_{\#}$ is an isomorphism. \square

Suppose that $i: A \rightarrow X$ is the inclusion map of a subspace A of X . A map $g: X \rightarrow A$ such that $g \circ i$ is the identity on A is a *retraction* of X onto A . If

furthermore the composition $i \circ g: X \rightarrow X$ is homotopic to the identity, then g is a *deformation retraction* and A is a *deformation retract* of X . Note that in this case the inclusion i is a homotopy equivalence.

1.12 Corollary. *If $i: A \rightarrow X$ is the inclusion of a retract A of X , then $i_*: H_*(A) \rightarrow H_*(X)$ is a monomorphism onto a direct summand. If A is a deformation retract of X , then i_* is an isomorphism.*

Proof. The second statement follows immediately from Proposition 1.11. To prove the first, let $g: X \rightarrow A$ be a retraction. Then

$$g_* \circ i_* = (g \circ i)_* = (\text{id})_* = \text{identity on } H_*(A).$$

Hence, i_* is a monomorphism.

Define subgroups of $H_*(X)$ by $G_1 = \text{image } i_*$ and $G_2 = \text{kernel } g_*$. Let $\alpha \in G_1 \cap G_2$, so that $\alpha = i_*(\beta)$ for some $\beta \in H_*(A)$ and $g_*(\alpha) = 0$. However

$$0 = g_*(\alpha) = g_* i_*(\beta) = \beta$$

so that $\alpha = i_*(\beta)$ must be zero. On the other hand, let $\gamma \in H_*(X)$. Then

$$\gamma = i_* g_*(\gamma) + (\gamma - i_* g_*(\gamma))$$

expresses γ as the sum of an element in G_1 and an element in G_2 . Therefore, $H_*(X) \approx G_1 \oplus G_2$ and the proof is complete. \square

A triple $C \xrightarrow{f} D \xrightarrow{g} E$ of abelian groups and homomorphisms is *exact* if $\text{image } f = \text{kernel } g$. A sequence of abelian groups and homomorphisms

$$\cdots \longrightarrow G_1 \xrightarrow{f_1} G_2 \xrightarrow{f_2} G_3 \xrightarrow{f_3} \cdots \xrightarrow{f_{n-1}} G_n \xrightarrow{f_n} \cdots$$

is exact if each triple is exact. An exact sequence

$$0 \rightarrow C \xrightarrow{f} D \xrightarrow{g} E \rightarrow 0$$

is called *short exact*. This is a generalization of the concept of isomorphism in the sense that $h: G_1 \rightarrow G_2$ is an isomorphism if and only if

$$0 \rightarrow G_1 \xrightarrow{h} G_2 \rightarrow 0$$

is exact.

Note that in a short exact sequence as above, f is a monomorphism and identifies C with a subgroup $C' \subseteq D$. Also g is an epimorphism with kernel C' . Thus up to isomorphism the sequence is just

$$0 \rightarrow C' \xrightarrow{i} D \xrightarrow{\pi} D/C' \rightarrow 0.$$

Suppose now that $C = \{C_n\}$, $D = \{D_n\}$ and $E = \{E_n\}$ are chain complexes and

$$0 \rightarrow C \xrightarrow{f} D \xrightarrow{g} E \rightarrow 0$$

is a short exact sequence where f and g are chain maps of degree zero. Hence,

for each p there is an associated triple of homology groups,

$$H_p(C) \xrightarrow{f_*} H_p(D) \xrightarrow{g_*} H_p(E).$$

We now want to examine precisely how this deviates from being short exact.

So we are assuming that we have an infinite diagram in which the rows are short exact sequences and each square is commutative.

$$\begin{array}{ccccccc}
 & \vdots & & \vdots & & \vdots & \\
 & \downarrow & & \downarrow & & \downarrow & \\
 0 & \longrightarrow & C_n & \xrightarrow{f} & D_n & \xrightarrow{g} & E_n \longrightarrow 0 \\
 & & \downarrow \partial & & \downarrow \partial & & \downarrow \partial \\
 0 & \longrightarrow & C_{n-1} & \xrightarrow{f} & D_{n-1} & \xrightarrow{g} & E_{n-1} \longrightarrow 0 \\
 & & \downarrow \partial & & \downarrow \partial & & \downarrow \partial \\
 & & \vdots & & \vdots & & \vdots
 \end{array}$$

Let $z \in Z_n(E)$, that is, $z \in E_n$ and $\partial z = 0$. Since g is an epimorphism, there exists an element $d \in D_n$ with $g(d) = z$. From the fact that g is a chain map we have

$$g(\partial d) = \partial(g(d)) = \partial z = 0.$$

The exactness implies that ∂d is in the image of f , so let $c \in C_{n-1}$ with $f(c) = \partial d$. Note that

$$f(\partial c) = \partial f(c) = \partial(\partial d) = 0,$$

and since f is a monomorphism, ∂c must be zero, and $c \in Z_{n-1}(C)$.

The correspondence $z \rightarrow c$ of $Z_n(E)$ into $Z_{n-1}(C)$ is not a well-defined function from cycles to cycles due to the number of possible choices in the construction. However, we now show that the associated correspondence on the homology groups is a well-defined homomorphism.

Let $z, z' \in Z_n(E)$ be homologous cycles. So there exists an element $e \in E_{n+1}$ with $\partial(e) = z - z'$. Let $d, d' \in D_n$ with $g(d) = z$, $g(d') = z'$, and $c, c' \in C_{n-1}$ with $f(c) = \partial d$, $f(c') = \partial d'$. We must show that c and c' are homologous cycles.

There exists an element $a \in D_{n+1}$ with $g(a) = e$. By the commutativity

$$g(\partial a) = \partial g(a) = \partial e = z - z',$$

so we observe that $(d - d') - \partial a$ is in the kernel of g , hence also in the image of f . Let $b \in C_n$ with $f(b) = (d - d') - \partial a$. Now we have

$$\begin{aligned}
 f(\partial b) &= \partial f(b) = \partial(d - d' - \partial a) = \partial d - \partial d' \\
 &= f(c) - f(c') = f(c - c').
 \end{aligned}$$

Since f is one to one, it follows that $c - c' = \partial b$ and c and c' are homologous cycles. Therefore, the correspondence induced on the homology groups is well defined and obviously must be a homomorphism.

This homomorphism is denoted by $\Delta: H_n(E) \rightarrow H_{n-1}(C)$ and called the *connecting homomorphism* for the short exact sequence

$$0 \rightarrow C \xrightarrow{f} D \xrightarrow{g} E \rightarrow 0.$$

1.13 Theorem. *If $0 \rightarrow C \xrightarrow{f} D \xrightarrow{g} E \rightarrow 0$ is a short exact sequence of chain complexes and degree zero chain maps, then the long exact sequence*

$$\cdots \xrightarrow{f_*} H_n(D) \xrightarrow{g_*} H_n(E) \xrightarrow{\Delta} H_{n-1}(C) \xrightarrow{f_*} H_{n-1}(D) \xrightarrow{g_*} \cdots$$

is exact.

EXERCISE 4. Prove Theorem 1.13. □

It is important to note that the construction of the connecting homomorphism is suitably natural. That is, if

$$\begin{array}{ccccccccc} 0 & \longrightarrow & C & \xrightarrow{f} & D & \xrightarrow{g} & E & \longrightarrow & 0 \\ & & \downarrow \alpha & & \downarrow \beta & & \downarrow \gamma & & \\ 0 & \longrightarrow & C' & \xrightarrow{f'} & D' & \xrightarrow{g'} & E' & \longrightarrow & 0 \end{array}$$

is a diagram of chain complexes and degree zero chain maps in which the rows are exact and the rectangles are commutative, then commutativity holds in each rectangle of the associated diagram

$$\begin{array}{ccccccccc} \cdots & \longrightarrow & H_n(D) & \xrightarrow{g_*} & H_n(E) & \xrightarrow{\Delta} & H_{n-1}(C) & \xrightarrow{f_*} & H_{n-1}(D) & \longrightarrow & \cdots \\ & & \downarrow \beta_* & & \downarrow \gamma_* & & \downarrow \alpha_* & & \downarrow \beta_* & & \\ \cdots & \longrightarrow & H_n(D') & \xrightarrow{g'_*} & H_n(E') & \xrightarrow{\Delta'} & H_{n-1}(C') & \xrightarrow{f'_*} & H_{n-1}(D') & \longrightarrow & \cdots \end{array}$$

Let X be a topological space and $A \subseteq X$ a subspace. The *interior* of A ($\text{Int } A$) is the union of all open subsets of X which are contained in A , or equivalently the maximal subset of A which is open in X . A collection \mathcal{U} of subsets of X is a covering of X if $X \subseteq \bigcup_{U \in \mathcal{U}} U$. Given a collection \mathcal{U} , let $\text{int } \mathcal{U}$ be the collection of interiors of elements of \mathcal{U} . We will be interested in those \mathcal{U} for which $\text{int } \mathcal{U}$ is a covering of X .

For \mathcal{U} any covering of X , denote by $S_n^{\mathcal{U}}(X)$ the subgroup of $S_n(X)$ generated by the singular n -simplices $\phi: \sigma_n \rightarrow X$ for which $\phi(\sigma_n)$ is contained in some $U \in \mathcal{U}$. Then for each i

$$\text{image } \partial_i \phi \subseteq \text{image } \phi$$

so that the total boundary

$$\partial: S_n^{\mathcal{U}}(X) \rightarrow S_{n-1}^{\mathcal{U}}(X).$$

So associated with any covering \mathcal{U} of X there is a chain complex $S_*^{\mathcal{U}}(X)$ and the natural inclusion

$$i: S_*^{\mathcal{U}}(X) \rightarrow S_*(X)$$

is a chain map. Note that if \mathcal{V} is a covering of a space Y and $f: X \rightarrow Y$ is a map such that for each $U \in \mathcal{U}$, $f(U)$ is contained in some V of \mathcal{V} , then there is a chain map

$$f_{\#}: S_*^{\mathcal{U}}(X) \rightarrow S_*^{\mathcal{V}}(Y)$$

and $f_{\#} \circ i_X = i_Y \circ f_{\#}$.

We are now ready for the theorem which will serve as the essential computational tool in studying the homology groups of spaces.

1.14 Theorem. *If \mathcal{U} is a family of subsets of X such that $\text{Int } \mathcal{U}$ is a covering of X , then*

$$i_{\#}: H_n(S_*^{\mathcal{U}}(X)) \rightarrow H_n(X)$$

is an isomorphism for each n .

Proof. See Appendix I. □

The proof is deferred to an appendix to avoid a lengthy interruption of the exposition. It should not be assumed that this implies the proof is either irrelevant or uninteresting. Indeed this argument characterizes the basic difference between homology theory and homotopy theory. Intuitively the approach to proving this theorem is evident. Given a chain c in X we must construct a chain c' in X such that c' is in the image of i and $\partial c = \partial c'$. Moreover, if c is a cycle we will want c' to be homologous to c . This is done by “subdividing” the chain c repeatedly until the resulting chain is the desired c' . The technique of subdivision is possible in homology theory because an n -simplex may be subdivided into a collection of smaller n -simplices. However, the subdivision of a sphere does not result in a collection of smaller spheres. It is the absence of such a construction, that makes the computation of homotopy groups extremely difficult for spaces as simple as a sphere.

To see the requirement that $\text{Int } \mathcal{U}$ covers X is essential, let $X = S^1$, $x_0 \in S^1$, and $\mathcal{U} = \{\{x_0\}, S^1 - \{x_0\}\}$. Then any chain c in $S_1^{\mathcal{U}}(S^1)$ may be uniquely written as the sum of a chain c_1 in $\{x_0\}$ and a chain c_2 in $S^1 - \{x_0\}$. Moreover, since the image of c_2 is contained in a compact subset of $S^1 - \{x_0\}$, c will be a cycle if and only if each of c_1 and c_2 are cycles. Now both c_1 and c_2 must then also be boundaries; hence, $H_1(S_*^{\mathcal{U}}(S^1)) = 0$. However, it will soon be shown that $H_1(S^1) \approx \mathbb{Z}$.

The first application of Theorem 1.14 will be the development of a technique for studying the homology of a space X in terms of the homology of the components of a covering \mathcal{U} of X . In the simplest nontrivial case the covering \mathcal{U} consists of two subsets U and V for which $\text{Int } U \cup \text{Int } V = X$. For

convenience let A' be the set of all singular n -simplices in U and A'' be the set of all singular n -simplices in V . Then

$$\begin{aligned} S_n(U) &= F(A'), & S_n(V) &= F(A''), \\ S_n(U \cap V) &= F(A' \cap A''), & S_n^{\#}(X) &= F(A' \cup A''). \end{aligned}$$

Note that there is a natural homomorphism

$$h: F(A') \oplus F(A'') \rightarrow F(A' \cup A'')$$

given by

$$h(a'_i, a''_j) = a'_i + a''_j.$$

It is not difficult to see that h is an epimorphism. On the other hand, there is the homomorphism

$$g: F(A' \cap A'') \rightarrow F(A') \oplus F(A'')$$

given by

$$g(b_i) = (b_i, -b_i).$$

It follows immediately that g is a monomorphism and $h \circ g = 0$. Now suppose

$$h(\sum n_i a'_i, \sum m_j a''_j) = 0.$$

That is

$$\sum n_i a'_i + \sum m_j a''_j = 0.$$

Since these are free abelian groups, the only way this can happen is for each nonzero n_i , $a'_i = a''_j$ for some j and furthermore $m_j = -n_i$. All nonzero coefficients m_j must appear in this manner. This implies that all a'_i are in $A' \cap A''$ and if $x = \sum n_i a'_i$, then $\sum m_j a''_j = -x$. Hence,

$$x \in F(A' \cap A'') \quad \text{and} \quad g(x) = (\sum n_i a'_i, \sum m_j a''_j).$$

This proves that the kernel of h is contained in the image of g , and interpreting these facts in terms of the chain groups gives for each n a short exact sequence

$$0 \rightarrow S_n(U \cap V) \xrightarrow{g_*} S_n(U) \oplus S_n(V) \xrightarrow{h_*} S_n^{\#}(X) \rightarrow 0.$$

Define a chain complex $S_*(U) \oplus S_*(V)$ by setting $(S_*(U) \oplus S_*(V))_n = S_n(U) \oplus S_n(V)$ and letting the boundary operator be the usual boundary on each component. Then the above sequence becomes a short exact sequence of chain complexes and degree zero chain maps.

By Theorem 1.13 there is associated a long exact sequence of homology groups,

$$\cdots \xrightarrow{\Delta} H_n(U \cap V) \xrightarrow{g_*} H_n(S_*(U) \oplus S_*(V)) \xrightarrow{h_*} H_n(S_*^{\#}(X)) \xrightarrow{\Delta} H_{n-1}(U \cap V) \rightarrow \cdots.$$

From the definition of the chain complex it is evident that $H_n(S_*(U) \oplus$

$S_*(V) \approx H_n(U) \oplus H_n(V)$, and by Theorem 1.14 we have $H_n(S_*^{\mathcal{U}}(X)) \approx H_n(X)$. Incorporating these isomorphisms into the long exact sequence, we have established the *Mayer–Vietoris sequence*

$$\cdots \xrightarrow{\Delta} H_n(U \cap V) \xrightarrow{g_*} H_n(U) \oplus H_n(V) \xrightarrow{h_*} H_n(X) \xrightarrow{\Delta} H_{n-1}(U \cap V) \rightarrow \cdots.$$

Note that if we define by

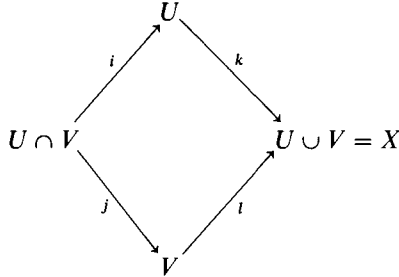

the respective inclusion maps, then $g_*(x) = (i_*(x), -j_*(x))$ and $h_*(y, z) = k_*(y) + l_*(z)$. The connecting homomorphism Δ may be interpreted geometrically as follows: any homology class ω in $H_n(X)$ may be represented by a cycle $c + d$ where c is a chain in U and d is a chain in V . (This follows from Theorem 1.14.) Then $\Delta(\omega)$ is represented by the cycle ∂c in $U \cap V$.

The construction of the Mayer–Vietoris sequence is natural in the sense that if X' is a space, U' and V' are subsets with $\text{Int } U' \cup \text{Int } V' = X'$, and $f: X \rightarrow X'$ is a map for which $f(U) \subseteq U'$ and $f(V) \subseteq V'$, then commutativity holds in each rectangle of the diagram

$$\begin{array}{ccccccc} \cdots \xrightarrow{\Delta} H_n(U \cap V) & \xrightarrow{g_*} & H_n(U) \oplus H_n(V) & \xrightarrow{h_*} & H_n(X) & \xrightarrow{\Delta} & H_{n-1}(U \cap V) \rightarrow \cdots \\ & \downarrow f_* & \downarrow f_* \oplus f_* & & \downarrow f_* & & \downarrow f_* \\ \cdots \xrightarrow{\Delta'} H_n(U' \cap V') & \xrightarrow{g'_*} & H_n(U') \oplus H_n(V') & \xrightarrow{h'_*} & H_n(X') & \xrightarrow{\Delta'} & H_{n-1}(U' \cap V') \rightarrow \cdots \end{array}$$

EXAMPLE. Let $X = S^1$ and denote by z and z' the north and south poles, respectively, and by x and y the points on the equator (Figure 1.5). Let $U = S^1 - \{z'\}$ and $V = S^1 - \{z\}$. Then in the Mayer–Vietoris sequence associated with this covering we have

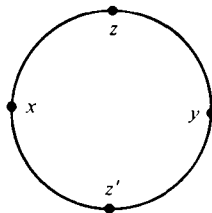

Figure 1.5

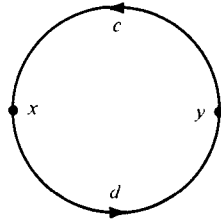

Figure 1.6

$$H_1(U) \oplus H_1(V) \xrightarrow{h_*} H_1(S^1) \xrightarrow{\Delta} H_0(U \cap V) \xrightarrow{g_*} H_0(U) \oplus H_0(V).$$

The first term is zero since U and V are contractible. Thus, Δ is a monomorphism and $H_1(S^1)$ will be isomorphic to the image of $\Delta =$ the kernel of g_* . An element of $H_0(U \cap V) \approx Z \oplus Z$ may be written in the form $ax + by$, where a and b are integers.

Now

$$g_*(ax + by) = (i_*(ax + by), -j_*(ax + by)).$$

Since U and V are pathwise connected, $i_*(ax + by) = 0$ if and only if $a = -b$ and similarly for j_* . Thus the kernel of g_* is the subgroup of $H_0(U \cap V)$ consisting of all elements of the form $ax - ay$. This is an infinite cyclic subgroup generated by $x - y$. Therefore, we conclude that

$$H_1(S^1) \approx Z.$$

To give geometrically a generator ω for this group, we must represent ω by the sum of two chains, $c + d$, where c is in U and d is in V , for which $\partial(c) = x - y = -\partial d$. The chains c and d may be chosen as shown in Figure 1.6.

For any integer $n > 1$ the portion of the Mayer-Vietoris sequence

$$H_n(U) \oplus H_n(V) \xrightarrow{h_*} H_n(S^1) \xrightarrow{\Delta} H_{n-1}(U \cap V)$$

has the two end terms equal to zero; hence, $H_n(S^1) = 0$.

This completes the determination of the homology of S^1 . We now proceed inductively to compute the homology of S^n for each n . Recall that

$$S^n = \{(x_1, \dots, x_{n+1}) \mid x_i \in \mathbb{R}, \sum x_i^2 = 1\} \subseteq \mathbb{R}^{n+1}.$$

In the usual fashion consider $\mathbb{R}^n \subseteq \mathbb{R}^{n+1}$ as all points of the form $(x_1, \dots, x_n, 0)$. Under this inclusion $S^{n-1} \subseteq S^n$ as the “equator.” Denote by $z = (0, \dots, 0, 1)$ and $z^1 = (0, \dots, 0, -1)$ the north and south poles of S^n . Then by stereographic projection $S^n - \{z\}$ is homeomorphic to \mathbb{R}^n , and similarly for $S^n - \{z^1\}$. Furthermore, $S^n - \{z \cup z^1\}$ is homeomorphic to $\mathbb{R}^n - \{\text{origin}\}$.

EXERCISE 5. Show that S^{n-1} is a deformation retract of $\mathbb{R}^n - \{\text{origin}\}$.

Now let $U = S^n - \{z\}$, $V = S^n - \{z^1\}$ so that $U \cap V = S^n - \{z \cup z^1\}$. Then by the observations and the exercise above, the Mayer-Vietoris sequence for

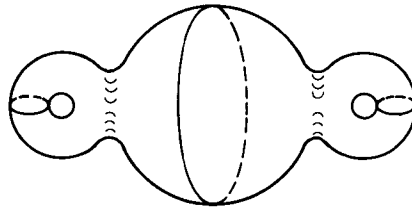

Figure 1.7

this covering becomes

$$H_m(\mathbb{R}^n) \oplus H_m(\mathbb{R}^n) \xrightarrow{h_*} H_m(S^n) \xrightarrow{\Delta} H_{m-1}(S^{n-1}) \xrightarrow{g_*} H_{m-1}(\mathbb{R}^n) \oplus H_{m-1}(\mathbb{R}^n).$$

For $m > 1$, the end terms are zero so that Δ is an isomorphism. For $m = 1$ and $n > 1$, g_* and Δ must both be monomorphisms so that $H_1(S^n) = 0$. This furnishes the inductive step in the proof of the following:

1.15 Theorem. *For any integer $n \geq 0$, $H_*(S^n)$ is a free abelian group with two generators, one in dimension zero and one in dimension n .* □

1.16 Corollary. *For $n \neq m$, S^n and S^m do not have the same homotopy type.* □

EXERCISE 6. Using only the tools that we have developed, compute the homology of a two-sphere with two handles (Figure 1.7).

Define the n -disk in \mathbb{R}^n to be

$$D^n = \{(x_1, \dots, x_n) \in \mathbb{R}^n \mid \sum x_i^2 \leq 1\}$$

and note that $S^{n-1} \subseteq D^n$ is its boundary.

1.17 Corollary. *There is no retraction of D^n onto S^{n-1} .*

Proof. For $n = 1$ this is obvious since D^1 is connected and S^0 is not. Suppose $n > 1$ and $f: D^n \rightarrow S^{n-1}$ is a map such that $f \circ i = \text{identity}$, where i is the inclusion of S^{n-1} in D^n .

This implies that the following diagram of homology groups and induced homomorphisms is commutative:

$$\begin{array}{ccc} H_{n-1}(S^{n-1}) & \xrightarrow{\text{id}} & H_{n-1}(S^{n-1}) \\ & \searrow i_* & \nearrow f_* \\ & & H_{n-1}(D^n) \end{array}$$

However, this gives a factorization of the identity on an infinite cyclic group through zero which is impossible. Therefore, no such retraction f exists. □

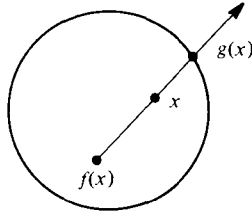

Figure 1.8

1.18 Corollary (Brouwer fixed-point theorem). *Given a map $f: D^n \rightarrow D^n$, there exists an x in D^n with $f(x) = x$.*

Proof. Suppose $f: D^n \rightarrow D^n$ without fixed points. Define a function $g: D^n \rightarrow S^{n-1}$ as follows: for $x \in D^n$ there is a well-defined ray starting at $f(x)$ and passing through x . Define $g(x)$ to be the point at which this ray intersects S^{n-1} (Figure 1.8). Then $g: D^n \rightarrow S^{n-1}$ is continuous and $g(x) = x$ for all x in S^{n-1} . But the existence of such a map g contradicts Corollary 1.17. Therefore, f must have a fixed point. \square

EXERCISE 7. Show that Corollary 1.18 implies Corollary 1.17.

Let $n \geq 1$ and suppose that $f: S^n \rightarrow S^n$ is a map. Choose a generator α of $H_n(S^n) \approx \mathbb{Z}$ and note that the homomorphism induced by f on $H_n(S^n)$ has $f_*(\alpha) = m \cdot \alpha$ for some integer m . This integer is independent of the choice of the generator since $f_*(-\alpha) = -f_*(\alpha) = -m \cdot \alpha = m \cdot (-\alpha)$. The integer m is the *degree* of f , denoted $d(f)$. This is often referred to as the *Brouwer degree* as a result of the work of L.E.J. Brouwer. The degree of a map is a direct generalization of the “winding number” associated with a map from the circle into the nonzero complex numbers.

The following basic properties of the degree of a map are immediate consequences of our previous results:

- (a) $d(\text{identity}) = 1$;
- (b) if f and $g: S^n \rightarrow S^n$ are maps, $d(f \circ g) = d(f) \cdot d(g)$;
- (c) $d(\text{constant map}) = 0$;
- (d) if f and g are homotopic, then $d(f) = d(g)$;
- (e) if f is a homotopy equivalence then $d(f) = \pm 1$.

A slightly less obvious property (a future exercise) is that there exist maps of any integral degree on S^n whenever $n > 0$. All these properties are results of homology theory, and as such are easily obtained. A much more sophisticated property is the homotopy theoretic result of Hopf, which is the converse of property (d), if $d(f) = d(g)$ then f and g are homotopic. Thus, the degree is a complete algebraic invariant for studying homotopy classes of maps from S^n to S^n .

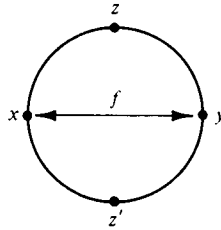

Figure 1.9

1.19 Proposition. Let $n > 0$ and define $f: S^n \rightarrow S^n$ by

$$f(x_1, x_2, \dots, x_{n+1}) = (-x_1, x_2, \dots, x_{n+1}).$$

Then $d(f) = -1$.

Proof. First consider the case $n = 1$ (Figure 1.9). As before let $z = (0, 1)$, $z^1 = (0, -1)$ and $x = (-1, 0)$, $y = (1, 0)$. The covering $U = S^1 - \{z^1\}$ and $V = S^1 - \{z\}$ has the property that $f(U) \subseteq U$ and $f(V) \subseteq V$.

Thus, by the naturality of the Mayer-Vietoris sequence the diagram

$$\begin{array}{ccccc} 0 & \longrightarrow & H_1(S^1) & \xrightarrow{\Delta} & H_0(U \cap V) \\ & & \downarrow f_* & & \downarrow f_{3*} \\ 0 & \longrightarrow & H_1(S^1) & \xrightarrow{\Delta} & H_0(U \cap V) \end{array}$$

has exact rows, and the rectangle commutes where f_3 is the restriction of f . Recall that a generator α of $H_1(S^1)$ was represented by the cycle $c + d$ where $\partial c = x - y = -\partial d$, and $\Delta(\alpha)$ is represented by $x - y$. Now

$$\Delta f_*(\alpha) = f_{3*} \Delta(\alpha) = f_{3*}(x - y) = y - x = -\Delta(\alpha) = \Delta(-\alpha).$$

Since Δ is a monomorphism, $d(f) = -1$.

Now suppose the conclusion is true in dimension $n - 1 \geq 1$ and consider $S^{n-1} \subseteq S^n$ as before. Taking U and V to be the complements of the south pole and the north pole, respectively, in S^n , the inclusion

$$i: S^{n-1} \rightarrow U \cap V$$

is a homotopy equivalence. Since $n \geq 2$, the connecting homomorphism in the Mayer-Vietoris sequence is an isomorphism. Thus, in the diagram

$$\begin{array}{ccccccc} H_n(S^n) & \xrightarrow[\cong]{\Delta} & H_{n-1}(U \cap V) & \xleftarrow[\cong]{i_*} & H_{n-1}(S^{n-1}) \\ \downarrow f_* & & \downarrow f_{3*} & & \downarrow f_* \\ H_n(S^n) & \xrightarrow[\cong]{\Delta} & H_{n-1}(U \cap V) & \xleftarrow[\cong]{i_*} & H_{n-1}(S^{n-1}) \end{array}$$

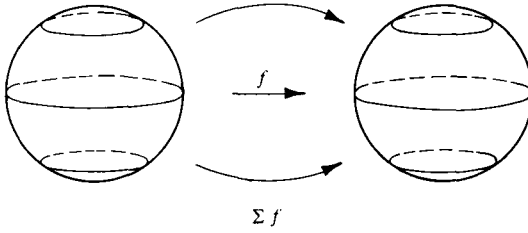

Figure 1.10

each rectangle commutes and the horizontal homomorphisms are isomorphisms. If α is a generator of $H_n(S^n)$,

$$f_*(\alpha) = \Delta^{-1}f_{3*}\Delta(\alpha) = \Delta^{-1}i_*f_*i_*^{-1}\Delta(\alpha) = -\Delta^{-1}i_*i_*^{-1}\Delta(\alpha) = -\alpha.$$

This gives the inductive step and the proof is complete. □

For a given map $f: S^n \rightarrow S^n$, $n \geq 0$, there is associated a map $g: S^{n+1} \rightarrow S^{n+1}$ called the *suspension* of f and denoted by Σf . Intuitively, the idea is that the restriction to the equator (S^n) in S^{n+1} should be f and each slice in S^{n+1} parallel to the equator should be mapped into the corresponding slice in the manner prescribed by f (Figure 1.10). Specifically consider $S^{n+1} \subseteq \mathbb{R}^{n+2} = \mathbb{R}^{n+1} \times \mathbb{R}^1$ so that the points of S^{n+1} are of the form (x, t) , where $x \in \mathbb{R}^{n+1}$, $t \in \mathbb{R}^1$ and $\|x\|^2 + |t|^2 = 1$. Then define

$$\Sigma f(x, t) = \begin{cases} (x, t) & \text{if } x = 0 \\ (\|x\| \cdot f(x/\|x\|), t) & \text{if } x \neq 0. \end{cases}$$

It is not difficult to see that Σf is continuous and has the desired characteristics.

The technique used in proving Proposition 1.19 may be applied to establish the following:

1.20 Proposition. *If $f: S^n \rightarrow S^n$, $n \geq 1$ is a map, then $d(\Sigma f) = d(f)$.* □

Note that if $f(x_1, \dots, x_{n+1}) = (-x_1, \dots, x_{n+1})$ and $g(x_1, \dots, x_{n+2}) = (-x_1, \dots, x_{n+2})$, then $g = \Sigma f$ and Proposition 1.19 is a special case of Proposition 1.20.

1.21 Corollary. *If $f: S^n \rightarrow S^n$ is given by*

$$f(x_1, \dots, x_{n+1}) = (x_1, \dots, -x_i, \dots, x_{n+1}),$$

then $d(f) = -1$.

Proof. Let $h: S^n \rightarrow S^n$ be the map that exchanges the first coordinate and the i th coordinate. Then h is a homeomorphism ($h^{-1} = h$), so $d(h) = \pm 1$. Let

$g(x_1, \dots, x_{n+1}) = (-x_1, \dots, x_{n+1})$ so that $d(g) = -1$. Then

$$d(f) = d(h \circ g \circ h) = d(h)^2 d(g) = (\pm 1)^2 (-1) = -1. \quad \square$$

1.22 Corollary. *The antipodal map $A: S^n \rightarrow S^n$ defined by $A(x_1, \dots, x_n) = (-x_1, \dots, -x_n)$ has $d(A) = (-1)^{n+1}$.*

Proof. From Corollary 1.21 A is the composition of $(n+1)$ -maps, all having degree -1 . □

EXERCISE 8. Show that for $n > 0$ and m any integer, there exists a map $f: S^n \rightarrow S^n$ of degree m .

1.23 Proposition. *If $f, g: S^n \rightarrow S^n$ are maps with $f(x) \neq g(x)$ for all x in S^n , then g is homotopic to $A \circ f$.*

Proof. Graphically the idea is as follows: since $g(x) \neq f(x)$, the segment in \mathbb{R}^{n+1} from $Af(x)$ to $g(x)$ does not pass through the origin. Thus, projecting out from the origin onto the sphere yields a path in S^n between $Af(x)$ and $g(x)$ (Figure 1.11). These are the paths which produce the desired homotopy. In particular we define a function

$$F: S^n \times I \rightarrow S^n$$

by

$$F(x, t) = \frac{(1-t)Af(x) + t \cdot g(x)}{\|(1-t)Af(x) + t \cdot g(x)\|}$$

which gives the homotopy explicitly. □

1.24 Corollary. *If $f: S^{2n} \rightarrow S^{2n}$ is a map, then there exists an x in S^{2n} with $f(x) = x$ or there exists a y in S^{2n} with $f(y) = -y$.*

Proof. If $f(x) \neq x$ for all x , then by Proposition 1.23 f is homotopic to A . On the other hand, if $f(x) \neq -x = A(x)$ for all x , then f is homotopic to $A \circ A = \text{identity}$.

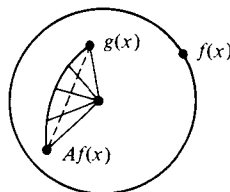

Figure 1.11

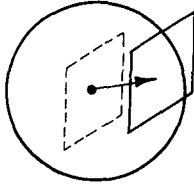

Figure 1.12

When both of these conditions hold, we have

$$d(A) = d(f) = d(\text{identity}).$$

However, $d(A) = (-1)^{2n+1} = -1$ and $d(\text{identity}) = 1$, and the two conditions cannot hold simultaneously. \square

1.25 Corollary. *There is no continuous map $f: S^{2n} \rightarrow S^{2n}$ such that x and $f(x)$ are orthogonal for all x .* \square

Although these ideas have not been defined, S^n is a manifold of dimension n . That is, it is locally homeomorphic to \mathbb{R}^n . As such it has a tangent space $T(S^n, x)$ at each point x in S^n . With S^n identified with the unit sphere in \mathbb{R}^{n+1} , $T(S^n, x)$ is the n -dimensional hyperplane in \mathbb{R}^{n+1} which is tangent to S^n at x (Figure 1.12). We may translate this hyperplane to the origin where it becomes the n -dimensional subspace orthogonal to the vector x . Of course, as x varies over S^n , these subspaces will vary accordingly. A *vector field* on S^n is a continuous function assigning to each x in S^n a vector in the corresponding linear subspace. A vector field ϕ is nonzero if $\phi(x) \neq 0$ for each x in S^n .

1.26 Corollary. *There exists no nonzero vector field on S^{2n} .*

Proof. If ϕ is a nonzero vector field on S^{2n} , then $\psi(x) = \phi(x)/\|\phi(x)\|$ is a vector field on S^{2n} of unit length. Thus, $\psi: S^{2n} \rightarrow S^{2n}$ is a map for which $\psi(x)$ is orthogonal to x for each x . But this is impossible by Corollary 1.25. Hence, no such vector field exists. \square

Nonzero vector fields always exist on odd-dimensional spheres. A collection of vector fields ϕ_1, \dots, ϕ_k on S^n is linearly independent if for each x in S^n the vectors $\phi_1(x), \dots, \phi_k(x)$ are linearly independent. A famous problem in mathematics is the determination of the maximum number of linearly independent vector fields which exist on S^{2n+1} for each value of n . The work of Hurwitz and Radon [see Eckmann, 1942] gives a strong positive result; that is, a specific number of linearly independent vector fields (varying with the dimension of the sphere) is shown to exist. The solution of the problem was

completed by Adams [1962] who showed that these positive results were the best possible.

Before proceeding with further applications, we digress in order to introduce some necessary algebraic ideas. A *directed set* Λ is a set with a partial order relation \leq such that given elements a and b in Λ there exists an element c in Λ with $a \leq c$ and $b \leq c$. A *direct system of sets* is a family of sets $\{X_a\}_{a \in \Lambda}$, where Λ is a directed set, and functions

$$f_a^b: X_a \rightarrow X_b \quad \text{whenever } a \leq b,$$

satisfying the following requirements:

- (i) $f_a^a = \text{identity on } X_a$ for each a in Λ ;
- (ii) if $a \leq b \leq c$, then $f_a^c = f_b^c \circ f_a^b$.

The particular case of interest to us is where the X_a are abelian groups and the f_a^b are homomorphisms. So let $\{X_a, f_a^b\}$ be a direct system of abelian groups and homomorphisms. Define a subgroup R of $\sum_a X_a$ as follows:

$$R = \left\{ \sum_{i=1}^n x_{a_i} \mid \text{there exists a } c \in \Lambda, c \geq a_i \text{ for all } i, \text{ and } \sum_{i=1}^n f_{a_i}^c(x_{a_i}) = 0 \right\}.$$

Then the *direct limit* of the system $\{X_a, f_a^b\}$ is the group

$$\lim_{\rightarrow} X_a = \sum_a X_a / R.$$

Note that if x_a is in X_a and x_b is in X_b , then they will be equal in the direct limit if for some c in Λ , $c \geq a$ and $c \geq b$ and $f_a^c(x_a) = f_b^c(x_b)$.

1.27 Lemma. *Let X be a space and denote by $\{X_a\}$ the family of all compact subsets of X , partially ordered by inclusion. Then the family of groups $\{H_*(X_a)\}$ forms a direct system where the homomorphisms are induced by the inclusion maps. Then*

$$\lim_{\rightarrow} H_*(X_a) \approx H_*(X).$$

Proof. For each X_a , let the homomorphism

$$g_{a*}: H_*(X_a) \rightarrow H_*(X)$$

be induced by the inclusion map. Then set

$$g = \sum_a g_{a*}: \sum_a H_*(X_a) \rightarrow H_*(X).$$

Now suppose that $\sum_{i=1}^n x_{a_i}$ is in R ; that is, there exists a compact subset $X_b \subseteq X$ such that $X_{a_i} \subseteq X_b$ for each i and

$$\sum_{i=1}^n g_{a_i*}^b(x_{a_i}) = 0 \quad \text{in } H_*(X_b).$$

Then from the commutativity of the diagram

$$\begin{array}{ccc}
 & H_*(X_b) & \\
 \nearrow \Sigma g_{a_i}^{b,*} & & \searrow g_{b,*} \\
 \sum_{i=1}^n H_*(X_{a_i}) & \xrightarrow{g} & H_*(X)
 \end{array}$$

it follows that $g(\sum_{i=1}^n x_{a_i}) = 0$ and R is contained in the kernel of g . Thus, g induces a homomorphism

$$\bar{g}: \sum_a H_*(X_a)/R = \varinjlim_a H_*(X_a) \rightarrow H_*(X).$$

For any homology class x in $H_n(X)$, represent x by a cycle $\sum n_j \phi_j$. Since σ_n is compact, $\phi_j(\sigma_n)$ is compact in X for each j . Then the chain $\sum n_j \phi_j$ is “supported” on the set $\bigcup_j \phi_j(\sigma_n)$, which is compact since the sum is finite. Thus

$$\bigcup_j \phi_j(\sigma_n) = X_a \quad \text{for some } a,$$

and $\sum n_j \phi_j$ must represent some homology class x_a in $H_n(X_a)$. Moreover, it is evident that $g_{a,*}(x_a) = x$; hence, x is in the image of \bar{g} and \bar{g} is an epimorphism.

Now suppose that $\sum_{i=1}^n x_{a_i}$ is in $\sum_a H_n(X_a)$ with $g(\sum_{i=1}^n x_{a_i}) = 0$. Each x_{a_i} may be represented by a cycle $\sum_j n_{ij} \phi_{ij}$ in X_{a_i} . Then $g(\sum_{i=1}^n x_{a_i})$ is represented in X by the cycle $\sum_{i,j} n_{ij} \phi_{ij}$. Since we have assumed that this cycle bounds, there exists an $(n + 1)$ -chain $\sum_k m_k \psi_k$ in X with $\partial(\sum m_k \psi_k) = \sum_{i,j} n_{ij} \phi_{ij}$. Once again define a subset of X by

$$X_b = \left[\bigcup_k \psi_k(\sigma_{n+1}) \right] \cup \left[\bigcup_i X_{a_i} \right],$$

and note that X_b is compact. Since $\sum m_k \psi_k$ is an $(n + 1)$ -chain in X_b with $\partial(\sum m_k \psi_k) = \sum_{i,j} n_{ij} \phi_{ij}$, it follows that

$$\sum_{i=1}^n g_{a_i,*} \left(\sum_j n_{ij} \phi_{ij} \right) \quad \text{is a boundary in } S_n(X_b)$$

and

$$\sum_{i=1}^n g_{a_i,*}(x_{a_i}) = 0 \quad \text{in } H_n(X_b).$$

Thus, $\sum_{i=1}^n x_{a_i}$ is in R , $R = \text{kernel of } g$, and \bar{g} is an isomorphism. □

1.28 Lemma. *If $A \subseteq S^n$ is a subset with A homeomorphic to I^k , $0 \leq k \leq n$, then*

$$H_j(S^n - A) \approx \begin{cases} \mathbb{Z} & \text{for } j = 0 \\ 0 & \text{for } j > 0. \end{cases}$$

Proof. Proceeding by induction on k , if $k = 0$ then A is a point and $S^n - A$ is homeomorphic to \mathbb{R}^n from which the conclusion follows. Assume then that

the result is true for $k < m$ and let

$$h: A \rightarrow I^m$$

be a homeomorphism. Split the m -cube I^m into its upper and lower halves by setting

$$I^+ = \{(x_1, \dots, x_m) \in I^m \mid x_1 \geq 0\} \quad \text{and} \quad I^- = \{(x_1, \dots, x_m) \in I^m \mid x_1 \leq 0\}$$

so that $I^+ \cap I^-$ is homeomorphic to I^{m-1} . For the corresponding decomposition of A denote by $A^+ = h^{-1}(I^+)$ and $A^- = h^{-1}(I^-)$. The set $S^n - (A^+ \cap A^-)$ may be written as the union of two sets $(S^n - A^+) \cup (S^n - A^-)$ satisfying the requirements of the Mayer–Vietoris sequence. So there is an exact sequence

$$\begin{aligned} H_{j+1}(S^n - (A^+ \cap A^-)) &\rightarrow H_j(S^n - A) \rightarrow H_j(S^n - A^+) \oplus H_j(S^n - A^-) \\ &\rightarrow H_j(S^n - (A^+ \cap A^-)). \end{aligned}$$

By the inductive hypothesis, for $j > 0$ the end terms are both zero. This yields an isomorphism

$$H_j(S^n - A) \xrightarrow{i_* \oplus i_*^{-1}} H_j(S^n - A^+) \oplus H_j(S^n - A^-).$$

So if $x \in H_j(S^n - A)$ and $x \neq 0$, then either $i_*^+(x) \neq 0$ or $i_*^-(x) \neq 0$. Suppose $i_*^+(x) \neq 0$. Now repeat the procedure by splitting A^+ into two pieces whose intersection is homeomorphic to I^{m-1} . In this manner a sequence of subsets of S^n may be constructed $A = A_1 \supseteq A_2 \supseteq A_3 \supseteq \dots$ having the property that the inclusion

$$S^n - A \subseteq S_n - A_k$$

induces a homomorphism on homology taking x into a nonzero element of $H_j(S^n - A_k)$, and furthermore that $\bigcap_i A_i$ is homeomorphic to I^{m-1} .

Now every compact subset of $(S^n - \bigcap_i A_i)$ will be contained in some $(S^n - A_k)$. Thus the isomorphism of Lemma 1.27 factors through the direct limit

$$\lim_{\overrightarrow{k}} H_j(S^n - A_k),$$

so that this direct limit must also be isomorphic to $H_j(S^n - \bigcap_i A_i)$. By the construction, the element of this direct limit represented by x is nonzero; however, by the inductive hypothesis the group $H_j(S^n - \bigcap_i A_i) = 0$. This contradiction implies that no such element x exists and $H_j(S^n - A) = 0$.

For the case $j = 0$, the Mayer–Vietoris sequence yields a monomorphism rather than an isomorphism. If x and y are points in $S^n - A$ with $(x - y) \neq 0$ in $H_0(S^n - A)$, then the above argument may be duplicated to imply that $(x - y)$ must be nonzero in $H_0(S^n - \bigcap_i A_i)$, a contradiction. \square

1.29 Corollary. *If $B \subseteq S^n$ is a subset homeomorphic to S^k for $0 \leq k \leq n - 1$, then $H_*(S^n - B)$ is a free abelian group with two generators, one in dimension zero and one in dimension $n - k - 1$.*

Proof. Once again inducting on k , note that for $k = 0$, S^k is two points and $S^n - B$ has the homotopy type of S^{n-1} . Since $H_*(S^{n-1})$ satisfies the description, the result is true for $k = 0$. Suppose the result is true for $k - 1$ and write $B = B^+ \cup B^-$, where B^+ and B^- are homeomorphic to closed hemispheres in S^k and $B^+ \cap B^-$ is homeomorphic to S^{k-1} . The Mayer-Vietoris sequence of the covering

$$S^n - (B^+ \cap B^-) = (S^n - B^+) \cup (S^n - B^-)$$

has the form

$$\begin{aligned} H_{j+1}(S^n - B^+) \oplus H_{j+1}(S^n - B^-) &\rightarrow H_{j+1}(S^n - (B^+ \cap B^-)) \\ &\rightarrow H_j(S^n - B) \\ &\rightarrow H_j(S^n - B^+) \oplus H_j(S^n - B^-). \end{aligned}$$

For $j > 0$, both of the end terms are zero by Lemma 1.28. The resulting isomorphism furnishes the inductive step necessary to complete the proof. \square

This result may now be applied to prove the following famous theorem.

1.30 Theorem (Jordan-Brouwer Separation Theorem). *An $(n - 1)$ -sphere imbedded in S^n separates S^n into two components and it is the boundary of each component.*

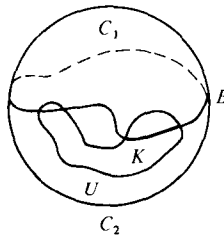

Figure 1.13

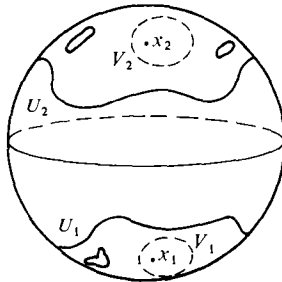

Figure 1.14

Proof. Let $B \subseteq S^n$ be the imbedded copy of S^{n-1} . Then by Corollary 1.29, $H_*(S^n - B)$ is free abelian with two basis elements, both of dimension zero. So $S^n - B$ has two path components. B is closed, so $S^n - B$ is open and hence locally pathwise connected. This implies that the path components are components.

Let C_1 and C_2 be the components of $S^n - B$. Since $C_1 \cup B$ is closed, the boundary of C_1 is contained in B . (Here we mean by the boundary of C_1 , the set $\partial C_1 = \overline{C_1} - C_1^0$.) The proof will be complete when we show that $B \subseteq \partial C_1$. Let $x \in B$ and U be a neighborhood of x in S^n . Since B is an imbedded copy of S^{n-1} , there is a subset K of $U \cap B$ with $x \in K$ and $B - K$ homeomorphic to D^{n-1} (Figure 1.13).

Now by Lemma 1.28 $H_*(S^n - (B - K)) \approx Z$ with generator in dimension zero. Thus, $S^n - (B - K)$ has one path component. Let $p_1 \in C_1$, $p_2 \in C_2$ and γ a path in $S^n - (B - K)$ between p_1 and p_2 . Since C_1 and C_2 are distinct path components in $S^n - B$, the path γ must intersect K . As a result, K contains points of $\overline{C_1}$ and $\overline{C_2}$.

We have shown that an arbitrary neighborhood of x contains points of both $\overline{C_1}$ and $\overline{C_2}$, hence x is in the boundary of C_1 and the proof is complete. \square

One final application is the *Brouwer theorem on the invariance of domain*.

1.31 Theorem. Suppose that U_1 and U_2 are subsets of S^n and that $h: U_1 \rightarrow U_2$ is a homeomorphism. Then if U_1 is open, U_2 is also open.

Note. It should be observed that this is a nontrivial fact. Of course, it is obviously true if “open” is replaced by “closed,” or if the homeomorphism is assumed to be defined over all of S^n . This need not be true in spaces in general. For example, let $W_1 = (\frac{1}{2}, 1]$ and $W_2 = (0, \frac{1}{2}]$ be subsets of $[0, 1]$. If $h: W_1 \rightarrow W_2$ is given by $h(x) = x - \frac{1}{2}$, then h is a homeomorphism, W_1 is open, but W_2 is not. It should be evident that there is no extension of h to a homeomorphism of $[0, 1]$ onto itself.

Proof. Suppose $x_2 = h(x_1)$ is some point in U_2 . Let V_1 be a neighborhood of x_1 in U_1 with V_1 homeomorphic to D^n and ∂V_1 homeomorphic to S^{n-1} . Set $V_2 = h(V_1)$ and denote by $\partial V_2 = h(\partial V_1)$, so that ∂V_2 is a subset of S^n homeomorphic to S^{n-1} (Figure 1.14).

Then by Lemma 1.28 $S^n - V_2$ is connected, while by Theorem 1.30 $S^n - \partial V_2$ has two components. So $S^n - \partial V_2$ is the disjoint union of $S^n - V_2$ and $V_2 - \partial V_2$, both of which are connected. Hence, they are the components of $S^n - \partial V_2$. This implies that $V_2 - \partial V_2$ is open, contained in U_2 , and $x_2 \in V_2 - \partial V_2$. Hence, U_2 is open. \square

CHAPTER 2

Attaching Spaces with Maps

The purpose of this chapter is to develop the basic theory of CW complexes and their homology groups. An equivalence relation on a topological space is seen to produce a new space whose points are the equivalence classes. This gives a means of attaching one space to another via a mapping from a subspace of the first to the second. The case of particular interest is that of attaching a cell to a space via a map defined on the boundary. This leads naturally to the definition of CW complexes. To serve as tools in the study of these spaces, relative homology groups are introduced and the excision theorem is proved. It is shown that the relative groups of adjacent skeletons produce a finitely generated chain complex whose homology is the homology of the space, and this is applied to compute the homology of real projective spaces.

Recall that a relation \sim on a set A is an *equivalence relation* if the following are satisfied:

- (i) $a \sim a$,
- (ii) $a \sim b \Rightarrow b \sim a$,
- (iii) $a \sim b, b \sim c \Rightarrow a \sim c$,

for all a, b , and c in A . Such a relation on A gives a decomposition of A into equivalence classes. On the other hand, a decomposition of A into disjoint subsets defines an equivalence relation on A ($a \sim b \Leftrightarrow a$ and b are in the same subset) under which these subsets are the equivalence classes. Denote by A/\sim the set of equivalence classes under \sim . By the *quotient function* $\pi: A \rightarrow A/\sim$ we mean the function which assigns to $a \in A$ the equivalence class containing a .

More generally, if $f: A \rightarrow B$ is a function of sets, there is naturally associated an equivalence relation on A . Specifically, $a_1 \sim a_2$ if and only if $f(a_1) =$

$f(a_2)$. In particular if $B = A/\sim$, for some equivalence relation \sim , and $f = \pi$, then we recover the original relation \sim in this way.

Now suppose \sim is an equivalence relation on a topological space X . The quotient space X/\sim may be topologized by defining a subset $U \subseteq X/\sim$ to be open if and only if $\pi^{-1}(U)$ is open in X . Note that under this topology, π becomes a continuous function.

Since our main interest is in Hausdorff spaces, we will want to restrict our attention to those equivalence relations on a Hausdorff space X for which the quotient space X/\sim is Hausdorff. For example define an equivalence relation on $[-1, 1]$ by $a \sim -a$ if $|a| < 1$ and $a \sim a$ for all a . Then the images of 1 and -1 in the quotient space cannot be separated by mutually disjoint open sets.

If X is a topological space define

$$D = \{(x, x) | x \in X\} \subseteq X \times X$$

the *diagonal* in $X \times X$. Recall that X is Hausdorff if and only if the diagonal is a closed subset of $X \times X$. Now let \sim be an equivalence relation on X and denote by Δ the diagonal in $(X/\sim) \times (X/\sim)$. Note that the continuous function

$$\pi \times \pi: X \times X \rightarrow (X/\sim) \times (X/\sim)$$

has

$$(\pi \times \pi)^{-1}(\Delta) = \{(x, y) | x \sim y\}.$$

This subset of $X \times X$ is the *graph of the relation*. The relation \sim on X is *closed* if and only if its graph is a closed subset of $X \times X$. It is evident from the above that if X/\sim is a Hausdorff space, then \sim is a closed relation on X . We now show that the converse is true whenever X is compact.

2.1 Proposition. *If \sim is a closed relation on a compact Hausdorff space, then X/\sim is Hausdorff.*

Proof. Recall that a subset of a compact Hausdorff space is closed if and only if it is compact. Denote by p_1 and p_2 the projection maps of $X \times X$ onto the first and second factors, respectively. Let C be a closed subset of X and $G \subseteq X \times X$ the graph of \sim . Then

$$\begin{aligned} p_2(p_1^{-1}(C) \cap G) &= \{y \in X | y \sim x \text{ for some } x \in C\} \\ &= \pi^{-1}(\pi(C)). \end{aligned}$$

Now $p_1^{-1}(C) \cap G$ is closed, hence compact, and so $p_2(p_1^{-1}(C) \cap G)$ is compact, hence closed. Thus, for any closed $C \subseteq X$, $\pi^{-1}(\pi(C))$ is closed in X ; hence, $\pi(C)$ is closed in X/\sim .

If \bar{x} and $\bar{y} \in X/\sim$ are distinct points, then they are closed in X/\sim since they are images of single points in X . Thus, $\pi^{-1}(\bar{x})$ and $\pi^{-1}(\bar{y})$ are disjoint closed subsets of X . Since X is compact Hausdorff, it is normal, and there exist open sets U, V , in X containing $\pi^{-1}(\bar{x})$ and $\pi^{-1}(\bar{y})$, respectively, with

$U \cap V = \emptyset$. Let U' and V' be the complements of U and V , so that $\pi(U')$ and $\pi(V')$ are closed subsets of X/\sim . Then their complements $X/\sim - \pi(U')$ and $X/\sim - \pi(V')$ are open, disjoint and contain \bar{x} and \bar{y} , respectively. Thus, X/\sim is Hausdorff. \square

EXERCISE 1. (a) Give an example of a closed relation \sim on a Hausdorff space X such that $\pi: X \rightarrow X/\sim$ is not a closed mapping.

(b) Give an example of a closed relation \sim on a Hausdorff space X such that X/\sim is not Hausdorff.

If a partial relation \sim' is given on a space X , it is possible to associate with \sim' a specific equivalence relation on X . Define an equivalence relation \sim on X by $x \sim y$ if there exists a sequence x_0, \dots, x_n in X with $x_0 = x, x_n = y$, and

- (i) $x_{i+1} = x_i$ or
- (ii) $x_{i+1} \sim' x_i$ or
- (iii) $x_i \sim' x_{i+1}$

for each i . Then \sim is the *equivalence relation generated by \sim'* . It is the least equivalence relation that preserves all of the relations from \sim' .

For example, let $X = S^n, n \geq 1$, and define \sim to be the least equivalence relation on S^n for which $x \sim -x$ for all x . The graph of \sim in $S^n \times S^n$ is the union of the diagonal D and the antidiagonal $D' = \{(x, -x) | x \in S^n\}$. This is obviously closed; hence, S^n/\sim is a compact Hausdorff space called *real projective n -space*, $\mathbb{R}P(n)$.

Suppose A, X , and Y are spaces with $A \subseteq X$ and $X \cap Y = \emptyset$. Let $f: A \rightarrow Y$ be a continuous function. We consider $X \cup Y$ as a topological space in which X and Y are both open and closed, carrying their original topologies. Let \sim be the least equivalence relation on $X \cup Y$ such that $x \sim f(x)$ for all $x \in A$. The identification space $X \cup Y/\sim$ is the *space obtained by attaching X to Y via $f: A \rightarrow Y$* . It is customary to denote $X \cup Y/\sim$ by $X \cup_f Y$.

EXERCISE 2. Suppose in the above that X and Y are Hausdorff spaces and A is closed in X . Then show that \sim is a closed relation.

2.2 Corollary. *If X and Y are compact Hausdorff spaces, A is closed in X and $f: A \rightarrow Y$ is continuous, then $X \cup_f Y$ is a compact Hausdorff space.* \square

It is not difficult to see that there is a homeomorphic copy of Y sitting in $X \cup_f Y$. We denote by $i: Y \rightarrow X \cup_f Y$ the homeomorphism onto this subspace; i may be thought of as the composition of the inclusion of Y in $X \cup Y$ followed by the quotient map $\pi: X \cup Y \rightarrow X \cup_f Y$.

A case of particular importance is when $X = D^n$ and $A = S^{n-1} = \partial D^n$. The space $D^n \cup_f Y$ is called the space obtained by *attaching an n -cell to Y via f* . When it may be done without causing confusion, we will denote $D^n \cup_f Y$ by Y_f .

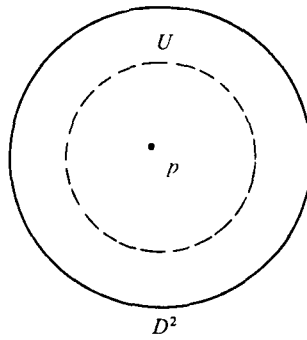

Figure 2.1

EXAMPLE. Let $X = D^2$, $A = S^1 = \partial D^2$ and Y be a copy of S^1 disjoint from X . Let $f: A \rightarrow Y$ be the standard map of degree two given in complex coordinates by $f(e^{i\theta}) = e^{2i\theta}$. The identification space $X \cup_f Y$ is then the *real projective plane*, $\mathbb{R}P(2)$.

The homology groups of this space may be computed by applying the Mayer–Vietoris sequence. In the interior of D^2 pick an open cell U and a point p contained in U (see Figure 2.1). Setting $V = \mathbb{R}P(2) - \{p\}$, consider the Mayer–Vietoris sequence of the covering $\{U, V\}$. $U \cap V$ and V both have the homotopy type of S^1 , whereas U is contractible. In the portion of the sequence given by

$$\begin{array}{ccc} H_1(U \cap V) & \xrightarrow{\alpha} & H_1(U) \oplus H_1(V) \xrightarrow{\beta} H_1(\mathbb{R}P(2)) \\ \cong & & \cong \\ Z & & Z \end{array}$$

it is easy to check that β is an epimorphism. A generating one-cycle in $U \cap V$, when retracted out onto the boundary, is wrapped twice around S^1 since f has degree two. Thus, α is a monomorphism onto $2Z$, and $H_1(\mathbb{R}P(2)) \approx Z/2Z = Z_2$.

Moreover, the connecting homomorphism

$$H_2(\mathbb{R}P(2)) \xrightarrow{\Delta} H_1(U \cap V)$$

is a monomorphism whose image is the kernel of α , so $H_2(\mathbb{R}P(2)) = 0$. All higher-dimensional homology groups are easily seen to be zero, and $\mathbb{R}P(2)$ is pathwise connected, so its homology is completely determined.

The technique used in this example may easily be adapted to prove the following proposition:

2.3 Proposition. *If $f: S^{n-1} \rightarrow Y$ is continuous where Y is Hausdorff, then there is an exact sequence*

$$\begin{aligned} \cdots \rightarrow H_m(S^{n-1}) \xrightarrow{f_*} H_m(Y) \xrightarrow{i_*} H_m(Y_f) \xrightarrow{\Delta} H_{m-1}(S^{n-1}) \rightarrow \cdots \\ \rightarrow H_0(S^{n-1}) \rightarrow H_0(Y) \oplus Z \rightarrow H_0(Y_f). \end{aligned} \quad \square$$

This exact sequence shows how closely related are the homology groups of Y and Y_f . If an n -cell has been attached to Y , then $H_n(Y) \xrightarrow{i_*} H_n(Y_f)$ is a monomorphism with cokernel either zero or infinite cycle. In this sense we may have created a new n -dimensional “hole.” On the other hand, $H_{n-1}(Y) \xrightarrow{i_*} H_{n-1}(Y_f)$ is an epimorphism with kernel either zero or cyclic, so the effect of this new n -cell may have been to fill an existing $(n - 1)$ -dimensional “hole” in Y . Away from these dimensions, the addition of an n -cell does not affect the homology.

Let (X, A) be a pair of spaces and $Y = \text{point}$. Then there is only one map $A \xrightarrow{f} Y$ for $A \neq \emptyset$. The space $X \cup_f Y$ is then denoted by X/A because it can be pictured as the space formed from X by collapsing A to a point. Note that if X is compact Hausdorff and A is closed in X , then X/A is compact Hausdorff.

2.4 Proposition. *If X and W are compact Hausdorff spaces and $g: X \rightarrow W$ is a continuous function onto W such that for some $w_0 \in W$, $g^{-1}(w_0)$ is a closed set $A \subseteq X$, and for $w \neq w_0$, $g^{-1}(w)$ is a single point of X , then W is homeomorphic to X/A .*

This follows immediately from the following more general fact.

2.5 Proposition. *Suppose X, Y , and W are compact Hausdorff spaces and A is a closed subset of X . Let $f: A \rightarrow Y$ be continuous and $g: X \cup Y \rightarrow W$ continuous and onto. If for each $w \in W$, $g^{-1}(w)$ is either a single point of $X - A$ or the union of a single point $y \in Y$ together with $f^{-1}(y)$ in A , then W is homeomorphic to $X \cup_f Y$.*

Proof. If $\pi: X \cup Y \rightarrow X \cup_f Y$ is the identification map, g may be factored through π to give a commutative triangle

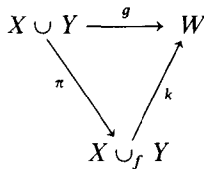

where k is induced by g . Then k is one to one and onto by the properties of g . To see that k is continuous, let C be closed in W . Then $k^{-1}(C)$ is closed if and only if $\pi^{-1}k^{-1}(C)$ is closed. But $\pi^{-1}k^{-1}(C) = g^{-1}(C)$, which is closed since g is continuous. Since $X \cup_f Y$ and W are compact Hausdorff spaces, k is a homeomorphism. □

EXAMPLE. Consider S^{n-1} as the boundary of D^n and let $h_1: D^n - S^{n-1} \rightarrow \mathbb{R}^n$ be a homeomorphism. Let $z \in S^n$ and set $h_2: S^n - \{z\} \rightarrow \mathbb{R}^n$ to be the homeomorphism given by stereographic projection. Now define a function

$$g: D^n \rightarrow S^n \quad \text{by} \quad g(x) = \begin{cases} z & \text{if } x \in S^{n-1} \\ h_2^{-1}h_1(x) & x \in D^n - S^{n-1}. \end{cases}$$

Then checking that g satisfies the hypothesis of Proposition 2.4 with $A = S^{n-1}$ we conclude that D^n/S^{n-1} is *homeomorphic to S^n* . Thus, S^n may be viewed as the space given by attaching n -cell to a point.

Many of the spaces which concern algebraic topologists may be constructed in a similar fashion, that is, by repeatedly attaching cells of varying dimensions to a finite set of points. Before giving a formal definition, we consider a number of important examples.

EXAMPLE. Recall that $\mathbb{R}P(n) = S^n/\sim$, where \sim is the least equivalence relation on S^n having $x \sim -x$ for all x . Denote by $\pi: S^n \rightarrow \mathbb{R}P(n)$ the quotient map. What space is produced by attaching an $(n+1)$ -cell to $\mathbb{R}P(n)$ via π ?

Regard $S^n \subseteq S^{n+1}$ by identifying $(x_1, \dots, x_{n+1}) \in S^n$ with $(x_1, \dots, x_{n+1}, 0) \in S^{n+1}$. This induces an inclusion map $i: \mathbb{R}P(n) \rightarrow \mathbb{R}P(n+1)$, of a closed subset. Write S^{n+1} as the union of two subsets $E_+^{n+1} \cup E_-^{n+1}$ which correspond to the upper and lower closed hemispheres, that is, $E_+^{n+1} \cap E_-^{n+1} = S^n$.

There is a homeomorphism $g: D^{n+1} \rightarrow E_+^{n+1}$. Denote by $f_1: D^{n+1} \rightarrow \mathbb{R}P(n+1)$ the composition of the maps

$$D^{n+1} \xrightarrow{g} E_+^{n+1} \subseteq S^{n+1} \xrightarrow{h} \mathbb{R}P(n+1),$$

where h is the quotient map on S^{n+1} .

Thus, we have a mapping of the union

$$D^{n+1} \cup \mathbb{R}P(n) \xrightarrow{f_1 \cup i} \mathbb{R}P(n+1).$$

It is not difficult to check that $f_1 \cup i$ is onto; in fact, f_1 is onto. Note that for $z \in \mathbb{R}P(n+1)$, $f_1^{-1}(z)$ is either a single point of $D^{n+1} - S^n$ or a pair $\{x, -x\}$ in S^n , the latter being true if and only if z lies in the subspace $\mathbb{R}P(n)$. Thus, the hypotheses of Proposition 2.5 are satisfied and we conclude that $\mathbb{R}P(n+1)$ is *homeomorphic to $D^{n+1} \cup_{\pi} \mathbb{R}P(n)$, the space given by attaching an $(n+1)$ -cell to $\mathbb{R}P(n)$ via π* .

Suppose X and Y are topological spaces and $x_0 \in X$, $y_0 \in Y$ are base points. In $X \times Y$ there are the subsets $\{x_0\} \times Y$ and $X \times \{y_0\}$. Define $X \vee Y$, the *wedge of X and Y* , to be the union of these two subsets,

$$X \times \{y_0\} \cup \{x_0\} \times Y.$$

EXAMPLE. Denote by I the unit interval in \mathbb{R}^1 , $\partial I = \{0, 1\}$. The n -cube

$$I^n \subseteq \mathbb{R}^n \quad \text{has} \quad \partial I^n = \{(x_1, \dots, x_n) \mid \text{some } x_i = 0 \text{ or } 1\}.$$

So $I^m \times I^n = I^{m+n}$ and

$$\partial(I^{m+n}) = (\partial I^m \times I^n) \cup (I^m \times \partial I^n).$$

Let $z_m \in S^m$ and $z_n \in S^n$ be base points. There exists a map of pairs $f: (I^m, \partial I^m) \rightarrow (S^m, z_m)$, which is a relative homeomorphism; similarly there is a $g: (I^n, \partial I^n) \rightarrow (S^n, z_n)$. Taking cartesian products gives a map

$$f \times g: I^m \times I^n \rightarrow S^m \times S^n.$$

To see what happens on $\partial(I^m \times I^n)$ note that

$$I^{m+n} - \partial(I^{m+n}) = (I^m - \partial I^m) \times (I^n - \partial I^n).$$

From the properties of f and g , $f \times g$ maps this one to one onto

$$\begin{aligned} (S^m - z_m) \times (S^n - z_n) &= S^m \times S^n - (S^m \times \{z_n\} \cup \{z_m\} \times S^n) \\ &= S^m \times S^n - S^m \vee S^n. \end{aligned}$$

Furthermore, $f \times g$ maps $\partial(I^{m+n})$ onto $S^m \vee S^n$, so by Proposition 2.5, $S^m \times S^n$ is homeomorphic to the space obtained by attaching an $(m+n)$ -cell to $S^m \vee S^n$ via the map

$$\partial(I^{m+n}) \approx S^{m+n-1} \rightarrow S^m \vee S^n.$$

$S^m \times S^n$ is called a *generalized torus*.

EXAMPLE. For each integer n identify \mathbb{R}^{2n} with \mathbb{C}^n and denote the points by (z_1, \dots, z_n) . Then $S^{2n-1} \subseteq \mathbb{C}^n$ is given by

$$S^{2n-1} = \{(z_1, \dots, z_n) \mid \sum |z_i|^2 = 1\}.$$

Define an equivalence relation on S^{2n-1} by $(z_1, \dots, z_n) \sim (z'_1, \dots, z'_n)$ if and only if there exists a complex number λ with $|\lambda| = 1$ such that $z'_1 = \lambda z_1, \dots, z'_n = \lambda z_n$. This is a closed relation, and the space S^{2n-1}/\sim is denoted $\mathbb{C}P(n-1)$, $(n-1)$ -dimensional complex projective space. [This because its complex dimension is $(n-1)$, real dimension $(2n-2)$.] Recall that in the case of real projective space, a point on the sphere determined a unique real line through the origin and the point was set equivalent to all other points on that line, that is, the antipodal point. In the complex case, a point on the sphere determines a unique complex line through the origin and the point is identified with all other points on that line.

EXERCISE 3. Let $f: S^{2n-1} \rightarrow S^{2n-1}/\sim = \mathbb{C}P(n-1)$ be the identification map. Show that the space formed by attaching a $2n$ -cell to $\mathbb{C}P(n-1)$ via f is homeomorphic to $\mathbb{C}P(n)$.

For the case $n = 1$, any two points in S^1 are equivalent; hence, $\mathbb{C}P(0)$ is a point. Now $\mathbb{C}P(1)$ is formed by attaching D^2 to $\mathbb{C}P(0)$, which must yield S^2 . Thus, $\mathbb{C}P(1)$ is homeomorphic to S^2 . A matter of particular interest is the identification map

$$S^3 \rightarrow S^3/\sim = \mathbb{C}P(1) = S^2.$$

This map

$$h: S^3 \rightarrow S^2$$

is called the *Hopf map* and is of particular importance in homotopy theory.

EXAMPLE. In the same manner as for the complex number field, we may identify \mathbb{R}^4 with the division ring of quaternions by $(x_1, x_2, x_3, x_4) \rightarrow x_1 + ix_2 + jx_3 + kx_4$. This identifies \mathbb{R}^{4n} with \mathbb{H}^n , and the sphere

$$S^{4n-1} = \{(\alpha_1, \dots, \alpha_n) \in \mathbb{H}^n \mid \sum |\alpha_i|^2 = 1\}.$$

On S^{4n-1} set $(\alpha_1, \dots, \alpha_n) \sim (\alpha'_1, \dots, \alpha'_n)$ if there exists a $\gamma \in \mathbb{H}$ with $|\gamma| = 1$ such that $\alpha'_1 = \gamma\alpha_1, \dots, \alpha'_n = \gamma\alpha_n$. Then S^{4n-1}/\sim is $\mathbb{H}P(n-1)$, $(n-1)$ -dimensional quaternionic projective space. As before we find that $\mathbb{H}P(0) = pt$, $\mathbb{H}P(1) \approx S^4$ and $\mathbb{H}P(n)$ is the space given by attaching a $4n$ -cell to $\mathbb{H}P(n-1)$ via the identification map $S^{4n-1} \rightarrow \mathbb{H}P(n-1)$. The identification map $h: S^7 \rightarrow \mathbb{H}P(1) = S^4$ is once again called the *Hopf map*.

We now want to compute the homology groups of some of these examples. Leaving the real projective spaces for later in this chapter, first consider the generalized torus $S^m \times S^n$ and assume $m, n \geq 2$.

Recall that $S^m \times S^n$ is given by attaching an $(m+n)$ -cell to $S^m \vee S^n$. Denote by $-z_m$ and $-z_n$ the antipodes of the base points $z_m \in S^m$ and $z_n \in S^n$ (see Figure 2.2). Define

$$U = S^m \vee S^n - \{-z_n\} \quad \text{and} \quad V = S^m \vee S^n - \{-z_m\}.$$

Then $\{U, V\}$ gives an open covering of $S^m \vee S^n$, U admits a deformation retraction onto S^m , and V admits a deformation retraction onto S^n . Finally, note that $U \cap V$ has the homotopy type of a point. Thus, in the Mayer-Vietoris sequence for this covering we have

$$H_j(S^m) \oplus H_j(S^n) \approx H_j(S^m \vee S^n) \quad \text{for } j > 0.$$

Therefore, $H_*(S^m \vee S^n)$ is a free abelian group of rank three having one basis element of dimension zero one of dimension m and one of dimension n .

Now by Proposition 2.3 there is an exact sequence

$$\cdots \rightarrow H_i(S^{m+n-1}) \xrightarrow{f_*} H_i(S^m \vee S^n) \rightarrow H_i(S^m \times S^n) \rightarrow H_{i-1}(S^{m+n-1}) \rightarrow \cdots$$

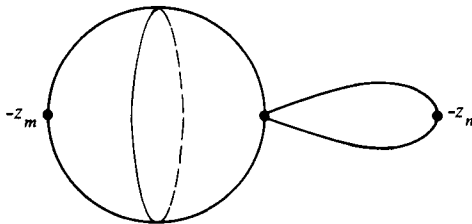

Figure 2.2

Since $m, n \geq 2$, $m + n - 1 > m$ and $m + n - 1 > n$. It follows that f_* is the zero map in positive dimensions. On the other hand, if $i = m + n$, the connecting homomorphism

$$H_i(S^m \times S^n) \rightarrow H_{i-1}(S^{m+n-1})$$

must be an isomorphism. This information may be combined with special arguments for dimensions zero and one to prove the following:

2.6 Proposition. $H_*(S^m \times S^n)$, $m, n \geq 0$, is a free abelian group of rank four having one basis element of each dimension $0, m, n$, and $m + n$. \square

Note. This is our first encounter with a nonspherical homology class. Let $\alpha \in H_k(S^k) \approx Z$ be a generator. An homology class $\beta \in H_k(X)$ is *spherical* if there exists a map $f: S^k \rightarrow X$ such that $f_*(\alpha) = \beta$. Specifically, if $\beta \in H_2(S^1 \times S^1)$ is a generator, then β is not spherical. Although we are not equipped to prove this at the present time, the basic reason is that β is a product of two one-dimensional homology classes, while $\alpha \in H_2(S^2)$ is not.

Next consider complex projective space $\mathbb{C}P(n)$. For $n = 0, 1$ we know $H_*(\mathbb{C}P(0)) \approx H_*(\text{pt})$ and $H_*(\mathbb{C}P(1)) \approx H_*(S^2)$.

2.7 Proposition

$$H_i(\mathbb{C}P(n)) \approx \begin{cases} Z & \text{for } i = 0, 2, 4, \dots, 2n \\ 0 & \text{otherwise.} \end{cases}$$

Proof. We proceed by induction on n . From the remarks above, the result is true for $n = 0$ or 1 . So suppose it is true for $n - 1 \geq 1$ and recall that $\mathbb{C}P(n)$ may be constructed by attaching a $2n$ -cell to $\mathbb{C}P(n - 1)$ via the identification map $f: S^{2n-1} \rightarrow \mathbb{C}P(n - 1)$. By Proposition 2.3 this yields an exact sequence

$$\dots \rightarrow H_i(S^{2n-1}) \xrightarrow{f_*} H_i(\mathbb{C}P(n - 1)) \xrightarrow{j_*} H_i(\mathbb{C}P(n)) \xrightarrow{\Delta} H_{i-1}(S^{2n-1}) \rightarrow \dots$$

for $i > 0$. For strictly algebraic reasons the homomorphism f_* must be zero in positive dimensions. So for $i > 1$, this gives a collection of short exact sequences

$$0 \rightarrow H_i(\mathbb{C}P(n - 1)) \xrightarrow{j_*} H_i(\mathbb{C}P(n)) \xrightarrow{\Delta} H_{i-1}(S^{2n-1}) \rightarrow 0.$$

These, together with the induction hypothesis, the fact that j_* is an epimorphism in dimension one and the fact that $\mathbb{C}P(n)$ is pathwise connected, complete the inductive step and the result follows. \square

2.8 Proposition

$$H_i(\mathbb{H}P(n)) \approx \begin{cases} Z & \text{for } i = 0, 4, 8, \dots, 4n \\ 0 & \text{otherwise.} \end{cases}$$

Proof. The proof of this is entirely analogous to that for Proposition 2.7. \square

With these examples in mind we now develop some of the basic properties of spaces constructed in this way. To do so it is necessary to introduce the *relative homology groups*, a useful generalization initiated by Lefschetz in the 1920s. The concept is entirely analogous to that of the quotient of a group by a subgroup. If A is a subspace of X then we set two chains of X equal modulo A if their difference is a chain in A . In particular a chain in X is a cycle modulo A if its boundary is contained in A . This reflects the structure of $X - A$ and the way that it is attached to A . In a sense, changes in the interior of A , away from its boundary with $X - A$, should not alter these homology groups.

To introduce the necessary homological algebra, let $C = \{C_n, \partial\}$ be a chain complex. $D = \{D_n, \partial\}$ is a *subcomplex* of C if $D_n \subseteq C_n$ for each n and the boundary operator for D is the restriction of the boundary operator for C . Define the *quotient chain complex*

$$C/D = \{C_n/D_n, \partial'\},$$

where $\partial'\{c\} = \{\partial c\}$ for $\{c\}$ the coset containing c . For convenience the prime will be omitted and all boundary operators will continue to be denoted by ∂ .

There is a natural short exact sequence of chain complexes and chain maps

$$0 \rightarrow D \xrightarrow{i} C \xrightarrow{\pi} C/D \rightarrow 0,$$

where i is the inclusion and π is the projection. From Theorem 1.13 this leads to a long exact sequence of homology groups

$$\cdots \rightarrow H_n(D) \xrightarrow{i_*} H_n(C) \xrightarrow{\pi_*} H_n(C/D) \xrightarrow{\Delta} H_{n-1}(D) \xrightarrow{i_*} \cdots$$

For clarity denote by $\{ \}$ the equivalence relation in C/D and by $\langle \rangle$ the equivalence relation in homology.

To see how the connecting homomorphism Δ is defined let $\{c\}$ be a cycle in $Z_n(C/D)$. To determine $\Delta(\langle \{c\} \rangle)$, represent $\{c\}$ by an element $c \in C_n$ having $\partial c \in D_{n-1}$. Of course, $\partial c \in Z_{n-1}(D)$ and hence represents a class in $H_{n-1}(D)$. Thus, we have

$$\Delta(\langle \{c\} \rangle) = \langle \partial c \rangle.$$

More generally, if $E \subseteq D \subseteq C$ are chain complexes and subcomplexes, there is a short exact sequence of chain complexes and chain maps

$$0 \rightarrow D/E \rightarrow C/E \rightarrow C/D \rightarrow 0$$

In the corresponding long exact homology sequence

$$\cdots \rightarrow H_n(D/E) \rightarrow H_n(C/E) \rightarrow H_n(C/D) \xrightarrow{\Delta} H_{n-1}(D/E) \rightarrow \cdots$$

the connecting homomorphism is given by $\Delta'(\langle \{c\} \rangle) = \langle \{\partial c\} \rangle$, which may be viewed as the composition

$$H_n(C/D) \xrightarrow{\Delta} H_{n-1}(D) \xrightarrow{\pi_*} H_{n-1}(D/E).$$

This is natural in the sense that if $E' \subseteq D' \subseteq C'$ are chain complexes and subcomplexes and $f: C \rightarrow C'$ is a chain map for which $f(D) \subseteq D'$ and $f(E) \subseteq E'$, then the induced homomorphisms on homology groups give a transformation between the long exact homology sequences in which each rectangle commutes.

By a *pair of spaces* (X, A) we mean a space X together with a subspace $A \subseteq X$. If (X, A) is a pair of spaces, $S_*(A)$ may be viewed as a subcomplex of $S_*(X)$. The *singular chain complex* of $X \bmod A$ is defined by

$$S_*(X, A) = S_*(X)/S_*(A).$$

The homology of this chain complex, the *relative singular homology* of $X \bmod A$, is thus given by

$$H_n(X, A) = H_n(S_*(X)/S_*(A)).$$

From the previous observations any pair (X, A) has an exact homology sequence

$$\cdots \rightarrow H_n(A) \xrightarrow{i_*} H_n(X) \xrightarrow{\pi_*} H_n(X, A) \xrightarrow{\Delta} H_{n-1}(A) \rightarrow \cdots.$$

In this sense $H_*(X, A)$ is a measure of how far $i_*: H_*(A) \rightarrow H_*(X)$ is from being an isomorphism. That is, i_* is an isomorphism of graded groups if and only if $H^*(X, A) = 0$. Thus, we have immediately the following:

2.9 Proposition. *If (X, A) is a pair for which A is a deformation retract of X , then $H_*(X, A) = 0$. \square*

More generally if (X, A, B) is a triple of spaces, that is, $B \subseteq A \subseteq X$, there results a short exact sequence of chain complexes

$$0 \rightarrow S_*(A, B) \rightarrow S_*(X, B) \rightarrow S_*(X, A) \rightarrow 0$$

which yields the corresponding long exact sequence of relative homology groups. It is conventional to define $S_*(\emptyset) = 0$ so that $H_*(X, \emptyset) = H_*(X)$ and all homology groups may be viewed as groups of pairs.

Given pairs (X, A) and (Y, B) a *map of pairs* $f: (X, A) \rightarrow (Y, B)$ is a continuous function $f: X \rightarrow Y$ for which $f(A) \subseteq B$. Note that for such a map $f_*(S_*(A)) \subseteq S_*(B)$, so that there is associated a homomorphism

$$f_\#: S_*(X, A) \rightarrow S_*(Y, B)$$

which is a chain map, hence also a homomorphism on the relative homology groups. Note that the homomorphisms of degree zero in the exact sequence of a triple are induced by the inclusion maps of pairs.

Two maps of pairs $f, g: (X, A) \rightarrow (Y, B)$ are *homotopic as maps of pairs* if there exists a map of pairs

$$F: (X \times I, A \times I) \rightarrow (Y, B)$$

such that $F(x, 0) = f(x)$ and $F(x, 1) = g(x)$. Note that this says that in continuously deforming f into g , it is required that at each stage we map A into B .

2.10 Theorem. *If $f, g: (X, A) \rightarrow (Y, B)$ are homotopic as maps of pairs, then $f_* = g_*$ as homomorphisms from $H_*(X, A)$ to $H_*(Y, B)$.*

Proof. As before define $i_0, i_1: (X, A) \rightarrow (X \times I, A \times I)$ by $i_0(x) = (x, 0)$ and $i_1(x) = (x, 1)$ and note that it is sufficient to show that $i_{0\#}$ and $i_{1\#}$ are chain homotopic.

Using the same technique as for the absolute case of Theorem 1.10 we construct a natural homomorphism

$$T: S_n(X) \rightarrow S_{n+1}(X \times I)$$

having

$$\partial T + T\partial = i_{0\#} - i_{1\#}$$

and observe that the restriction of T has $T(S_n(A)) \subseteq S_{n+1}(A \times I)$. Thus, there is induced the desired chain homotopy

$$T: S_n(X, A) \rightarrow S_{n+1}(X \times I, A \times I). \quad \square$$

EXAMPLE. To illustrate the difference between maps being absolutely homotopic and homotopic as maps of pairs, consider the following example. Let $X = [0, 1]$, $A = \{0, 1\}$, and $Y = S^1$, $B = \{1\}$. Define

$$g, f: X \rightarrow Y$$

by $f(x) = e^{2\pi i x}$ and $g(x) = 1$. Then f and g are maps of pairs $(X, A) \rightarrow (Y, B)$ and f and g are absolutely homotopic as maps from X to Y but they are not homotopic as maps of pairs.

EXERCISE 4. (The five lemma) Suppose that

$$\begin{array}{ccccccccc} C_1 & \xrightarrow{\alpha_1} & C_2 & \xrightarrow{\alpha_2} & C_3 & \xrightarrow{\alpha_3} & C_4 & \xrightarrow{\alpha_4} & C_5 \\ \downarrow f_1 & & \downarrow f_2 & & \downarrow f_3 & & \downarrow f_4 & & \downarrow f_5 \\ D_1 & \xrightarrow{\beta_1} & D_2 & \xrightarrow{\beta_2} & D_3 & \xrightarrow{\beta_3} & D_4 & \xrightarrow{\beta_4} & D_5 \end{array}$$

is a diagram of abelian groups and homomorphisms in which the rows are exact and each square is commutative. Then show

- (i) if f_2, f_4 are epimorphisms and f_5 is a monomorphism, then f_3 is an epimorphism;
- (ii) if f_2, f_4 are monomorphisms and f_1 is an epimorphism, then f_3 is a monomorphism.

Note that, as a special case of this exercise, if $f_1, f_2, f_4,$ and f_5 are isomorphisms, then f_3 is an isomorphism.

As pointed out before it seems that those points of A which are not close to the complement of A in X (see Figure 2.3) make no contribution to the relative homology group of the pair (X, A) . This property is formally set forth in the following *excision* theorem.

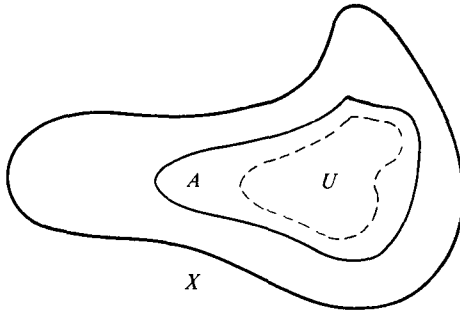

Figure 2.3

2.11 Theorem. *If (X, A) is a pair of spaces and U is a subset of A with \bar{U} contained in the interior of A , then the inclusion map*

$$i: (X - U, A - U) \rightarrow (X, A)$$

induces an isomorphism on relative homology groups

$$i_*: H_*(X - U, A - U) \rightarrow H_*(X, A).$$

That is, such a set U may be excised without altering the relative homology groups.

Proof. Denote by \mathcal{U} the covering of X given by the two sets $X - U$ and $\text{Int } A$. By assumption their interiors cover X ; thus, their interiors also cover A and we set \mathcal{U}' to be the covering of A given by $\{A - U, \text{Int } A\}$. Then by Theorem 1.14 the inclusion homomorphisms of chains

$$i: S_*^{\mathcal{U}}(X) \rightarrow S_*(X) \quad \text{and} \quad i': S_*^{\mathcal{U}'}(A) \rightarrow S_*(A)$$

both induce isomorphisms on homology.

Considering $S_*^{\mathcal{U}'}(A)$ as a subcomplex of $S_*^{\mathcal{U}}(X)$ there is a chain mapping of chain complexes

$$j: S_*^{\mathcal{U}}(X)/S_*^{\mathcal{U}'}(A) \rightarrow S_*(X)/S_*(A) = S_*(X, A).$$

The chain mappings i, i' , and j give rise to the following diagram of homology groups

$$\begin{array}{cccccccc} \cdots \rightarrow & H_n(S_*^{\mathcal{U}'}(A)) & \rightarrow & H_n(S_*^{\mathcal{U}}(X)) & \rightarrow & H_n(S_*^{\mathcal{U}}(X)/S_*^{\mathcal{U}'}(A)) & \rightarrow & H_{n-1}(S_*^{\mathcal{U}'}(A)) & \rightarrow \cdots \\ & \downarrow i' & & \downarrow i & & \downarrow j & & \downarrow i' & \\ \cdots \rightarrow & H_n(A) & \rightarrow & H_n(X) & \rightarrow & H_n(X, A) & \rightarrow & H_{n-1}(A) & \rightarrow \cdots \end{array}$$

Since i'_* and i_* are isomorphisms, it follows from the five lemma (see Exercise 4) that j_* is an isomorphism.

Now we can write $S_*^{\#}(X)$ as the sum of two subgroups

$$S_*^{\#}(X) = S_*(X - U) + S_*(\text{Int } A),$$

but not necessarily as a direct sum. Similarly

$$S_*^{\#'}(A) = S_*(A - U) + S_*(\text{Int } A).$$

Then by elementary group theory

$$S_*^{\#}(X)/S_*^{\#'}(A) \approx S_*(X - U)/S_*(A - U) = S_*(X - U, A - U).$$

Composing this isomorphism with the chain map j there is induced on homology the desired isomorphism

$$H_*(X - U, A - U) \rightarrow H_*(X, A). \quad \square$$

A short exact sequence of abelian groups and homomorphisms

$$0 \rightarrow A \xrightarrow{f} B \xrightarrow{g} C \rightarrow 0$$

is *split exact* if $f(A)$ is a direct summand of B .

EXERCISE 5. Suppose $0 \rightarrow A \xrightarrow{f} B \xrightarrow{g} C \rightarrow 0$ is short exact. Then the following are equivalent:

- (i) the sequence is split exact;
- (ii) there exists a homomorphism $\bar{f}: B \rightarrow A$ with $\bar{f} \circ f = \text{identity}$;
- (iii) there exists a homomorphism $\bar{g}: C \rightarrow B$ with $g \circ \bar{g} = \text{identity}$.

Let X be a space and y a single point. Denote by $\alpha: X \rightarrow y$ the map of X into y . Then there is the induced homomorphism on homology

$$\alpha_*: H_*(X) \rightarrow H_*(y).$$

Denote the kernel of α_* by $\tilde{H}_*(X)$. This subgroup of $H_*(X)$ is the *reduced homology group* of X . Note that since $H_i(y) = 0$ for $i \neq 0$, $\tilde{H}_i(X) = H_i(X)$ for $i \neq 0$. Furthermore, if $X \neq \emptyset$, then α_* is an epimorphism so that $\tilde{H}_0(X)$ is free abelian with one fewer basis element than $H_0(X)$. Note that if $f: X \rightarrow Y$ is a map, then $f_*: \tilde{H}_*(X) \rightarrow \tilde{H}_*(Y)$. For example, $\tilde{H}_*(S^n)$ is free abelian with one basis element in dimension n .

2.12 Proposition. *If $x_0 \in X$, then $H_*(X, x_0) \approx \tilde{H}_*(X)$.*

Proof. In the exact homology sequence of the pair (X, x_0) the homomorphism $H_i(x_0) \rightarrow H_i(X)$ is a monomorphism for each i . Thus, the long sequence breaks up into a collection of short exact sequences:

$$0 \rightarrow H_i(x_0) \xrightarrow{i_*} H_i(X) \xrightarrow{j_*} H_i(X, x_0) \rightarrow 0.$$

The map $\alpha: X \rightarrow x_0$ induces $\alpha_*: H_i(X) \rightarrow H_i(x_0)$ which splits the sequence. Thus there is a homomorphism $\beta: H_i(X, x_0) \rightarrow H_i(X)$ with $j_*\beta = \text{identity}$. This β is then an isomorphism onto the subgroup $\tilde{H}_i(X)$. \square

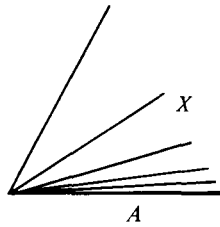

Figure 2.4

A subspace A of a space X is a *strong deformation retract* of X if there exists a map $F: X \times I \rightarrow X$ such that

- (i) $F(x, 0) = x$ for all $x \in X$;
- (ii) $F(x, 1) \in A$ for all $x \in X$;
- (iii) $F(a, t) = a$ for all $a \in A$ and $t \in I$.

EXERCISE 6. Let X be the space given by the unit interval together with a family of segments approaching it as pictured in Figure 2.4. If A is the unit interval, show that A is a deformation retract of X but not a strong deformation retract.

2.13 Proposition. Let (X, A) be a pair in which X is compact Hausdorff, A is closed in X and A is a strong deformation retract of X . Let $\pi: X \rightarrow X/A$ be the identification map and denote by y the point $\pi(A)$ in X/A . Then $\{y\}$ is a strong deformation retract of X/A .

Proof. Denote by $F: X \times I \rightarrow X$ the map given by the fact that A is a strong deformation retract of X . We must exhibit a map $\tilde{F}: (X/A) \times I \rightarrow X/A$ having $\tilde{F}(\tilde{x}, 0) = \tilde{x}$, $\tilde{F}(\tilde{x}, 1) = y$ for all $\tilde{x} \in X/A$ and $\tilde{F}(y, t) = y$ for all $t \in I$. Thus, it would be sufficient to define a map so that the following diagram is commutative:

$$\begin{array}{ccc}
 X \times I & \xrightarrow{F} & X \\
 \downarrow \pi \times \text{id} & & \downarrow \pi \\
 (X/A) \times I & \xrightarrow{\tilde{F}} & X/A
 \end{array}$$

So define $\tilde{F} = \pi \circ F \circ (\pi \times \text{id})^{-1}$. To see that this is single valued, let $(\tilde{x}, t) \in (X/A) \times I$. Then

$$(\pi \times \text{id})^{-1}(\tilde{x}, t)$$

is just (x, t) if $x \notin A$ and is $A \times \{t\}$ if $x \in A$. So if $x \notin A$, this is obviously single valued. If $x \in A$, note that $F(A \times \{t\}) \subseteq A$ and $\pi(A) = y$. Hence, \tilde{F} is single valued.

To show that \tilde{F} is continuous, let $C \subseteq X/A$ be a closed set. Then

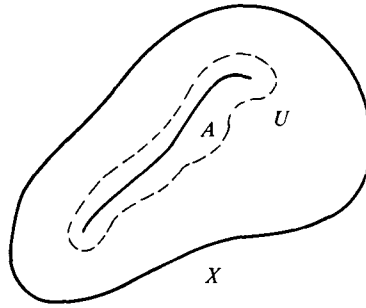

Figure 2.5

$F^{-1} \circ \pi^{-1}(C)$ is closed in $X \times I$, hence compact. Thus, $(\pi \times \text{id}) \circ F^{-1} \circ \pi^{-1}(C)$ is compact in $X/A \times I$, hence closed. Therefore, \tilde{F} is continuous. \square

2.14 Theorem. Let (X, A) be a pair with X compact Hausdorff and A closed in X , where A is a strong deformation retract of some closed neighborhood of A in X . Let $\pi: (X, A) \rightarrow (X/A, y)$ be the identification map. Then

$$\pi_*: H_*(X, A) \rightarrow H_*(X/A, y)$$

is an isomorphism.

Proof. Let U be a compact neighborhood of A in X which admits a strong deformation retraction onto A (see Figure 2.5). Applying Proposition 2.13 to the pair (U, A) we observe that $\{y\}$ is a strong deformation retract of $\pi(U)$. Thus, in the exact sequence of the triple $(X/A, \pi(U), y)$,

$$\cdots \rightarrow H_n(\pi(U), y) \rightarrow H_n(X/A, y) \rightarrow H_n(X/A, \pi(U)) \rightarrow H_{n-1}(\pi(U), y) \rightarrow \cdots$$

it follows that $H_*(\pi(U), y) = 0$. Hence, the inclusion map of pairs induces an isomorphism

$$H_*(X/A, y) \approx H_*(X/A, \pi(U)).$$

Recall that since X is compact Hausdorff, it is also normal. Now $\text{Int } U$ is an open set containing the closed set A , so there exists an open set V with $A \subseteq V$ and $\bar{V} \subseteq \text{Int } U$. Thus, V may be excised from the pair (X, U) to induce an isomorphism

$$H_*(X - V, U - V) \approx H_*(X, U).$$

Since A is a strong deformation retract of U , it follows from the exact sequence that

$$H_*(X, A) \approx H_*(X, U).$$

These two isomorphisms may be combined to give

$$H_*(X, A) \approx H_*(X - V, U - V).$$

In similar fashion the set $\pi(V)$ may be excised from the pair $(X/A, \pi(U))$ to give an isomorphism

$$H_*(X/A, y) \approx H_*(X/A, \pi(U)) \approx H_*(X/A - \pi(V), \pi(U) - \pi(V)).$$

Now note that since V is a neighborhood of the set A which was collapsed, the restriction of the map π gives a homeomorphism of pairs

$$\pi: (X - V, U - V) \rightarrow (X/A - \pi(V), \pi(U) - \pi(V)),$$

and so an isomorphism of their homology groups. All of these combine to give the desired isomorphism

$$H_*(X, A) \approx H_*(X/A, y). \quad \square$$

2.15 Corollary. *If (X, A) is a compact Hausdorff pair for which A is a strong deformation retract of some compact neighborhood of A in X , then*

$$H_*(X, A) \approx \tilde{H}_*(X/A). \quad \square$$

If $f: (X, A) \rightarrow (Y, B)$ is a map of pairs such that f maps $X - A$ one to one and onto $Y - B$, then f is a *relative homeomorphism*. Under certain conditions on the pairs a relative homeomorphism will induce an isomorphism of relative homology groups.

2.16 Theorem (Relative homeomorphism theorem). *If $f: (X, A) \rightarrow (Y, B)$ is a relative homeomorphism of compact Hausdorff pairs in which A is a strong deformation retract of some compact neighborhood in X and B is a strong deformation retract of some compact neighborhood in Y , then*

$$f_*: H_*(X, A) \rightarrow H_*(Y, B) \text{ is an isomorphism.}$$

Proof. Consider the diagram of spaces and maps, where π and π' are the identification maps and $f' = \pi' \circ f \circ \pi^{-1}$:

$$\begin{array}{ccc} X & \xrightarrow{f} & Y \\ \downarrow \pi & & \downarrow \pi' \\ X/A & \xrightarrow{f'} & Y/B \end{array}$$

As in the proof of Proposition 2.13 it is easy to see that f' is single valued and continuous. Since f is a relative homeomorphism, f' is one to one and onto. But X/A and Y/B are compact Hausdorff spaces, so f' is a homeomorphism.

Denoting $x_0 = \pi(A)$ and $y_0 = \pi'(B)$ there is the corresponding diagram of relative homology groups and induced homomorphisms:

$$\begin{array}{ccc}
 H_*(X, A) & \xrightarrow{f_*} & H_*(Y, B) \\
 \downarrow \pi_* & & \downarrow \pi'_* \\
 H_*(X/A, x_0) & \xrightarrow{f'_*} & H_*(Y/B, y_0)
 \end{array}$$

By Theorem 2.14 the homomorphisms π_* and π'_* are isomorphisms. Also f'_* is an isomorphism since f' is a homeomorphism. Thus

$$f_*: H_*(X, A) \rightarrow H_*(Y, B) \text{ is an isomorphism.} \quad \square$$

EXAMPLE. (1) There is a relative homeomorphism

$$f: (D^n, S^{n-1}) \rightarrow (S^n, z),$$

where z is any point in S^n . Both pairs satisfy the hypotheses of Theorem 2.16, so there is an isomorphism

$$f_*: H_*(D^n, S^{n-1}) \rightarrow H_*(S^n, z) \approx \tilde{H}_*(S^n).$$

(2) To see that the hypotheses of the theorem are actually necessary, consider the following example. Using the curve $\sin(1/x)$ construct a space as shown in Figure 2.6a, where X is the curve together with those points “inside,” and A is the boundary. Let $Y = D^2$ and $B = \partial D^2 = S^1$ (Figure 2.6b). Then (X, A) and (Y, B) are compact Hausdorff pairs. By flattening the pathological part of A it is possible to define a map of pairs $f: (X, A) \rightarrow (Y, B)$ which is a relative homeomorphism. However, it cannot induce an isomorphism on homology because $H_2(X, A) = 0$ and $H_2(Y, B) \approx \mathbb{Z}$. The result fails because A is not a strong deformation retract of some compact neighborhood of A in X .

The fact that $H_2(X, A) = 0$ is an easy consequence of the exact sequence of the pair (X, A) ,

$$\cdots \rightarrow H_2(A) \rightarrow H_2(X) \rightarrow H_2(X, A) \rightarrow H_1(A) \rightarrow \cdots$$

Now X is contractible, so $H_2(X) = 0$. On the other hand, if $\sum n_i \phi_i$ is a 1-chain in A , the sum must be finite. Since the curve A is not locally connected, the union of the images of these singular simplices cannot bridge the gap in

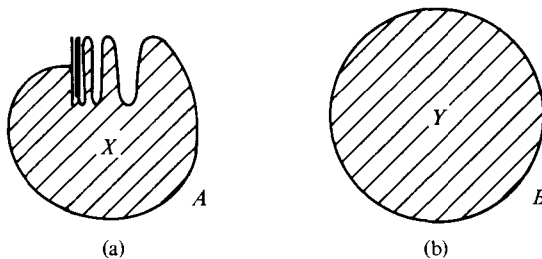

Figure 2.6

the $\sin(1/x)$ curve. Thus, the chain is supported by some contractible subset of A , so that if it is a cycle, it is also a boundary. Therefore, $H_1(A) = 0$ and by exactness $H_2(X, A) = 0$.

2.17 Lemma. *Let $f: S^{n-1} \rightarrow Y$ be a map, where Y is a compact Hausdorff space. If Y_f is the space obtained by attaching an n -cell to Y via f , then Y is a strong deformation retract of some compact neighborhood of Y in Y_f .*

Proof. Let $U \subseteq D^n$ be the subset given by $U = \{x \in D^n \mid \|x\| \geq \frac{1}{2}\}$, and observe that U is a compact neighborhood of S^{n-1} in D^n . Define a map $F: (U \cup Y) \times I \rightarrow U \cup Y$ by

$$F(x, t) = \begin{cases} x & \text{if } x \in Y \\ (1-t)x + t \cdot \frac{x}{\|x\|} & \text{if } x \in U. \end{cases}$$

Then F is continuous, $F(x, 0) = x$ and $F(x, 1) \in S^{n-1} \cup Y$ for all x , and if $x \in S^{n-1} \cup Y$, then $F(x, t) = x$ for all t . Thus, F is a strong deformation retraction of $U \cup Y$ onto $S^{n-1} \cup Y$.

Now let $\pi: D^n \cup Y \rightarrow Y_f$ be the identification map and consider the diagram

$$\begin{array}{ccc} (U \cup Y) \times I & \xrightarrow{F} & U \cup Y \\ \downarrow \pi \times \text{id} & & \downarrow \pi \\ \pi(U \cup Y) \times I & \xrightarrow{F'} & \pi(U \cup Y) \end{array}$$

As before define

$$F' = \pi \circ F \circ (\pi \times \text{id})^{-1}.$$

Then F' is well defined, continuous and gives a strong deformation retraction of the compact neighborhood $\pi(U \cup Y)$ of $\pi(Y)$ onto $\pi(Y)$. □

Note. Denote by h the composition

$$D^n \xrightarrow{\text{incl}} D^n \cup Y \xrightarrow{\pi} Y_f.$$

Then h gives a map of pairs $h: (D^n, S^{n-1}) \rightarrow (Y_f, Y)$, which is a relative homeomorphism. The hypotheses of Lemma 2.17 and Theorem 2.16 are satisfied, so we may conclude that

$$h_*: H_*(D^n, S^{n-1}) \rightarrow H_*(Y_f, Y)$$

is an isomorphism. Therefore, $H_*(Y_f, Y)$ is a free abelian group on one basis element of dimension n .

Suppose that D_1^n, \dots, D_k^n is a finite number of disjoint n -cells with boundaries $S_1^{n-1}, \dots, S_k^{n-1}$. For each $i = 1, \dots, k$ let $f_i: S_i^{n-1} \rightarrow Y$ be a map into a

fixed space Y . Define \sim to be the least equivalence relation on $D_1^n \cup \cdots \cup D_k^n \cup Y$ for which $x_i \sim f_i(x_i)$ whenever $x_i \in S_i^{n-1}$.

Then $D_1^n \cup \cdots \cup D_k^n \cup Y / \sim$ may be denoted Y_{f_1, \dots, f_k} , the space obtained by attaching n -cells to Y via f_1, \dots, f_k .

Conversely, if (X, Y) is a compact Hausdorff pair for which there exists a relative homeomorphism

$$F: (D_1^n \cup \cdots \cup D_k^n, S_1^{n-1} \cup \cdots \cup S_k^{n-1}) \rightarrow (X, Y),$$

then X is homeomorphic to Y_{f_1, \dots, f_k} where $f_i = F|_{S_i^{n-1}}$.

A *finite CW complex* is a compact Hausdorff space X and a sequence $X^0 \subseteq X^1 \subseteq \cdots \subseteq X^n = X$ of closed subspaces such that

- (i) X^0 is a finite set of points;
- (ii) X^k is homeomorphic to a space obtained by attaching a finite number of k -cells to X^{k-1} .

Note that $X^k - X^{k-1}$ is thus homeomorphic to a finite disjoint union of open k -cells, denoted $E_1^k, \dots, E_{r_k}^k$. These are the *k-cells* of X . Using the convention that $D^0 = \text{point}$ and $\partial D^0 = S^{-1} = \emptyset$, the requirements (i) and (ii) may be replaced by the condition that for each k there exist a relative homeomorphism

$$f: (D_1^k \cup \cdots \cup D_{r_k}^k, S_1^{k-1} \cup \cdots \cup S_{r_k}^{k-1}) \rightarrow (X^k, X^{k-1}).$$

It is easy to verify that the cells of X have the following properties:

- (a) $\{E_i^k | k = 0, 1, \dots, n; i = 1, \dots, r_k\}$ is a partition of X into disjoint sets;
- (b) for each k and i the set $\bar{E}_i^k - E_i^k$ is contained in the union of all cells of lower dimension;
- (c) $X^k = \bigcup_{k' \leq k} E_j^{k'}$;
- (d) for each i and k there exists a relative homeomorphism

$$h: (D^k, S^{k-1}) \rightarrow (\bar{E}_i^k, \bar{E}_i^k - E_i^k).$$

These properties characterize finite CW complexes and will be used as an alternate definition whenever it is convenient. The closed subset X^k is the *k-skeleton* of X . If $X^n = X$ and $X^{n-1} \neq X$, then X is *n-dimensional*.

EXAMPLE. It should be evident that for a given space there may be many different decompositions into cells and skeletons (see Figure 2.7). For example, let $X = S^2$. If z is a point in S^2 , then S^2 may be described as the space obtained by attaching a 2-cell to z . This gives S^2 a cell structure in which there is one 0-cell and one 2-cell (Figure 2.7a).

If z' is another point in S^2 and α is a simple path from z to z' , we have a cell structure with two 0-cells, a 1-cell, and a 2-cell (Figure 2.7b). Why was it necessary to include the 1-cell α when two vertices were used?

Further cells may be included as shown in the third figure, in which there

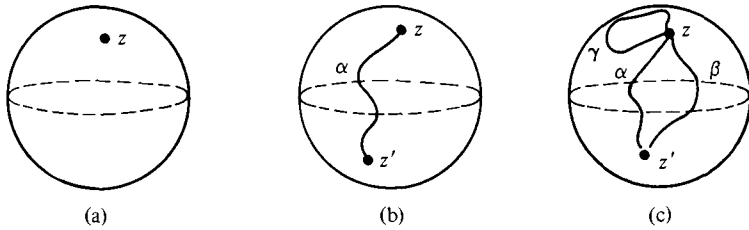

Figure 2.7

are two 0-cells, three 1-cells, and three 2-cells (Figure 2.7c). While there is considerable freedom in assigning a cell structure to a finite CW complex, it is apparent that any change in the number of cells in a certain dimension dictates some corresponding change in the number of cells in other dimensions.

Note that one apparent advantage CW complexes have over simplicial complexes is that considerably fewer cells are generally necessary in the decomposition of a complex.

2.18 Proposition. *If X and Y are finite CW complexes, then $X \times Y$ is a finite CW complex in a natural way.*

Proof. Suppose the cellular decompositions of X and Y are given by $\{E_i^k\}$ and $\{E_j^l\}$. The obvious candidate for a cellular decomposition for $X \times Y$ is the collection $\{E_i^k \times E_j^l\}$. First note that this is a partition of $X \times Y$ into a finite number of sets homeomorphic to open cells. Also

$$\begin{aligned} \overline{E_i^k \times E_j^l} - E_i^k \times E_j^l &= \overline{E_i^k} \times \overline{E_j^l} - E_i^k \times E_j^l \\ &= (\overline{E_i^k} - E_i^k) \times \overline{E_j^l} \cup \overline{E_i^k} \times (\overline{E_j^l} - E_j^l), \end{aligned}$$

which is contained in the union of all cells of dimension less than $k + l$.

To check the third requirement we may assume that there are relative homeomorphisms

$$f: (I^k, \partial I^k) \rightarrow (\overline{E_i^k}, \overline{E_i^k} - E_i^k) \quad \text{and} \quad g: (I^l, \partial I^l) \rightarrow (\overline{E_j^l}, \overline{E_j^l} - E_j^l).$$

Then $f \times g: (I^{k+l}, \partial I^{k+l}) \rightarrow (\overline{E_i^k \times E_j^l}, \overline{E_i^k \times E_j^l} - E_i^k \times E_j^l)$ gives the desired relative homeomorphism. \square

EXAMPLES. (1) Taking the decomposition of S^1 into one 0-cell (z) and one 1-cell (x) as in Figure 2.8a, the torus $S^1 \times S^1$ is naturally given the decomposition into one 0-cell ($z \times z$), two 1-cells ($z \times x$ and $x \times z$) and one 2-cell ($x \times x$) (Figure 2.8b).

(2) Recall that $\mathbb{R}P(0) = \text{pt}$ and $\mathbb{R}P(k)$ is obtained by attaching a k -cell to $\mathbb{R}P(k - 1)$. Thus, $\mathbb{R}P(n)$ is an n -dimensional finite CW complex with one cell

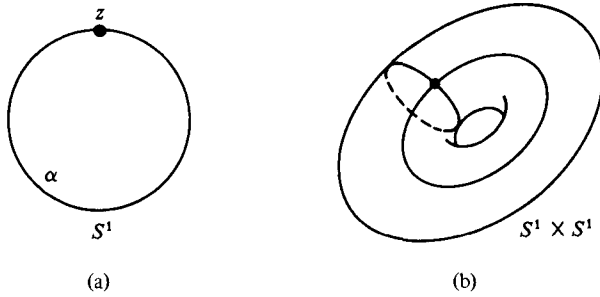

Figure 2.8

in each dimension $0, \dots, n$. Moreover, the k -skeleton of $\mathbb{R}P(n)$ under this structure is just $\mathbb{R}P(k)$.

(3) Similarly $\mathbb{C}P(n)$ is a finite CW complex of dimension $2n$ with one cell in each even dimension, $0, 2, 4, \dots, 2n$. Also $\mathbb{C}P(k) =$ the $2k$ -skeleton of $\mathbb{C}P(n) =$ the $(2k + 1)$ -skeleton of $\mathbb{C}P(n)$ for $0 \leq k \leq n$. An analogous structure may be given to quaternionic projective space.

If X is a finite CW complex with cells $\{E_i^k\}$, then a subset A of X is a *subcomplex* of X if whenever $A \cap E_i^k \neq \emptyset$ then $\bar{E}_i^k \subseteq A$. Note that if A is a subcomplex of X , then A is a closed subset of X and inherits a natural CW complex structure.

2.19 Theorem. *If A is a subcomplex of a finite CW complex X , then A is a strong deformation retract of some compact neighborhood of A in X .*

Proof. Denote by N the number of cells in $X - A$. We proceed by induction on N . If $N = 0$ the result is trivial and if $N = 1$ we may adapt the proof of Lemma 2.17 to give the desired result.

So suppose the result is true for any finite CW pair (Y, B) where the number of cells in $Y - B$ is $N - 1$. Let E_i^m be a cell of maximal dimension in $X - A$, and define $X_1 = X - E_i^m$. Note that X_1 must be a finite CW complex since any cell in $X - E_i^m$ either lies in A so that its boundary must also lie in A or has dimension less than or equal to m . In either case its boundary does not meet E_i^m . Moreover, A is a subcomplex of X_1 .

Now the number of cells in $X_1 - A$ is $N - 1$, so by the inductive hypothesis there exists a compact neighborhood U_1 of A in X_1 such that A is a strong deformation retract of U_1 .

There is a relative homeomorphism

$$\phi: (D^m, S^{m-1}) \rightarrow (\bar{E}_i^m, \bar{E}_i^m - E_i^m)$$

given by the structure of X as a finite CW complex (Figure 2.9). Define the radial projection map

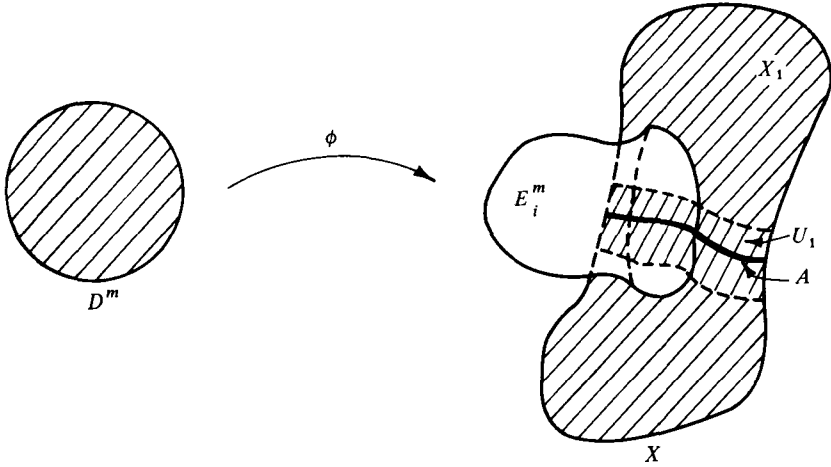

Figure 2.9

$$r: D^m - \{0\} \rightarrow S^{m-1}$$

by $r(x) = x/\|x\|$.

Since U_1 is a compact subset of X_1 , $\phi^{-1}(U_1)$ is a compact subset of S^{m-1} . Now define

$$V = \{\phi(x) \mid x \in D^m, \|x\| \geq \frac{1}{2} \text{ and } r(x) \in \phi^{-1}(U_1)\}.$$

Then V is a compact subset of X which admits a strong deformation retraction onto $U_1 \cap V$. Thus, $V \cup U_1$ is a compact subset of X which admits a strong deformation retraction onto A .

We must now make certain that the interior of $V \cup U_1$ contains A . Let y be in the interior of U_1 in X_1 . If y is not in V , y must also be in the interior of U_1 in X , hence also in the interior of $V \cup U_1$. So suppose y is in V or, in other words, y in $(\overline{E_i^m} - E_i^m)$. Now ϕ^{-1} of the interior of U_1 in X_1 is an open subset of S^{m-1} containing the compact set $\phi^{-1}(y)$. By the description of V it follows that $\phi^{-1}(y)$ is contained in the interior of $\phi^{-1}(V)$ in D^m . Thus, y must be in the interior of V in E_i^m .

Therefore, we have shown that any point in the interior of U_1 in X_1 lies in the interior of $V \cup U_1$ in X . So $V \cup U_1$ gives the desired compact neighborhood of A in X . □

Note that as an immediate consequence of this result, the conclusions in Theorem 2.14, Corollary 2.15, and the relative homeomorphism theorem, Theorem 2.16, will hold whenever the spaces involved are finite CW pairs. These have some very useful applications.

2.20 Proposition. *If X is a finite CW complex and X^k is the k -skeleton of X , then $H_j(X^k, X^{k-1}) = 0$ for $j \neq k$ and $H_k(X^k, X^{k-1})$ is a free abelian group with one basis element for each k -cell of X .*

Proof. X^{k-1} is a subcomplex of X^k , so by Theorem 2.19 it is a strong deformation retract of a compact neighborhood in X^k . Since X is a finite CW complex, there is a relative homeomorphism

$$\phi: (D_1^k \cup \cdots \cup D_r^k, S_1^{k-1} \cup \cdots \cup S_r^{k-1}) \rightarrow (X^k, X^{k-1}).$$

Then applying Theorem 2.16 yields the desired result from the corresponding fact about

$$H_*(D_1^k \cup \cdots \cup D_r^k, S_1^{k-1} \cup \cdots \cup S_r^{k-1}). \quad \square$$

For any finite CW complex X define

$$C_k(X) = H_k(X^k, X^{k-1}).$$

Then $C_*(X) = \sum C_k(X)$ is a graded group which is nonzero in only finitely many dimensions, moreover it is free abelian and finitely generated in each dimension. The connecting homomorphism of the triple (X^k, X^{k-1}, X^{k-2}) defines an operator

$$\partial: C_k(X) \rightarrow C_{k-1}(X).$$

Recall that these connecting homomorphisms may be factored in the following way:

$$\begin{array}{ccccc}
 & & & H_{k-2}(X^{k-2}) & \\
 & & & \nearrow \partial'' & \searrow j_* \\
 H_k(X^k, X^{k-1}) & \xrightarrow{\partial} & H_{k-1}(X^{k-1}, X^{k-2}) & \xrightarrow{\partial} & H_{k-2}(X^{k-2}, X^{k-3}), \\
 & \searrow \partial' & \nearrow i_* & & \\
 & & H_{k-1}(X^{k-1}) & &
 \end{array}$$

where ∂' and ∂'' are boundary operators for the respective pairs and i and j are inclusions of pairs. So $\partial \circ \partial = j_* \circ \partial'' \circ i_* \circ \partial'$. But $\partial'' \circ i_*$ is the composition of two consecutive homomorphisms in the exact sequence of the pair (X^{k-1}, X^{k-2}) and hence must be zero. Therefore, $\partial \circ \partial = 0$ and $\{C_*(X), \partial\}$ is a chain complex. Of course, the obvious question is then to ask how the homology of this chain complex is related to the singular homology of X .

2.21 Theorem. *If X is a finite CW complex, then*

$$H_k(C_*(X)) \approx H_k(X) \quad \text{for each } k.$$

Note: This is an extreme simplification. The chain complex used in defining $H_*(X)$ was, in general, a free abelian group with an uncountable basis. Here we have reduced the chain complex, not only to a finite basis, but these generators are in one-to-one correspondence with the cells of X .

Proof. We must analyze the composition

$$H_{k+1}(X^{k+1}, X^k) \xrightarrow{\partial_1} H_k(X^k, X^{k-1}) \xrightarrow{\partial_2} H_{k-1}(X^{k-1}, X^{k-2})$$

and show that $\text{kernel } \partial_2 / \text{image } \partial_1 \approx H_k(X)$.

First consider the diagram

$$\begin{array}{ccccccc}
 & & & & & & 0 \\
 & & & & & & \downarrow \\
 & & & & & & H_k(X^{k+1}, X^{k-2}) \\
 & & & & & & \downarrow j_* \\
 H_{k+1}(X^{k+1}, X^k) & \xrightarrow{\partial_1} & H_k(X^k, X^{k-1}) & \xrightarrow{i_*} & H_k(X^{k+1}, X^{k-1}) & \rightarrow & 0 \\
 & & \searrow \partial_2 & & \downarrow \partial_3 & & \\
 & & & & H_{k-1}(X^{k-1}, X^{k-2}) & &
 \end{array}$$

in which i_* and j_* are induced by inclusion maps of pairs. The row and the column are exact sequences of triples in which the zeros appear by Proposition 2.20. The triangle commutes by the naturality of the boundary operators.

Let $x \in \text{kernel } \partial_2$. Then $\partial_3 i_*(x) = 0$ and $i_*(x) = j_*(y)$ for some $y \in H_k(X^{k+1}, X^{k-2})$. Note that since j_* is a monomorphism, this y is uniquely determined. Thus, we define a homomorphism

$$\phi: \text{kernel } \partial_2 \rightarrow H_k(X^{k+1}, X^{k-2})$$

by $\phi(x) = y$.

If $y' \in H_k(X^{k+1}, X^{k-2})$ then $j_*(y')$ is in the image of i_* because i_* is an epimorphism. So there exists an $x' \in H_k(X^k, X^{k-1})$ with $i_*(x') = j_*(y')$. Then $\partial_2(x') = \partial_3 i_*(x') = \partial_3 j_*(y') = 0$ so x' is in the kernel of ∂_2 and $\phi(x') = y'$. We conclude that ϕ is an epimorphism.

Since $i_* \circ \partial_1 = 0$, it is apparent that the image of ∂_1 is contained in the kernel of ϕ . On the other hand, let $x \in \text{kernel } \partial_2$ with $\phi(x) = 0$. But the fact that j_* is a monomorphism implies that $i_*(x) = 0$. Then by exactness x is in the image of ∂_1 . Hence, we have shown that ϕ is an epimorphism with kernel given by the image of ∂_1 and we conclude that

$$\phi: \text{ker } \partial_2 / \text{im } \partial_1 \xrightarrow{\cong} H_k(X^{k+1}, X^{k-2}).$$

In the remainder of the proof we show that

$$H_k(X^{k+1}, X^{k-2}) \approx H_k(X).$$

Suppose that X is n -dimensional, so that

$$H_k(X) = H_k(X^n, X^{-1}).$$

Consider the sequence of homomorphisms

$$H_k(X) = H_k(X^n, X^{-1}) \rightarrow H_k(X^n, X^0) \rightarrow \cdots \rightarrow H_k(X^n, X^{k-2}),$$

each induced by an inclusion of pairs. In general, a homomorphism in this sequence is a part of the exact sequence of a triple

$$H_k(X^i, X^{i-1}) \rightarrow H_k(X^n, X^{i-1}) \rightarrow H_k(X^n, X^i) \xrightarrow{\Delta} H_{k-1}(X^i, X^{i-1}),$$

where $i \leq k - 2$. But by Proposition 2.20 for this range of values of i the first and last group must be zero. Hence, each homomorphism in the sequence is an isomorphism and

$$H_k(X) \approx H_k(X^n, X^{k-2}).$$

Similarly the homomorphisms

$$H_k(X^{k+1}, X^{k-2}) \rightarrow H_k(X^{k+2}, X^{k-2}) \rightarrow \cdots \rightarrow H_k(X^n, X^{k-2})$$

induced by inclusion maps are all isomorphism, so that

$$H_k(X^n, X^{k-2}) \approx H_k(X^{k+1}, X^{k-2})$$

and the proof is complete. \square

A map $f: X \rightarrow Y$ between finite CW complexes is *cellular* if $f(X^k) \subseteq Y^k$ for each integer k . If $f: X \rightarrow Y$ is cellular, then f defines a map of pairs

$$f: (X^k, X^{k-1}) \rightarrow (Y^k, Y^{k-1})$$

for each k , and hence a chain mapping

$$f_*: C_*(X) \rightarrow C_*(Y).$$

One should check that the homomorphism induced by f_* on the homology of the chain complex $C_*(X)$ corresponds with the homomorphism induced by f on $H_*(X)$ under the isomorphism of Theorem 2.21.

We now want to compute the homology of $\mathbb{R}P(n)$. To do this, give S^n the structure of a finite CW complex so that the k -skeleton is S^k . That is

$$S^0 \subseteq S^1 \subseteq \cdots \subseteq S^k \subseteq \cdots \subseteq S^n$$

so that there are two cells in each dimension, denoted by E_+^k and E_-^k . Similarly give $\mathbb{R}P(n)$ the structure of a finite CW complex so that $\mathbb{R}P(k)$ is the k -skeleton. Thus

$$\mathbb{R}P(0) \subseteq \mathbb{R}P(1) \subseteq \cdots \subseteq \mathbb{R}P(k) \subseteq \cdots \subseteq \mathbb{R}P(n)$$

and there is one cell in each dimension.

With these structures, the identification map $\pi: S^n \rightarrow \mathbb{R}P(n)$ is cellular. By Proposition 2.20 the group $C_k(\mathbb{R}P(n))$ is infinite cyclic for $0 \leq k \leq n$ and we denote a generator by e'_k . In order to compute the homology of $\mathbb{R}P(n)$ we need to know what the boundary operator $\partial: C_k(\mathbb{R}P(n)) \rightarrow C_{k-1}(\mathbb{R}P(n))$ does to the element e'_k .

To answer this question we first study the situation in S^n . Recall that the antipodal map of S^n , $A: S^n \rightarrow S^n$, is cellular and furthermore maps E_+^k homeomorphically onto E_-^k and vice versa for each k . Denote by F^k the composition of maps of pairs

$$(D^k, S^{k-1}) \xrightarrow{\approx} (\bar{E}_+^k, S^{k-1}) \xrightarrow{\text{incl}} (S^k, S^{k-1}).$$

If we choose a generator i_k of $H_k(D^k, S^{k-1})$, then $F_*^k(i_k) = e_k$ is a basis element in $H_k(S^k, S^{k-1}) = C_k(S^n)$. We view e_k as the basis element corresponding to the cell E_+^k . Since the following diagram commutes

$$\begin{array}{ccccc} (D^k, S^{k-1}) & \xrightarrow{\approx} & (\bar{E}_+^k, S^{k-1}) & \xrightarrow{\text{incl}} & (S^k, S^{k-1}) \\ & & \downarrow A & & \downarrow A \\ & & (\bar{E}_-^k, S^{k-1}) & \xrightarrow{\text{incl}} & (S^k, S^{k-1}) \end{array}$$

we may take the element $A_*(e_k)$ to be the basis element corresponding to the cell E_-^k . Thus, $C_k(S^n)$ is the free abelian group with basis $\{e_k, A_*(e_k)\}$.

To determine the boundary operator $\partial: C_k(S^n) \rightarrow C_{k-1}(S^n)$ consider the following diagram:

$$\begin{array}{ccccc} H_k(S^k, S^{k-1}) & & \xrightarrow{\partial} & & H_{k-1}(S^{k-1}, S^{k-2}) \\ & \searrow \partial' & & \nearrow i_* & \\ & & H_{k-1}(S^{k-1}) & & \\ & & \downarrow A_* & & \\ & & H_{k-1}(S^{k-1}) & & \\ & \nearrow \partial' & & \searrow i_* & \\ H_k(S^k, S^{k-1}) & & \xrightarrow{\partial} & & H_{k-1}(S^{k-1}, S^{k-2}) \end{array}$$

in which each triangle and rectangle is commutative. The homomorphism A_* in the center has been previously computed, specifically it is multiplication by $(-1)^k$. Starting with $e_k \in H_k(S^k, S^{k-1}) = C_k(S^n)$ we have

$$\begin{aligned}\partial A_{\star}(e_k) &= i_{\star}\partial' A_{\star}(e_k) = i_{\star}A_{\star}\partial'(e_k) \\ &= (-1)^k i_{\star}\partial'(e_k) = (-1)^k \partial(e_k).\end{aligned}$$

Thus, $e_k + (-1)^{k+1}A_{\star}(e_k)$ is a cycle in $C_k(S^n)$.

In fact, the set of cycles in $C_k(S^n)$ is an infinite cyclic subgroup generated by $e_k + (-1)^{k+1}A_{\star}(e_k)$. Before proceeding with the proof, note that this algebraic fact is entirely reasonable from a geometric viewpoint. Since e_k and $A_{\star}(e_k)$ correspond to the upper and lower halves of the sphere S^k , and they are being combined in such a way that the respective boundaries will cancel each other, geometrically we see this generating cycle as the sphere S^k itself. So suppose

$$\begin{aligned}0 &= \partial(n_1 e_k + n_2 A_{\star}(e_k)) \\ &= n_1 \partial e_k + n_2 \partial A_{\star} e_k \\ &= n_1 \partial e_k + (-1)^k n_2 \partial e_k \\ &= (n_1 + (-1)^k n_2) \partial e_k.\end{aligned}$$

Since $C_{k-1}(S^n)$ is free abelian, it must be true that either $\partial e_k = 0$ or $(n_1 + (-1)^k n_2) = 0$. Suppose $\partial e_k = 0$. Then also $\partial A_{\star} e_k = 0$ and $\partial: C_k(S^n) \rightarrow C_{k-1}(S^n)$ is identically zero. But we have observed that there are nontrivial cycles in $C_{k-1}(S^n)$, so if $k > 1$, these cycles must bound because $H_{k-1}(S^n) = 0$ in this range. [It is also easy to see that $\partial: C_1(S^n) \rightarrow C_0(S^n)$ cannot be identically zero because every element of $C_0(S^n)$ is a cycle.] This contradiction implies that $\partial e_k \neq 0$ and we conclude that $n_1 + (-1)^k n_2 = 0$ or $n_2 = (-1)^{k+1} n_1$. Therefore

$$n_1 e_k + n_2 A_{\star} e_k = n_1 (e_k + (-1)^{k+1} A_{\star} e_k)$$

as desired.

Since $H_k(S^n) = 0$ for $0 < k < n$, we must have

$$\partial(e_{k+1}) = \pm(e_k + (-1)^{k+1} A_{\star}(e_k)).$$

Once again, this formula may be shown to hold as well for $k = 0$. We may as well suppose the sign is $+$.

The identification map $\pi: (S^k, S^{k-1}) \rightarrow (\mathbb{R}P(k), \mathbb{R}P(k-1))$ is a relative homeomorphism on the closure of each k -cell. The generator e'_k could have been chosen so that $e'_k = \pi_{\star}(e_k)$. Then

$$\pi_{\star}(A_{\star} e_k) = (\pi \circ A)_{\star}(e_k) = \pi_{\star}(e_k) = e'_k.$$

Therefore, the boundary operator in the chain complex $C_{\star}(\mathbb{R}P(n))$ is given by

$$\begin{aligned}\partial(e'_{k+1}) &= \partial\pi_{\star}(e_{k+1}) = \pi_{\star}\partial(e_{k+1}) \\ &= \pi_{\star}(e_k + (-1)^{k+1} A_{\star} e_k) \\ &= e'_k + (-1)^{k+1} e'_k \\ &= \begin{cases} 2e'_k & \text{for } k \text{ odd} \\ 0 & \text{for } k \text{ even.} \end{cases}\end{aligned}$$

This completely determines the boundary operator in the chain complex $C_*(\mathbb{R}P(n))$ so that we may apply Theorem 2.21 to conclude the following:

2.22 Proposition. *The homology groups of real projective space are given by*

$$H_i(\mathbb{R}P(n)) \approx \begin{cases} \mathbb{Z} & \text{for } i = 0 \\ \mathbb{Z}_2 & \text{for } i \text{ odd, } 0 < i < n \\ \mathbb{Z} & \text{for } i \text{ odd, } i = n \\ 0 & \text{otherwise.} \end{cases} \quad \square$$

Recall that the *rank* of a finitely generated abelian group A is given by

$$\text{rank } A = \text{lub}\{n \mid \text{there exists a free abelian subgroup } B \subseteq A \text{ with basis having exactly } n \text{ elements}\}.$$

If A and B are isomorphic abelian groups, then $\text{rank } A = \text{rank } B$. If H is a subgroup of a finitely generated abelian group G , then

$$\text{rank } G/H = \text{rank } G - \text{rank } H.$$

2.23 Proposition. *If (X, A) is a finite CW pair, then $H_*(X, A)$ is a finitely generated abelian group.*

Proof. By Corollary 2.15 we know that $H_*(X, A) \approx \tilde{H}_*(X/A)$, and since $H_*(X/A) \approx \tilde{H}_*(X/A) \oplus \mathbb{Z}$, it is sufficient to show that $\tilde{H}_*(X/A)$ is finitely generated. X/A may be given the structure of a finite CW complex directly from the structure of X and A . The cells of X/A correspond to the cells of X which are not in A together with one 0-cell corresponding to A , thus $\dim(X/A) \leq \dim X$. It follows from Theorem 2.21 that $H_k(X/A)$ is the quotient of a finitely generated abelian group by a subgroup, and is nonzero for only finitely many values of k . Therefore, $H_*(X/A)$ is finitely generated and the result follows. \square

For a space X the i th *Betti number* of X , $b_i(X)$, is the rank of $H_i(X)$. From Proposition 2.23 we see that if X is a finite CW complex, $b_i(X)$ is finite for all i , and nonzero for only finitely many values of i . It was noted previously that $b_0(X)$ is the number of path components in X . In a corresponding sense the number $b_i(X)$ is a measure of a form of higher-dimensional connectivity of X . The *Euler characteristic* of X is given by

$$\chi(X) = \sum_i (-1)^i b_i(X).$$

2.24 Proposition. *If X is a finite CW complex with α_i cells in dimension i , then*

$$\sum (-1)^i \alpha_i = \chi(X).$$

Proof. Exercise 7. \square

EXERCISE 8. If X and Y are finite CW complexes, show that

$$\chi(X \times Y) = \chi(X) \cdot \chi(Y).$$

There are a number of important questions related to attaching cells, CW complexes, and maps that have not been addressed in this chapter. When examining the Hopf invariant in the context of products in Chapter 5, we will show that, if f_0 and f_1 are homotopic as maps of S^n into X , then the identity map of X extends to a homotopy equivalence between $X \cup_{f_0} D^{n+1}$ and $X \cup_{f_1} D^{n+1}$. A matter of broader significance is whether a mapping between finite CW complexes can be approximated by a cellular map. In this setting the word “approximation” refers to homotopy rather than the more traditional notion of distance in some metric. A proof of the following important result may be found in Brown [1988].

2.25 Theorem (Cellular Approximation Theorem). *If X and Y are finite CW complexes, A is a subcomplex of X , and $f: X \rightarrow Y$ is a map that is cellular on A , then f is homotopic to a cellular map via a homotopy that does not change the restriction of f to A . \square*

CHAPTER 3

The Eilenberg–Steenrod Axioms

Following the necessary algebraic preliminaries, we introduce the homology of a space with coefficients in an arbitrary abelian group. Combined with the results of the previous chapters this establishes the existence of homology theories satisfying the Eilenberg–Steenrod axioms for arbitrary coefficient groups. The corresponding uniqueness theorem is proved in the category of finite CW complexes. Finally, the singular cohomology groups are introduced and shown to satisfy the contravariant analogs of the axioms.

If A , B , and C are abelian groups, a mapping

$$\phi: A \times B \rightarrow C$$

is *bilinear* (or is a *bihomomorphism*) if

$$\phi(a_1 + a_2, b) = \phi(a_1, b) + \phi(a_2, b)$$

and

$$\phi(a, b_1 + b_2) = \phi(a, b_1) + \phi(a, b_2).$$

Note that if $A \times B$ is given the usual product group structure, ϕ will not be a homomorphism except in very special cases.

Denote by $F(A \times B)$ the free abelian group generated by $A \times B$. An element of $F(A \times B)$ has the form

$$\sum n_i(a_i, b_i),$$

where the sum is finite, $a_i \in A$, $b_i \in B$ and n_i is an integer. Let $R(A \times B)$ be the subgroup of $F(A \times B)$ generated by elements of the form

$$(a_1 + a_2, b) - (a_1, b) - (a_2, b)$$

or

$$(a, b_1 + b_2) - (a, b_1) - (a, b_2),$$

where $a, a_1, a_2 \in A$ and $b, b_1, b_2 \in B$. Then the *tensor product* of A and B is defined to be

$$A \otimes B = F(A \times B)/R(A \times B).$$

Note that if $\phi: A \times B \rightarrow C$ is any function, there exists a unique extension of ϕ to a homomorphism

$$\phi': F(A \times B) \rightarrow C.$$

Moreover, if ϕ is a bihomomorphism, then ϕ' is zero on the subgroup $R(A \times B)$, so that there is induced a homomorphism

$$\phi'': A \otimes B \rightarrow C,$$

which is uniquely determined by ϕ .

This universal property with respect to bilinear maps can be used to characterize the tensor product. There exists a bilinear map

$$\tau: A \times B \rightarrow A \otimes B$$

defined by taking (a, b) into $a \otimes b$, the coset containing (a, b) . Given a bihomomorphism $\phi: A \times B \rightarrow C$ we have seen that there exists a unique homomorphism $\phi'': A \otimes B \rightarrow C$ such that commutativity holds in

$$\begin{array}{ccc} A \times B & \xrightarrow{\phi} & C \\ & \searrow \tau & \nearrow \phi'' \\ & A \otimes B & \end{array}$$

On the other hand, if G is abelian and $\tau': A \times B \rightarrow G$ is a bihomomorphism whose image generates G , such that any bihomomorphism $\phi: A \times B \rightarrow C$ can be lifted through G , then G is isomorphic to $A \otimes B$.

Since the elements (a, b) generate $F(A \times B)$, it follows that the elements $a \otimes b$ generate $A \otimes B$. Note that in $A \otimes B$ we have

$$n(a \otimes b) = (na) \otimes b = a \otimes (nb) \quad \text{for any integer } n;$$

$$0 \otimes b = 0 = a \otimes 0 \quad \text{for all } a \text{ and } b;$$

$$\begin{aligned} (a_1 + a_2) \otimes (b_1 + b_2) &= (a_1 + a_2) \otimes b_1 + (a_1 + a_2) \otimes b_2 \\ &= a_1 \otimes b_1 + a_2 \otimes b_1 + a_1 \otimes b_2 + a_2 \otimes b_2. \end{aligned}$$

3.1 Proposition. *There is a unique isomorphism*

$$\theta: A \otimes B \approx B \otimes A$$

such that $\theta(a \otimes b) = (b \otimes a)$.

Proof. Define $\mu: A \times B \rightarrow B \otimes A$ by $\mu(a, b) = b \otimes a$. This is a well-defined bihomomorphism. Thus, there exists a unique homomorphism $\theta: A \otimes B \rightarrow B \otimes A$ with $\theta(a \otimes b) = b \otimes a$. Similarly there exists a homomorphism

$\theta': B \otimes A \rightarrow A \otimes B$ such that $\theta'(b \otimes a) = a \otimes b$. Then the compositions $\theta \circ \theta'$ and $\theta' \circ \theta$ are the identity on respective generating sets, and it follows that θ is an isomorphism with inverse θ' . \square

3.2 Proposition. *Given homomorphisms $f: A \rightarrow A'$ and $g: B \rightarrow B'$, there exists a unique homomorphism*

$$f \otimes g: A \otimes B \rightarrow A' \otimes B'$$

with

$$f \otimes g(a \otimes b) = f(a) \otimes g(b).$$

Proof. Define a mapping $\mu: A \times B \rightarrow A' \otimes B'$ by $\mu(a, b) = f(a) \otimes g(b)$, and observe that μ is well defined and bilinear. Thus, there exists a unique homomorphism $\theta: A \otimes B \rightarrow A' \otimes B'$ with $\theta(\tau(a, b)) = \mu(a, b)$ or $\theta(a \otimes b) = f(a) \otimes g(b)$. This θ is the desired $f \otimes g$. \square

3.3 Propositions. (a) *If $f: A \rightarrow A'$, $f': A' \rightarrow A''$ and $g: B \rightarrow B'$, $g': B' \rightarrow B''$, then*

$$(f' \circ f) \otimes (g' \circ g) = (f' \otimes g') \circ (f \otimes g);$$

(b) *If $A \approx \sum A_j$, then $A \otimes B \approx \sum (A_j \otimes B)$;*

(c) *if for each j in some index set J there is a homomorphism $f_j: A \rightarrow A'$ such that for any $a \in A$, $f_j(a)$ is nonzero for only finitely many values of j , then we can define $\sum f_j: A \rightarrow A'$. For any homomorphism $g: B \rightarrow B'$ it follows that*

$$(\sum f_j) \otimes g = \sum (f_j \otimes g);$$

(d) *for any abelian group A , $Z \otimes A \approx A$;*

(e) *if A is a free abelian group with basis $\{a_i\}$ and B is a free abelian group with basis $\{b_j\}$, then $A \otimes B$ is a free abelian group with basis $\{a_i \otimes b_j\}$.*

Proof. We prove only Part (d). Note that Part (e) follows from Parts (d) and (b) and Proposition 3.1.

Define $\mu: Z \times A \rightarrow A$ by $\mu(n, a) = na$. Then μ is bilinear, so there exists a unique lifting $\theta: Z \otimes A \rightarrow A$ with $\theta(n \otimes a) = n \cdot a$. Now define $\theta': A \rightarrow Z \otimes A$ by $\theta'(a) = 1 \otimes a$ and observe that

$$\theta\theta'(a) = \theta(1 \otimes a) = a$$

and

$$\theta'\theta(n \otimes a) = \theta'(na) = 1 \otimes na = n \otimes a.$$

Thus, θ and θ' behave as inverses on generating sets and θ is an isomorphism. \square

Now suppose that A' and B' are subgroups of A and B , respectively. We want to describe the tensor product $A/A' \otimes B/B'$. Denote by $\pi_1: A \rightarrow A/A'$ and $\pi_2: B \rightarrow B/B'$ the quotient homomorphisms. Then by Proposition 3.2

there is a homomorphism

$$\pi_1 \otimes \pi_2: A \otimes B \rightarrow A/A' \otimes B/B'.$$

If $a' \in A'$ and $b \in B$, then $\pi_1 \otimes \pi_2(a' \otimes b) = \pi_1(a') \otimes \pi_2(b) = 0$. Similarly if $a \in A$ and $b' \in B'$, $\pi_1 \otimes \pi_2(a \otimes b') = 0$. Thus, if we denote by

$$i_1: A' \rightarrow A \quad \text{and} \quad i_2: B' \rightarrow B,$$

the inclusion homomorphisms

$$H = \text{im}(i_1 \otimes \text{id}) + \text{im}(\text{id} \otimes i_2) \subseteq \ker \pi_1 \otimes \pi_2.$$

This means that $\pi_1 \otimes \pi_2$ induces a homomorphism

$$\Phi: A \otimes B/H \rightarrow A/A' \otimes B/B'.$$

We now want to show that Φ is an isomorphism. Define a function

$$\Psi: A/A' \times B/B' \rightarrow A \otimes B/H$$

by $\Psi(\{a\}, \{b\}) = \{a \otimes b\}$, where $\{ \}$ denotes the respective coset. It is evident that this is well defined, since if $a' \in A'$, then

$$\Psi(\{a'\}, \{b\}) = \{a' \otimes b\} = 0,$$

and similarly for $b' \in B'$. Ψ is also bilinear, so there exists a unique homomorphism

$$\theta: A/A' \otimes B/B' \rightarrow A \otimes B/H.$$

The homomorphisms Φ and θ are easily seen to be inverses of each other, so we have proved the following.

3.4 Proposition. *If $i_1: A' \rightarrow A$ and $i_2: B' \rightarrow B$ are inclusions of subgroups, then*

$$A/A' \otimes B/B' \approx \frac{A \otimes B}{\text{im}(i_1 \otimes \text{id}) + \text{im}(\text{id} \otimes i_2)}. \quad \square$$

EXAMPLE. $Z_p \otimes Z_q \approx Z_{(p,q)}$, where (p, q) is the greatest common divisor of p and q . To see this, let $(p, q) = r$ so that $p = r \cdot s$, $q = r \cdot t$ with $(s, t) = 1$. Denote by $pZ \subseteq Z$ the subgroup divisible by p and identify $Z_p = Z/pZ$ and $Z_q = Z/qZ$.

Therefore

$$\begin{aligned} Z_p \otimes Z_q &= Z/pZ \otimes Z/qZ \\ &\approx \frac{Z \otimes Z}{\text{im}(i_1 \otimes \text{id}) + \text{im}(\text{id} \otimes i_2)} \\ &\approx \frac{Z}{\text{im } i_1 + \text{im } i_2} \approx \frac{Z}{rsZ + rtZ} \approx Z/rZ \\ &= Z_r = Z_{(p,q)}. \end{aligned}$$

Specifically then

$$Z_2 \otimes Z_2 \approx Z_2, \quad Z_2 \otimes Z_3 = 0, \quad Z_6 \otimes Z_{15} \approx Z_3, \quad \text{and so forth.}$$

3.5 Proposition. *If $A \xrightarrow{\alpha} B \xrightarrow{\beta} C \rightarrow 0$ is an exact sequence, then for any abelian group D*

$$A \otimes D \xrightarrow{\alpha \otimes \text{id}} B \otimes D \xrightarrow{\beta \otimes \text{id}} C \otimes D \rightarrow 0$$

is exact.

Proof. Define a function

$$\phi: C \times D \rightarrow B \otimes D / \text{im}(\alpha \otimes \text{id})$$

as follows: for $(c, d) \in C \times D$ let $b \in B$ with $\beta(b) = c$. Then set

$$\phi(c, d) = \{b \otimes d\},$$

where $\{ \}$ denotes the coset in the quotient group. If b' is another element of B with $\beta(b') = c$, then $b - b' \in \text{kernel } \beta = \text{image } \alpha$, so there exists an $a \in A$ with $\alpha(a) = b - b'$. Then note that

$$\begin{aligned} \{b \otimes d\} - \{b' \otimes d\} &= \{(b - b') \otimes d\} \\ &= \{\alpha(a) \otimes d\} \\ &= \{(\alpha \otimes \text{id})(a \otimes d)\} \\ &= 0. \end{aligned}$$

This implies that ϕ is independent of the choice of b and so is well defined. Since ϕ is also bilinear, there is associated a unique homomorphism

$$\theta: C \otimes D \rightarrow \frac{B \otimes D}{\text{im}(\alpha \otimes \text{id})}.$$

On the other hand, $(\beta \otimes \text{id})$ is zero on the image of $(\alpha \otimes \text{id})$ so we have a homomorphism

$$\overline{\beta \otimes \text{id}}: B \otimes D / \text{im}(\alpha \otimes \text{id}) \rightarrow C \otimes D.$$

It is evident that $\overline{\beta \otimes \text{id}}$ and θ are inverses. This isomorphism establishes the desired exactness. \square

Note: If we had added a zero to the left of A in Proposition 3.5, the corresponding conclusion would not have been true. That is, in general, tensoring with D does not preserve monomorphisms. For example, let $\mu: Z \rightarrow Z$ be given by $\mu(n) = 2n$, so that μ is a monomorphism. However

$$\mu \otimes \text{id}: Z \otimes Z_2 \rightarrow Z \otimes Z_2$$

is zero because $(\mu \otimes \text{id})(1 \otimes 1) = (2 \otimes 1) = 1 \otimes 2 = 0$. For this reason we say that tensoring with D is a *right exact functor*. In trying to measure the extent

to which this fails to be left exact, we introduce a useful idea which will be employed in later results.

Recall that every abelian group A is the homomorphic image of a free abelian group and denote by F the free abelian group generated by the elements of A . Then let $\pi: F \rightarrow A$ be the natural epimorphism. If $R \subseteq F$ is the kernel of π , then R must be a free abelian group since it is a subgroup of F . (The proof that any subgroup of a free abelian group is free is definitely nontrivial. See Spanier's book for a proof of this fact.)

Thus, there is a short exact sequence

$$0 \rightarrow R \xrightarrow{i} F \xrightarrow{\pi} A \rightarrow 0.$$

This is an example of a *free resolution* of the group A . In general, a free resolution of an abelian group A is a short exact sequence

$$0 \rightarrow G_1 \xrightarrow{j} G_0 \xrightarrow{\tau} A \rightarrow 0$$

in which both G_1 and G_0 are free abelian groups. Given a free resolution of A and an abelian group D we know by Proposition 3.5 that exactness holds in

$$G_1 \otimes D \xrightarrow{j \otimes \text{id}} G_0 \otimes D \xrightarrow{\tau \otimes \text{id}} A \otimes D \rightarrow 0.$$

Then define $\text{Tor}(A, D) = \text{kernel}(j \otimes \text{id})$. In a sense, this measures the extent to which $j \otimes \text{id}$ fails to be a monomorphism.

EXERCISE 1. (a) Compute $\text{Tor}(Z_p, Z_q)$ for any integers p and q .

(b) Show that if A is free abelian, $\text{Tor}(B, A) = 0$ for any abelian group B .

(c) Show $\text{Tor}(A, B)$ is independent of the resolution chosen for A .

EXERCISE 2. Show that for any abelian groups A and B ,

$$\text{Tor}(A, B) \approx \text{Tor}(B, A).$$

Suppose that $C = \{C_n, \partial\}$ is a free chain complex. That is, each C_n is a free abelian group. For any abelian group G define a new chain complex $C \otimes G$ by

$$C \otimes G = \{C_n \otimes G, \partial \otimes \text{id}\}.$$

It is evident that $(\partial \otimes \text{id}) \circ (\partial \otimes \text{id}) = 0$.

If $f: C \rightarrow C'$ is a chain map, the associated homomorphism

$$f \otimes \text{id}: C \otimes G \rightarrow C' \otimes G$$

has

$$(f \otimes \text{id}) \circ (\partial \otimes \text{id}) = f \circ \partial \otimes \text{id} = \partial' \circ f \otimes \text{id} = (\partial' \otimes \text{id}) \circ (f \otimes \text{id})$$

so that $f \otimes \text{id}$ is also a chain map. Suppose T is a chain homotopy between chain maps f_0 and f_1 , that is,

$$\partial' T + T \partial = f_1 - f_0.$$

Then

$$\begin{aligned}
(\partial' \otimes \text{id})(T \otimes \text{id}) + (T \otimes \text{id})(\partial \otimes \text{id}) &= \partial' T \otimes \text{id} + T \partial \otimes \text{id} \\
&= (\partial' T + T \partial) \otimes \text{id} \\
&= (f_1 - f_0) \otimes \text{id} \\
&= f_1 \otimes \text{id} - f_0 \otimes \text{id}.
\end{aligned}$$

Hence, $T \otimes \text{id}$ is a chain homotopy between the chain maps $f_1 \otimes \text{id}$ and $f_0 \otimes \text{id}$.

Now fix the abelian group G . For each pair of spaces (X, A) we may use the free chain complex $S_*(X, A)$ to construct a new chain complex $S_*(X, A) \otimes G$. This chain complex, denoted $S_*(X, A; G)$, is the *singular chain complex of (X, A) with coefficients in G* . Since there is a natural isomorphism

$$S_*(X, A) \otimes Z \approx S_*(X, A),$$

we refer to $S_*(X, A)$ as the singular chain complex with *integral coefficients*. The homology of $S_*(X, A; G)$ is denoted by $H_*(X, A; G)$. Note that if $f: (X, A) \rightarrow (X', A')$ is a map of pairs, it follows from the preceding comments that there is an induced homomorphism

$$f_*: H_*(X, A; G) \rightarrow H_*(X', A'; G).$$

In some applications it is desirable to have additional structures on these homology groups. For example suppose that R is an associative ring and G is a right R -module. Then $S_n(X, A; G)$ may easily be given the structure of a right R -module in such a way that the boundary operators and induced homomorphisms are all homomorphisms of R -modules. In particular, if R is a field, then each $H_n(X, A; G)$ is a vector space over R . Note that for any R we know that R is a free module over itself, so that $S_n(X, A; R)$ is the free R -module generated by the singular n -simplices of $X \bmod A$.

Suppose that (X, A, B) is a triple of spaces. We have observed previously that there is a short exact sequence of chain maps

$$0 \rightarrow S_*(A, B) \rightarrow S_*(X, B) \rightarrow S_*(X, A) \rightarrow 0.$$

Since each chain complex is free, it follows from Exercises 1 and 2 that the exactness is preserved when we tensor throughout with G . Thus

$$0 \rightarrow S_*(A, B; G) \rightarrow S_*(X, B; G) \rightarrow S_*(X, A; G) \rightarrow 0$$

is a short exact sequence of chain complexes and chain maps. There results the long exact sequence of the triple (X, A, B) for homology with coefficients in G .

As in the case of integral coefficients it is easy to show that

$$H_n(\text{pt}; G) \approx \begin{cases} G & \text{for } n = 0 \\ 0 & \text{otherwise.} \end{cases}$$

Returning to the general case of a free chain complex C , we now consider the problem of relating the homology of $C \otimes G$ to the homology of C . For

example, suppose that $x \in C_n$ such that px is a boundary for some integer p . Since C is free, this implies that x must be a cycle, so x represents a homology class of order p . Let $b \in C_{n+1}$ with $\partial b = px$. Note that b is not a cycle unless $x = 0$. If we now tensor C with $G = Z_p$, the element $b \otimes 1$ in $C_{n+1} \otimes Z_p$ has

$$(\partial \otimes \text{id})(b \otimes 1) = \partial b \otimes 1 = px \otimes 1 = x \otimes p = 0.$$

Thus, $b \otimes 1$ is a cycle in $C_{n+1} \otimes Z_p$, where b had not been a cycle previously. In this way we see how torsion common to $H_n(C)$ and G produces new homology classes in $H_{n+1}(C \otimes G)$.

Before proceeding we note the easily proved algebraic fact that if $f: G \rightarrow G'$ and $g: G' \rightarrow G$ are homomorphisms of abelian groups with $g \circ f = \text{identity}$, then

$$G' = \text{im } f \oplus \text{ker } g.$$

As usual we denote by $B_n \subseteq Z_n \subseteq C_n$ the subgroups of boundaries and cycles, respectively. If C is a free chain complex, then each B_n and Z_n will be a free abelian group. Fix an abelian group G and consider the short exact sequence

$$0 \rightarrow Z_n \rightarrow C_n \xrightleftharpoons[\gamma]{\partial} B_{n-1} \rightarrow 0.$$

First note that since B_{n-1} is free, the sequence splits. That is, if $\{x_i\}$ is a basis for B_{n-1} , for each i there exists an element $c_i \in C_n$ with $\partial c_i = x_i$. Define $\gamma(x_i) = c_i$ and note that γ extends uniquely to a homomorphism which splits the sequence.

Now since B_{n-1} is free, $\text{Tor}(B_{n-1}, G) = 0$ and the short exact sequence is preserved when tensored with G ,

$$0 \rightarrow Z_n \otimes G \rightarrow C_n \otimes G \xrightleftharpoons[\gamma \otimes \text{id}]{\partial \otimes \text{id}} B_{n-1} \otimes G \rightarrow 0.$$

This sequence is also split by the homomorphism $\gamma \otimes \text{id}$.

On the other hand, the short exact sequence

$$0 \rightarrow B_n \xrightarrow{j} Z_n \rightarrow H_n(C) \rightarrow 0$$

is a free resolution of $H_n(C)$; hence, it yields the exact sequence

$$0 \rightarrow \text{Tor}(H_n(C), G) \xrightarrow{g} B_n \otimes G \xrightarrow{j \otimes \text{id}} Z_n \otimes G \rightarrow H_n(C) \otimes G \rightarrow 0.$$

We want to compute the homology of $C \otimes G$, given by kernel $\partial \otimes \text{id}$ /image $\partial_1 \otimes \text{id}$ in the following diagram:

$$\begin{array}{ccccc}
 B_n \otimes G & \xrightarrow{j \otimes \text{id}} & Z_n \otimes G & & \\
 \delta_3 \otimes \text{id} \uparrow & & \downarrow k \otimes \text{id} & & \\
 C_{n+1} \otimes G & \xrightarrow{\delta_1 \otimes \text{id}} & C_n \otimes G & \xrightarrow{\partial \otimes \text{id}} & C_{n-1} \otimes G \\
 & & \searrow \delta_2 \otimes \text{id} & & \nearrow i \otimes \text{id} \\
 & & Z_{n-1} \otimes G & &
 \end{array}$$

Note that by the above remarks both $i \otimes \text{id}$ and $k \otimes \text{id}$ are monomorphisms and $\partial_3 \otimes \text{id}$ is an epimorphism. Thus, $\ker \partial \otimes \text{id} = \ker \partial_2 \otimes \text{id}$ and image $\hat{c}_1 \otimes \text{id}$ may be identified with image $j \otimes \text{id}$.

Now consider the groups and homomorphisms

$$\begin{array}{ccccccc}
 0 \rightarrow \text{Tor}(H_{n-1}(C), G) & \xrightarrow{g} & B_{n-1} \otimes G & \xrightarrow{j \otimes \text{id}} & Z_{n-1} \otimes G & \rightarrow & H_{n-1}(C) \otimes G \rightarrow 0 \\
 & & \uparrow \hat{c}_3 \otimes \text{id} & & \downarrow \gamma \otimes \text{id} & & \\
 & & C_n \otimes G & & & &
 \end{array}$$

where the horizontal row is exact. As we have observed, the cycle group in $C_n \otimes G$ is the kernel of $(j \otimes \text{id}) \circ (\hat{c}_3 \otimes \text{id})$. Since $\hat{c}_3 \otimes \text{id}$ is an epimorphism and $\ker j \otimes \text{id} = \text{image } g$, we have

$$\ker(j \otimes \text{id}) \circ (\hat{c}_3 \otimes \text{id}) = (\hat{c}_3 \otimes \text{id})^{-1}(g(\text{Tor}(H_{n-1}(C), G))).$$

Thus, there are homomorphisms

$$(\hat{c}_3 \otimes \text{id})^{-1}g(\text{Tor}(H_{n-1}(C), G)) \xrightleftharpoons[\gamma \otimes \text{id}]{\hat{c}_3 \otimes \text{id}} g(\text{Tor}(H_{n-1}(C), G))$$

for which the composition $(\hat{c}_3 \otimes \text{id}) \circ (\gamma \otimes \text{id})$ is the identity. Combining these observations we have the cycle group expressed as a direct sum

$$\ker(j \otimes \text{id}) \circ (\hat{c}_3 \otimes \text{id}) = \ker(\hat{c}_3 \otimes \text{id}) \oplus (\gamma \otimes \text{id})g(\text{Tor}(H_{n-1}(C), G)).$$

Note that the first direct summand may be identified with $Z_n \otimes G$, while in the second, both g and $\gamma \otimes \text{id}$ are monomorphisms. Thus, we may identify the groups of cycles in $C_n \otimes G$ with the direct sum

$$Z_n \otimes G \oplus \text{Tor}(H_{n-1}(C), G).$$

Furthermore, the group of boundaries, which has been identified with the image of

$$B_n \otimes G \rightarrow Z_n \otimes G,$$

is contained entirely in the first summand.

Finally, recalling the exactness of

$$B_n \otimes G \rightarrow Z_n \otimes G \rightarrow H_n(C) \otimes G \rightarrow 0,$$

we conclude that the homology of the chain complex $C \otimes G$ is given by $H_n(C \otimes G) \approx H_n(C) \otimes G \oplus \text{Tor}(H_{n-1}(C), G)$. This completes the proof of the *universal coefficient theorem*:

3.6 Theorem. *If C is a free chain complex and G is an abelian group, then*

$$H_n(C \otimes G) \approx H_n(C) \otimes G \oplus \text{Tor}(H_{n-1}(C), G). \quad \square$$

3.7 Corollary. *For any pair of spaces (X, A) ,*

$$H_n(X, A; G) \approx H_n(X, A) \otimes G \oplus \text{Tor}(H_{n-1}(X, A), G). \quad \square$$

EXAMPLE. Recall that the integral homology groups of real projective space are given by

$$H_k(\mathbb{R}P(n)) \approx \begin{cases} \mathbb{Z} & \text{for } k = 0 \text{ or for } k \text{ odd and } = n \\ \mathbb{Z}_2 & \text{for } k \text{ odd, } 0 < k < n \\ 0 & \text{otherwise.} \end{cases}$$

Applying Corollary 3.7 to compute $H_*(\mathbb{R}P(n); \mathbb{Z}_2)$ we first note that $\text{Tor}(\mathbb{Z}_2, \mathbb{Z}_2) \approx \mathbb{Z}_2$ and $\text{Tor}(\mathbb{Z}, \mathbb{Z}_2) = 0$ were results from an earlier exercise. We are thus able to conclude that

$$H_k(\mathbb{R}P(n); \mathbb{Z}_2) \approx \begin{cases} \mathbb{Z}_2 & \text{for } 0 \leq k \leq n \\ 0 & \text{otherwise,} \end{cases}$$

where $H_k(\mathbb{R}P(n); \mathbb{Z}_2)$ results from $H_k(\mathbb{R}P(n)) \otimes \mathbb{Z}_2$ for $k = 0$ or for k odd, $0 < k \leq n$, and $H_k(\mathbb{R}P(n); \mathbb{Z}_2)$ results from two-torsion in $H_{k-1}(\mathbb{R}P(n))$ for k even $0 < k \leq n$.

We are now in a position to characterize singular homology in terms of a set of axioms. Each of these axioms has been established previously as an intrinsic property of singular homology theory. Our main purpose here is to show that when restricted to a suitable category of spaces and maps, these axioms uniquely determine a homology theory. The formulation of the axioms and the proof of the uniqueness are due to Eilenberg and Steenrod [1952].

Suppose \mathcal{H} is a function assigning to each pair of spaces (X, A) and integer n an abelian group $\mathcal{H}_n(X, A)$, and to each map of pairs $f: (X, A) \rightarrow (Y, B)$ a homomorphism $f_*: \mathcal{H}_n(X, A) \rightarrow \mathcal{H}_n(Y, B)$. Suppose further that for each n there is a homomorphism $\partial: \mathcal{H}_n(X, A) \rightarrow \mathcal{H}_{n-1}(A)$. This operation gives a *homology theory* if the following axioms are satisfied:

- (1) if $\text{id}: (X, A) \rightarrow (X, A)$ is the identity map, then

$$\text{id}_*: \mathcal{H}_n(X, A) \rightarrow \mathcal{H}_n(X, A)$$

is the identity homomorphism;

- (2) if $f: (X, A) \rightarrow (X', A')$, $g: (X', A') \rightarrow (X'', A'')$ are maps of pairs, then

$$(g \circ f)_* = g_* \circ f_*;$$

- (3) if $f: (X, A) \rightarrow (Y, B)$ is a map of pairs, then

$$\partial \circ f_* = (f|_A)_* \circ \partial;$$

- (4) if $i: (A, \emptyset) \rightarrow (X, \emptyset)$ and $j: (X, \emptyset) \rightarrow (X, A)$ are inclusion maps, then the following sequence is exact:

$$\cdots \xrightarrow{\partial} \mathcal{H}_n(A) \xrightarrow{i_*} \mathcal{H}_n(X) \xrightarrow{j_*} \mathcal{H}_n(X, A) \xrightarrow{\partial} \mathcal{H}_{n-1}(A) \rightarrow \cdots;$$

- (5) if $f, g: (X, A) \rightarrow (Y, B)$ are homotopic as maps of pairs, then $f_* = g_*$ as homomorphisms;

(6) if (X, A) is a pair and $U \subseteq A$ has $\bar{U} \subseteq \text{Int } A$, then the inclusion map $i: (X - U, A - U) \rightarrow (X, A)$ has $i_*: \mathcal{H}_n(X - U, A - U) \rightarrow \mathcal{H}_n(X, A)$ an isomorphism;

(7) $\mathcal{H}_n(\text{pt}) = 0$ for $n \neq 0$ [$\mathcal{H}_0(\text{pt})$ is called the *coefficient group*].

3.8 Theorem (Existence). *Given any abelian group G , there exists a homology theory with coefficient group G .*

Proof. Let $\mathcal{H}_n(X, A) = H_n(X, A; G)$, singular homology with coefficients in G . Then each of the axioms has been proved previously. \square

3.9 Theorem (Uniqueness). *On the category of finite CW pairs and maps of pairs, homology theories are determined, up to isomorphism, by their coefficient groups. That is, if \mathcal{H}_* and \mathcal{H}'_* are homology theories and $h: \mathcal{H}_* \rightarrow \mathcal{H}'_*$ is a natural transformation (that is, it commutes with induced homomorphisms and boundary operators) such that $h: \mathcal{H}_0(\text{pt}) \rightarrow \mathcal{H}'_0(\text{pt})$ is an isomorphism, then $h: \mathcal{H}_n(X, A) \rightarrow \mathcal{H}'_n(X, A)$ is an isomorphism for each integer n and each finite CW pair (X, A) .*

Proof. First note that the proofs of Theorems 2.14 and 2.16 (the relative homeomorphism theorem) only require that singular homology theory satisfy these axioms. So the analogs of these results will hold for any homology theory.

Denote the zero-sphere S^0 as the union of two points $S^0 = x \cup y$, and consider the diagram

$$\begin{array}{ccc} \mathcal{H}_k(y) & \xrightarrow{i_*} & \mathcal{H}_k(x \cup y, x) \\ \downarrow h & & \downarrow h \\ \mathcal{H}'_k(y) & \xrightarrow{i_*} & \mathcal{H}'_k(x \cup y, x) \end{array}$$

which commutes by the naturality of h . The horizontal maps are excision maps, so both horizontal homomorphisms are isomorphisms by Axiom 6. Since the first vertical homomorphism is an isomorphism by the hypothesis, we conclude that

$$h: \mathcal{H}_k(S^0, x) \rightarrow \mathcal{H}'_k(S^0, x)$$

is an isomorphism for each k . Now consider the diagram

$$\begin{array}{ccccccccc} \mathcal{H}_{k+1}(S^0, x) & \xrightarrow{\hat{c}} & \mathcal{H}_k(x) & \longrightarrow & \mathcal{H}_k(S^0) & \longrightarrow & \mathcal{H}_k(S^0, x) & \longrightarrow & \mathcal{H}_{k-1}(x) \\ \approx \downarrow h & & \approx \downarrow h & & \downarrow h & & \approx \downarrow h & & \approx \downarrow h \\ \mathcal{H}'_{k+1}(S^0, x) & \xrightarrow{\hat{c}} & \mathcal{H}'_k(x) & \longrightarrow & \mathcal{H}'_k(S^0) & \longrightarrow & \mathcal{H}'_k(S^0, x) & \longrightarrow & \mathcal{H}'_{k-1}(x) \end{array}$$

where the rows are exact by Axiom 4. By the five lemma (Exercise 4, Chapter 2), $h: \mathcal{H}_k(S^0) \rightarrow \mathcal{H}'_k(S^0)$ is an isomorphism.

We now prove inductively that h is an isomorphism for spheres of all dimensions. Suppose $h: \mathcal{H}_k(S^{n-1}) \rightarrow \mathcal{H}'_k(S^{n-1})$ is an isomorphism, $n > 0$. The n -disk D^n has the homotopy type of a point, so by using Axiom 5 we have an isomorphism $h: \mathcal{H}_k(D^n) \rightarrow \mathcal{H}'_k(D^n)$. In the commutative diagram

$$\begin{array}{ccc} \mathcal{H}_k(D^n, S^{n-1}) & \xrightarrow{\pi_*} & \mathcal{H}_k(S^n, x) \\ \downarrow h & & \downarrow h \\ \mathcal{H}'_k(D^n, S^{n-1}) & \xrightarrow{\pi_*} & \mathcal{H}'_k(S^n, x) \end{array}$$

the horizontal homomorphisms are isomorphisms since they are induced by relative homeomorphisms, while the vertical homomorphism on the left is an isomorphism by the five lemma (Exercise 4, Chapter 2). So we conclude that $h: \mathcal{H}_k(S^n, x) \rightarrow \mathcal{H}'_k(S^n, x)$ is an isomorphism, and again apply the five lemma to see that $h: \mathcal{H}_k(S^n) \rightarrow \mathcal{H}'_k(S^n)$ is an isomorphism. This completes the inductive step.

We are now ready to prove the theorem by inducting on the number of cells in the finite CW complex, X . Of course the conclusion is true if X has only one cell, so suppose that h is an isomorphism for all complexes having less than m cells. Let X be a finite CW complex containing m cells. If $\dim X = n$, pick a specific n -cell of X and denote by A the complement of this top dimensional cell. Then A is a subcomplex of X having $m - 1$ cells and there is a relative homeomorphism

$$\pi: (D^n, S^{n-1}) \rightarrow (X, A).$$

In the commutative diagram

$$\begin{array}{ccc} \mathcal{H}_k(D^n, S^{n-1}) & \xrightarrow[\cong]{\pi_*} & \mathcal{H}_k(X, A) \\ \cong \downarrow h & & \downarrow h \\ \mathcal{H}'_k(D^n, S^{n-1}) & \xrightarrow[\cong]{\pi_*} & \mathcal{H}'_k(X, A) \end{array}$$

the horizontal homomorphisms are induced by relative homeomorphisms, so they are isomorphisms. The first vertical homomorphism is an isomorphism by the inductive argument above. Hence

$$h: \mathcal{H}_k(X, A) \rightarrow \mathcal{H}'_k(X, A)$$

is an isomorphism for each k . Finally, the five lemma together with the inductive hypothesis imply that

$$h: \mathcal{H}_k(X) \rightarrow \mathcal{H}'_k(X)$$

is an isomorphism. This establishes the theorem for any finite CW complex, and the similar result for pairs follows by another application of the five lemma. \square

Note: During recent years, many theories have been developed which satisfy all of the axioms except Axiom 7. These have been called “generalized homology theories” and include stable homotopy, various K -theories, and bordism theories. Some of these theories are able to detect invariants which cannot be detected by ordinary homology. As a result, problems have been solved by these techniques whose solutions in terms of singular homology were either extremely difficult or impossible. Certainly any thorough study of modern methods in algebraic topology should include a significant segment on generalized homology and cohomology theories.

We now want to introduce singular cohomology theory. If A and G are abelian groups, denote by $\text{Hom}(A, G)$ the abelian group of homomorphisms from A to G , where $(f + g)(a) = f(a) + g(a)$ for each a in A . If $\phi: A \rightarrow B$ is a homomorphism, there is an induced homomorphism

$$\phi^\#: \text{Hom}(B, G) \rightarrow \text{Hom}(A, G)$$

defined by $\phi^\#(f) = f \circ \phi$. Note that if $\psi: B \rightarrow C$ is a homomorphism, then $(\psi \circ \phi)^\# = \phi^\# \circ \psi^\#$.

For a chain complex $\{C_n, \partial\}$ and an abelian group G , define abelian groups

$$C^n = \text{Hom}(C_n, G).$$

Then the boundary operator $\partial: C_{n+1} \rightarrow C_n$ has

$$\partial^\#: C^n \rightarrow C^{n+1}$$

and the composition $\partial^\# \circ \partial^\# = (\partial \circ \partial)^\# = 0$. So this resembles a chain complex except that the indices are increased rather than decreased. This leads us to define a *cochain complex* to be a collection of abelian groups and homomorphisms $\{C^n, \delta\}$ where $\delta: C^n \rightarrow C^{n+1}$ and $\delta \circ \delta = 0$. The homomorphism δ is the *coboundary operator*.

Note that if $\{C^n, \delta\}$ is a cochain complex and we define $D_n = C^{-n}$ and $\partial = \delta: D_n \rightarrow D_{n-1}$, then $\{D_n, \partial\}$ becomes a chain complex. So the two notions are precisely dual to each other and the use of cochain complexes is mainly a convenience.

The basic definitions for chain complexes may be duplicated for cochain complexes. If $\{C^n, \delta\}$ and $\{D^n, \delta'\}$ are cochain complexes, a *cochain map* f of degree k is a collection of homomorphisms

$$f: C^n \rightarrow D^{n+k}$$

such that $f \circ \delta = \delta' \circ f$. Two cochain maps f and g of degree zero are *cochain homotopic* if there is a collection of homomorphisms

$$T: C^n \rightarrow D^{n-1}$$

such that $\delta'T + T\delta = f - g$. T is a *cochain homotopy*.

Note that if $\{C_n, \partial\}$ and $\{D_n, \partial'\}$ are chain complexes and $f, g: \{C_n, \partial\} \rightarrow$

$\{D_n, \partial'\}$ are chain homotopic chain maps, then for any abelian group G the cochain maps

$$f^\#, g^\#: \{\text{Hom}(D_n, G), \partial'^\#\} \rightarrow \{\text{Hom}(C_n, G), \partial^\#\}$$

are cochain homotopic.

Let $C = \{C^n, \delta\}$ be a cochain complex and define $Z^n(C) = \text{kernel } \delta: C^n \rightarrow C^{n+1}$, the group of n -cocycles, and $B^n(C) = \text{image } \delta: C^{n-1} \rightarrow C^n$, the group of n -coboundaries. The n th cohomology group of C is then the quotient group

$$H^n(C) = Z^n(C)/B^n(C).$$

If $A = \{A^n\}$, $B = \{B^n\}$, and $C = \{C^n\}$ are cochain complexes and

$$0 \rightarrow A \rightarrow B \rightarrow C \rightarrow 0$$

is a short exact sequence of cochain maps of degree zero, then there exists a long exact sequence of cohomology groups

$$\cdots \rightarrow H^n(A) \rightarrow H^n(B) \rightarrow H^n(C) \xrightarrow{\Delta} H^{n+1}(A) \rightarrow \cdots,$$

where the connecting homomorphism Δ is defined in a fashion analogous to the connecting homomorphism for homology.

Now let (X, A) be a pair of spaces and G be an abelian group. Define

$$S^n(X, A; G) = \text{Hom}(S_n(X, A), G)$$

as the n -dimensional cochain group of (X, A) with coefficients in G . Let

$$\delta: S^n(X, A; G) \rightarrow S^{n+1}(X, A; G)$$

be given by $\delta = \partial^\#$. This defines the singular cochain complex of (X, A) whose cohomology is the graded group

$$H^*(X, A; G)$$

as the singular cohomology group of (X, A) with coefficients in G . Each of the covariant properties of singular homology becomes a contravariant property of singular cohomology. In particular, if $f: (X, A) \rightarrow (Y, B)$ is a map of pairs, then there is induced a homomorphism

$$f^*: H^*(Y, B; G) \rightarrow H^*(X, A; G).$$

If $g: (Y, B) \rightarrow (W, C)$ is another map of pairs, then $(gf)^* = f^* \circ g^*$.

Let

$$0 \rightarrow F \xrightarrow{i} H \xrightarrow{\pi} K \rightarrow 0$$

be a short exact sequence of abelian groups and homomorphism which is split by a homomorphism $\gamma: H \rightarrow F$. If G is an abelian group and f is a nonzero element of $\text{Hom}(K, G)$, then $\pi^\#(f) = f \circ \pi$ is a nonzero element of $\text{Hom}(H, G)$ since π is an epimorphism. It is evident that $i^\# \circ \pi^\# = (\pi \circ i)^\# = 0$. On the other hand, let $h: H \rightarrow G$ be a homomorphism such that $i^\#(h) =$

$h \circ i = 0$. Since h is zero on the image of $i = \text{kernel of } \pi$, h may be factored through K . The resulting homomorphism $\bar{h}: K \rightarrow G$ will have $\pi^\#(\bar{h}) = h$. Thus, the kernel of $i^\#$ is equal to the image of $\pi^\#$.

Finally, since $\gamma \circ i$ is the identity on F , $(\gamma \circ i)^\#$ is the identity on $\text{Hom}(F, G)$. But this implies that $i^\#$ is an epimorphism. Therefore, we have completed the proof of the following.

3.10 Proposition. *If $0 \rightarrow F \xrightarrow{i} H \xrightarrow{\pi} K \rightarrow 0$ is a split exact sequence and G is an abelian group, then*

$$0 \rightarrow \text{Hom}(K, G) \xrightarrow{\pi^\#} \text{Hom}(H, G) \xrightarrow{i^\#} \text{Hom}(F, G) \rightarrow 0$$

is exact. □

For example, if (X, A) is a pair of spaces, the sequence

$$0 \rightarrow S_*(A) \rightarrow S_*(X) \rightarrow S_*(X, A) \rightarrow 0$$

is split exact since $S_*(X, A)$ is a free chain complex. Thus, by Proposition 3.10

$$0 \rightarrow S^*(X, A; G) \rightarrow S^*(X; G) \rightarrow S^*(A; G) \rightarrow 0$$

is a short exact sequence of cochain complexes and cochain maps. By the previous remarks, this produces a long exact sequence in singular cohomology,

$$\cdots \rightarrow H^n(X, A; G) \rightarrow H^n(X; G) \rightarrow H^n(A; G) \rightarrow H^{n+1}(X, A; G) \rightarrow \cdots$$

It is important to note the necessity of the hypothesis in Proposition 3.10 that the original sequence be split exact. For example, if $i: Z \rightarrow Z$ is the monomorphism given by $i(1) = 2$, then

$$i^\#: \text{Hom}(Z, Z_2) \rightarrow \text{Hom}(Z, Z_2)$$

is zero and thus fails to be an epimorphism. The other conclusions of exactness will hold in general since they were established without using the fact that the sequence was split. As in the case of the tensor product, this failure to preserve short exact sequences may be measured.

Let E be an abelian group and take a free resolution of E ,

$$0 \rightarrow R \xrightarrow{i} F \xrightarrow{\pi} E \rightarrow 0.$$

Then for any abelian group G the sequence

$$0 \rightarrow \text{Hom}(E, G) \xrightarrow{\pi^\#} \text{Hom}(F, G) \xrightarrow{i^\#} \text{Hom}(R, G)$$

is exact by the proof of Proposition 3.10. Define

$$\text{Ext}(E, G) = \text{coker } i^\# = \text{Hom}(R, G)/\text{im } i^\#.$$

The basic properties of Ext are dual to those of Tor and may be established in the following exercises:

EXERCISES 3. (a) If E is free abelian, $\text{Ext}(E, G) = 0$.

(b) $\text{Ext}(E, G)$ is independent of the choice of the resolution for E .

(c) $\text{Ext}(E, G)$ is contravariant in E and covariant in G ; that is, given homomorphisms $f: E \rightarrow E'$ and $h: G \rightarrow G'$ there are induced homomorphisms $f^*: \text{Ext}(E', G) \rightarrow \text{Ext}(E, G)$ and $h_*: \text{Ext}(E, G) \rightarrow \text{Ext}(E, G')$.

(d) If $0 \rightarrow A \xrightarrow{j} B \xrightarrow{k} C \rightarrow 0$ is a short exact sequence, then exactness holds in

$$0 \rightarrow \text{Hom}(C, G) \xrightarrow{k^*} \text{Hom}(B, G) \xrightarrow{j^*} \text{Hom}(A, G) \rightarrow \text{Ext}(C, G) \\ \xrightarrow{k_*} \text{Ext}(B, G) \xrightarrow{j_*} \text{Ext}(A, G) \rightarrow 0.$$

Since we have defined $S^n(X, A; G) = \text{Hom}(S_n(X, A), G)$, it is useful to adopt the following notation: if ϕ is in $S^n(X, A; G)$ and c is in $S_n(X, A)$, then the value of ϕ on c is the element of G denoted by $\langle \phi, c \rangle$. Note that this pairing is bilinear in the sense that

$$\langle \phi_1 + \phi_2, c \rangle = \langle \phi_1, c \rangle + \langle \phi_2, c \rangle$$

and

$$\langle \phi, c_1 + c_2 \rangle = \langle \phi, c_1 \rangle + \langle \phi, c_2 \rangle.$$

In particular, for any integer n we have $\langle \phi, nc \rangle = \langle n\phi, c \rangle$. Thus the pairing produces a homomorphism

$$S^n(X, A; G) \otimes S_n(X, A) \rightarrow G$$

for each n . This homomorphism will be studied in more detail in the next chapter.

In this notation the boundary and coboundary operators are adjoint; that is,

$$\langle \phi, \partial c \rangle = \langle \delta \phi, c \rangle.$$

(In a somewhat different setting this is called the fundamental theorem of calculus.) Furthermore, if $f: (X, A) \rightarrow (Y, B)$ is a map of pairs, $\phi \in S^n(Y, B; G)$ and $c \in S_n(X, A)$, then

$$\langle \phi, f_*(c) \rangle = \langle f^*(\phi), c \rangle.$$

The cochain $\phi \in S^n(X, A; G)$ is a cocycle if and only if

$$\langle \delta \phi, c' \rangle = 0 \quad \text{for all } c' \in S_{n+1}(X, A),$$

or equivalently, if

$$\langle \phi, \partial c' \rangle = 0.$$

Thus, ϕ is a cocycle if and only if ϕ annihilates $B_n(X, A)$.

On the other hand, suppose that $\phi = \delta \phi'$ is a coboundary, where $\phi' \in S^{n-1}(X, A; G)$. Then

$$\langle \phi, c \rangle = \langle \delta \phi', c \rangle = \langle \phi', \partial c \rangle$$

so that if ϕ is a coboundary, then ϕ annihilates $Z_n(X, A)$.

Now let $x \in H^n(X, A; G)$ be represented by a cocycle ϕ and $y \in H_n(X, A)$ be represented by a cycle c . Then we define a pairing

$$\langle \cdot, \cdot \rangle: H^n(X, A; G) \otimes H_n(X, A) \rightarrow G$$

by $\langle x, y \rangle = \langle \phi, c \rangle$. To see that this is well defined, let $\phi + \delta \phi'$ and $c + \partial c'$ be

other choices for representatives of x and y . Then

$$\begin{aligned} \langle \phi + \delta\phi', c + \partial c' \rangle &= \langle \phi, c \rangle + \langle \delta\phi', c + \partial c' \rangle + \langle \phi, \partial c' \rangle \\ &= \langle \phi, c \rangle + \langle \phi', \partial c + \partial\partial c' \rangle + \langle \delta\phi, c' \rangle \\ &= \langle \phi, c \rangle. \end{aligned}$$

This pairing is called the *Kronecker index* and may be viewed as a homomorphism

$$\alpha: H^n(X, A; G) \rightarrow \text{Hom}(H_n(X, A), G).$$

For example, consider the zero-dimensional cohomology of a space X . $S^0(X; G) = \text{Hom}(S_0(X), G)$ and $S_0(X)$ may be identified with the free abelian group generated by the points of X . Since any homomorphism defined on $S_0(X)$ is determined by its value on the basis, we may identify $S^0(X; G)$ with the set of all functions from X to G .

Of course, $B^0(X; G) = 0$, so the cohomology may be determined by identifying the group of 0-cocycles. Note that ϕ will be a 0-cocycle if and only if $\langle \delta\phi, c \rangle = \langle \phi, \partial c \rangle = 0$ for all c in $S_1(X)$. This will be true if and only if $\phi(\sigma(1)) = \phi(\sigma(0))$ for every path σ in X . Therefore, we have identified $H^0(X; G) = Z^0(X; G)$ with the set of all functions from X to G which are constant on the path components of X . From this description we have the following.

3.11 Proposition. *If X is a topological space and $\{X_\alpha\}_{\alpha \in \Lambda}$ is the decomposition of X into its path components, then*

$$H^0(X; G) \approx \prod_{\alpha \in \Lambda} G_\alpha,$$

the direct product of copies of G , one for each path component of X . □

There is a natural embedding of G in $H^0(X; G)$ defined by sending $g \in G$ into the function from X to G having constant value g . If p is a point and $\pi: X \rightarrow p$ is the map of X to p , then

$$\pi^*: H^0(p; G) \rightarrow H^0(X; G)$$

maps $H^0(p; G) \approx G$ isomorphically onto this embedded copy of G . As for the case of homology we define

$$\tilde{H}^*(X; G) = H^*(X; G)/\text{im } \pi^*,$$

the *reduced* cohomology group of X with coefficients in G .

Essentially all of the results we have established previously for homology carry over in dual form to cohomology. For example, we have the following.

3.12 Theorem. *Let (X, A) be a pair of spaces and $U \subseteq A$ a subset with $\bar{U} \subseteq \text{Int } A$. Then the inclusion map of pairs*

$$i: (X - U, A - U) \rightarrow (X, A)$$

induces an isomorphism

$$i^*: H^*(X, A; G) \rightarrow H^*(X - U, A - U; G).$$

Proof. We have observed that

$$i_{\#}: S_{\#}(X - U, A - U) \rightarrow S_{\#}(X, A)$$

induces an isomorphism on homology groups (Theorem 2.11). The following exercise implies that $i_{\#}$ is a chain homotopy equivalence. Thus,

$$i^{\#}: S^*(X, A; G) \rightarrow S^*(X - U, A - U; G)$$

is a cochain homotopy equivalence and i^* is an isomorphism. \square

EXERCISES 4. If $f: C \rightarrow D$ is a chain map of degree zero between free chain complexes, such that f induces an isomorphism of homology groups, then f is a chain homotopy equivalence. [Hint: Take the algebraic mapping cone C_f of f (see page 167). Use the fact that C_f has trivial homology to construct the homotopies.]

3.13 Theorem. If $f, g: (X, A) \rightarrow (Y, B)$ are homotopic as maps of pairs, then the induced homomorphisms

$$f^*, g^*: H^*(Y, B; G) \rightarrow H^*(X, A; G)$$

are equal.

Proof. We showed in Theorem 2.10 that

$$f_{\#}, g_{\#}: S_{\#}(X, A) \rightarrow S_{\#}(Y, B)$$

are chain homotopic. Therefore

$$f^{\#}, g^{\#}: S^*(Y, B; G) \rightarrow S^*(X, A; G)$$

are cochain homotopic, and it follows that $f^* = g^*$. \square

EXERCISES 5. Formulate and prove the Mayer-Vietoris sequence for singular cohomology.

EXERCISE 6. State the Eilenberg-Steenrod axioms for cohomology and prove the uniqueness theorem in the category of finite CW complexes.

EXAMPLE. We want to compute $H^*(S^n, x_0; G)$. First note that $H^k(S^0, x_0; G)$ is isomorphic by excision to

$$H^k(\text{pt}; G) \approx \begin{cases} G & \text{for } k = 0 \\ 0 & \text{otherwise.} \end{cases}$$

As usual (Figure 3.1) we decompose the n -sphere into its upper cap E_+^n and lower cap E_-^n with $x_0 \in S^{n-1} = E_+^n \cap E_-^n$. Let z be a point in the interior of E_-^n .

Note that since the inclusions $x_0 \rightarrow E_+^n$ and $x_0 \rightarrow E_-^n$ are homotopy equivalences, the relative cohomology groups $H^*(E_+^n, x_0; G)$ and $H^*(E_-^n, x_0; G)$ are both zero. Thus, in the exact cohomology sequence of the triple (S^n, E_-^n, x_0) we have an isomorphism

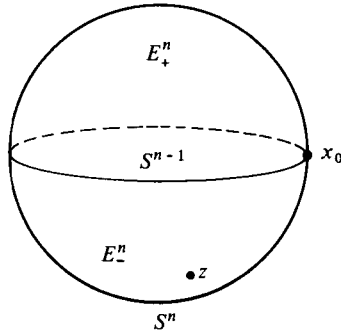

Figure 3.1

$$H^k(S^n, E_-^n; G) \xrightarrow{\cong} H^k(S^n, x_0; G).$$

The point z may be excised from the pair (S^n, E_-^n) to give an isomorphism

$$H^k(S^n, E_-^n; G) \xrightarrow{\cong} H^k(S^n - z, E_-^n - z; G).$$

Now the pair $(S^n - z, E_-^n - z)$ may be mapped by a relative homeomorphism to the pair (E_+^n, S^{n-1}) so that we have an isomorphism

$$H^k(S^n - z, E_-^n - z; G) \approx H^k(E_+^n, S^{n-1}; G).$$

Finally, the exact sequence of the triple (E_+^n, S^{n-1}, x_0) yields an isomorphism

$$H^{k-1}(S^{n-1}, x_0; G) \xrightarrow{\cong} H^k(E_+^n, S^{n-1}; G).$$

Thus

$$H^k(S^n, x_0; G) \approx H^{k-1}(S^{n-1}, x_0; G),$$

which completes the inductive step to prove that

$$H^k(S^n, x_0; G) \approx \begin{cases} G & \text{for } k = n \\ 0 & \text{otherwise.} \end{cases}$$

All of these similarities between homology and cohomology might lead one to ask: why bother? There may be many answers to this question; we briefly cite only three:

- (i) When the coefficient group is also a ring, the cohomology of a space may be given a natural ring structure. (This is not true for homology groups.) This additional algebraic structure gives us another topological invariant.
- (ii) Cohomology theory is the natural setting for “characteristic classes.” These are particular cohomology classes, arising in the study of fiber bundles, which have many applications, particularly to the topology of manifolds.

(iii) There are “cohomology operations,” naturally occurring transformations in cohomology theory, which have many applications in homotopy theory.

In Chapter 5 we will define the ring structure in (i) while studying the relationships between homology and cohomology theory. The topics in (ii) and (iii) are more advanced and will not be dealt with here. Perhaps the best source for topic (ii) is Milnor [1957]. The original source for topic (iii) is Steenrod and Epstein [1962]; see also the book by Mosher and Tangora [1968].

We close this chapter with an extension of the universal coefficient theorem which establishes the first basic connection between homology and cohomology groups.

3.14 Theorem. *Given a pair (X, A) of spaces and an abelian group G , there exists a split exact sequence*

$$0 \rightarrow \text{Ext}(H_{n-1}(X, A), G) \rightarrow H^n(X, A; G) \xrightarrow{\alpha} \text{Hom}(H_n(X, A), G) \rightarrow 0.$$

EXERCISE 7. Prove Theorem 3.14. □

CHAPTER 4

Covering Spaces

The concept of a covering space is a valuable source of examples, applications, and problems, as well as a basis for new ideas. Our analysis begins with an exploration of the lifting problem for a map into the base space. When the mapping is restricted to be a closed loop, the resulting structure is seen to be the fundamental group, and this provides a framework within which the lifting properties may be recast in algebraic terms. Continuing with this connection, the relations among the covering spaces over a given base are expressed in terms of the subgroups of the fundamental group of the base. The chapter closes with an examination of the relationship between the fundamental group and the first homology group and a discussion of Van Kampen's Theorem, a useful computational tool.

A space X is said to be *locally pathwise connected* if given any $x \in X$ and any open set U about x , there exists a pathwise connected V with $x \in \text{Int } V$ and $V \subseteq U$. Figures 2.4 and 2.6a give examples of spaces that are pathwise connected but not locally pathwise connected. For the remainder of this chapter the spaces considered will all be pathwise connected and locally pathwise connected, unless it is stated otherwise or apparent from the context.

If X is a topological space, a *covering space* of X is a space \tilde{X} and a continuous function $p: \tilde{X} \rightarrow X$ such that

- (a) p is onto, and
- (b) given any $x \in X$ there is a connected open set U about x such that p maps each component of $p^{-1}(U)$ homeomorphically onto U .

\tilde{X} is the *total space*, p is the *covering projection* or *covering map*, X is the *base space*, and U is a *fundamental neighborhood* of the covering.

EXAMPLES. (1) Consider S^1 as the complex numbers of modulus one, $S^1 = \{z \in \mathbb{C} \mid |z| = 1\}$. The function $\exp: \mathbb{R}^1 \rightarrow S^1$ given by $\exp(t) = e^{2\pi it}$ forms a covering space. Given any $x \in S^1$, a connected open set U about x that is properly contained in S^1 has $p^{-1}(U)$ a countable disjoint union of open intervals in \mathbb{R} , each mapped homeomorphically onto U by \exp (Figure 4.1).

(2) Recall from Chapter 2, the equivalence relation $x \sim -x$ on S^n gives rise to a quotient map $\pi: S^n \rightarrow \mathbb{R}P(n)$. This is a covering space in which a fundamental neighborhood U about x in $\mathbb{R}P(n)$ can be taken to be the image under π of an open disk V about a point of $\pi^{-1}(x)$ such that V is contained in an open hemisphere of S^n . V and $-V$ will then be the two components of $\pi^{-1}(U)$.

(3) One can view the torus T^2 as a quotient of \mathbb{R}^2 under the equivalence relation that sets $(x, y) \sim (x + m, y + n)$ for any $m, n \in \mathbb{Z}$. The quotient map

$$q: \mathbb{R}^2 \rightarrow T^2$$

maps each unit square in the plane onto the torus (Figure 4.2).

The image of the x -axis under q is homeomorphic to S^1 . For intuitive purposes we will call this the "horizontal" circle S_h in T^2 , and the orientation

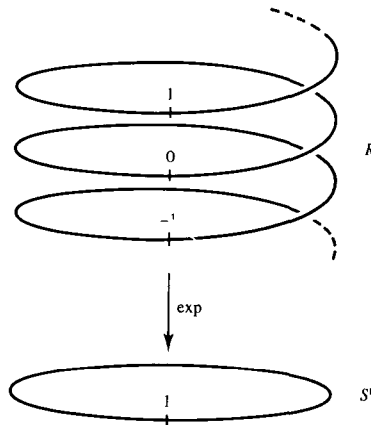

Figure 4.1

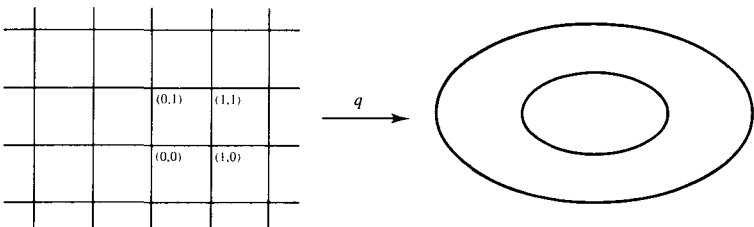

Figure 4.2

of the x -axis determines a “positive horizontal” direction around T^2 . Similarly, the image of the y -axis yields a “vertical” circle S_v in the torus and a “positive vertical” direction, once q has been specified. If we set $L = \{(x, y) \in \mathbb{R}^2 \mid x \text{ or } y \in \mathbb{Z}\}$ to be the lattice in \mathbb{R}^2 , then q maps L onto the union of these two circles, $S_h \vee S_v$, which intersect in a single point. Both $q: \mathbb{R}^2 \rightarrow T^2$ and $q|_L: L \rightarrow S_h \vee S_v$ are covering spaces.

EXERCISE 1. Explain why the following functions are *not* covering spaces:

- (a) $p: [-1, 1] \rightarrow [0, 1]$ by $p(x) = |x|$
- (b) $h: L \rightarrow S^1$ by $h(x, y) = e^{2\pi i(x+y)}$
- (c) $q: \mathbb{R}^2 - \{(0, 0)\} \rightarrow T^2$, the restriction of q to the punctured plane.

The strength of a covering space $p: \tilde{X} \rightarrow X$ lies in the facts that X and \tilde{X} are locally identical, and the preimages in \tilde{X} of fundamental neighborhoods in X are systematically combined to produce the space \tilde{X} . It is clear from the examples that the total space and the base space may be significantly different in a global sense.

Now let $p: \tilde{X} \rightarrow X$ be a covering space, and $f: Y \rightarrow X$ be a continuous function. A fundamental question that arises in many applications is the *lifting problem*: Does there exist a continuous function $g: Y \rightarrow \tilde{X}$ such that $pg = f$?

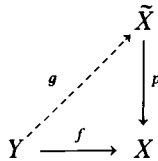

The local properties of the covering space provide some hope. Specifically, start with $y \in Y$, and consider $x = f(y) \in X$. Let U be a fundamental neighborhood of x , and select a component V of $p^{-1}(U) \subseteq \tilde{X}$. The continuity of f provides an open set W about y with $f(W) \subseteq U$. Since $p|_V: V \rightarrow U$ is a homeomorphism, the composition

$$(p|_V)^{-1}f|_W: W \rightarrow \tilde{X}$$

gives a lift of $f|_W$. In other words, there will always be a lifting on some open set about any given point of Y . However, the global structure of the spaces makes it clear that a lifting over all of Y need not exist.

EXERCISE 2. (a) Show that the function $f: S^1 \rightarrow S^1$ given by $f(z) = z^5$ cannot be lifted to \mathbb{R} in the covering space $\exp: \mathbb{R} \rightarrow S^1$.

(b) Show that the inclusion map $i: \mathbb{R}P(2) \rightarrow \mathbb{R}P(3)$ cannot be lifted to S^3 in the covering space $\pi: S^3 \rightarrow \mathbb{R}P(3)$.

(c) Show that the identity map $\text{id}: S_h \vee S_v \rightarrow S_h \vee S_v$ cannot be lifted to L in the covering space $q: L \rightarrow S_h \vee S_v$.

We now restrict Y to be a closed interval. For this simple case a lifting will always exist, and the analysis of the resulting properties will lead us to a new algebraic tool for solving topological problems.

4.1 Proposition. *If $p: \tilde{X} \rightarrow X$ is a covering space, and $f: [0, 1] \rightarrow X$ is a path in X , then there exists a lifting $g: [0, 1] \rightarrow \tilde{X}$ for p ; i.e., g is a continuous function and $pg = f$.*

Proof. The preceding discussion shows that if $z \in p^{-1}(f(0))$, then there is an open set W about $\{0\}$ and a lift g of $f|_W$ with $g(0) = z$. Moreover, once z is selected, and W is chosen so that its image under f lies in a fundamental neighborhood of $f(0)$, this lifting is uniquely determined.

Define $D = \{t \in [0, 1] \mid f: [0, t] \rightarrow X \text{ can be lifted to a path in } \tilde{X} \text{ beginning at } z\}$. Since W contains an interval about 0, D is nonempty. D is bounded above by 1, so let $d \in [0, 1]$ be the least upper bound of D . We will show that $d \in D$ and, in fact, $d = 1$.

Take a fundamental open set U' about $f(d)$ in X . Since f is continuous, there exists an open set W' about d with $f(W') \subseteq U'$. Furthermore, there is a point $z' \in W'$ with $0 < z' < d$ and $z' \in D$. The lifting of $f: [0, z'] \rightarrow X$ determines a point $g(z')$ in \tilde{X} , and this point in $p^{-1}(f(z'))$ together with the fundamental neighborhood U' permit a lifting of $f: [z', d] \rightarrow X$. Since these liftings agree at z' , they may be combined to produce a lifting over the entire interval $[0, d]$, establishing that $d \in D$.

Suppose $d < 1$. Then using the same W' , there would be point $z'' \in W'$ with $d < z'' < 1$. The same argument shows $z'' \in D$, and consequently that d is not the least upper bound of D , contradicting the original choice of d . Thus $d = 1$, $D = [0, 1]$, and the lifting exists. \square

It is clear from the above argument that once the initial point $f(0)$ is lifted, the remainder of the lift is uniquely determined. In fact, a more general proposition is true:

4.2 Proposition. *Let $p: \tilde{X} \rightarrow X$ be a covering space, and $f: Y \rightarrow X$ be a continuous function with Y connected. If $g_1, g_2: Y \rightarrow \tilde{X}$ are liftings of f with $g_1(y) = g_2(y)$ for some y in Y , then $g_1 \equiv g_2$.*

EXERCISE 3. Prove Proposition 4.2. \square

For a covering space $p: \tilde{X} \rightarrow X$, fix a point x_0 in the base space X , and consider paths in X that begin at x_0 , i.e., functions $f: [0, 1] \rightarrow X$ with $f(0) = x_0$. If \tilde{x}_0 is a selected element of $p^{-1}(x_0)$, there is unique lift of f to a path in \tilde{X} beginning at \tilde{x}_0 . Note that if the original path f in X is a loop, it need not be the case that the lift of f is a loop in \tilde{X} . In fact it is this variation in the

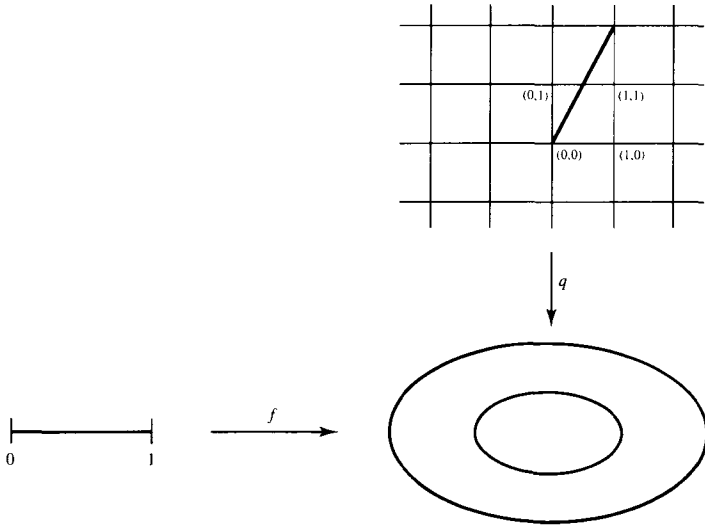

Figure 4.3

lifted path that carries information on the loop in the base, and through it, the topological properties of the base itself.

In the previous example (3), $q: \mathbb{R}^2 \rightarrow T^2$, let \tilde{x}_0 be the origin in \mathbb{R}^2 and $x_0 = q(\tilde{x}_0)$ in T^2 . Let f be the loop in T^2 that wraps once around the torus in the “positive horizontal” direction and twice around the torus in the “positive vertical” direction. This loop lifts to a path in \mathbb{R}^2 from $\tilde{x}_0 = (0, 0)$ to $(1, 2)$, another point in $q^{-1}(x_0)$ (Figure 4.3).

On the other hand, in example (2) consider $\mathbb{R}P(2)$ as S^1 with a 2-cell attached via a map of degree 2 from $\partial D^2 \rightarrow S^1$. What is the result of lifting the loop in $\mathbb{R}P(2)$ that wraps once around this 1-skeleton?

To understand this question, it helps to specify a pre-image of the 1-skeleton of $\mathbb{R}P(2)$ under the quotient map $S^2 \rightarrow \mathbb{R}P(2)$. One way to express it is as a closed semicircle at the equator; the equivalence relation identifies the two endpoints to produce the 1-skeleton. While $\mathbb{R}P(2)$ cannot be drawn as an imbedded surface in \mathbb{R}^3 , an open “collar” about the 1-skeleton can be expressed as a Möbius band $M \subseteq \mathbb{R}P(2)$, with the 1-skeleton along the midline. Under the quotient map, M arises from a collar extending above and below the semi-circle in S^2 ; the identification of x with $-x$ provides the twist on the ends of the collar to produce M (Figure 4.4).

In the expression of $\mathbb{R}P(2)$ as a 2-cell attached to S^1 , M arises as the image of an open collar along the boundary of D^2 . The map of degree 2 wraps ∂D^2 twice around the 1-skeleton, producing the entire band M . From this representation, it is clear that a loop traversing the 1-skeleton once lifts in S^2 to a path from \tilde{x}_0 to $-\tilde{x}_0$. Note that if the loop is repeated to produce a loop that

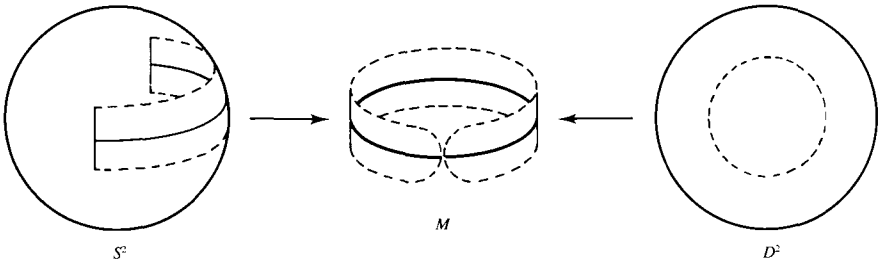

Figure 4.4

wraps twice around the 1-skeleton, then the lift becomes a loop with terminal point back at \tilde{x}_0 . This was not the case in the first example; repeating the loop in T^2 would lift to a path with endpoint $(2, 4)$, etc., and the lifts of successively composed loops in T^2 would never return to $\tilde{x}_0 = (0, 0)$.

EXERCISE 4. To prove the next proposition, it will be necessary to use the important concept of the Lebesgue number. If Y is a metric space and U is an open covering of Y , a *Lebesgue number* for U is a positive number μ such that any subset of Y with diameter less than μ is contained in some open set in U . Prove that if Y is a compact metric space and U is an open cover of Y , then U admits a Lebesgue number.

4.3 Proposition. *If $p: \tilde{X} \rightarrow X$ is a covering space and $F: I \times I \rightarrow X$ is a homotopy between paths f_0 and f_1 , then for any lift of $f_0(0) = F(0, 0)$ to a point in \tilde{X} , there is a unique lifting of the homotopy F to a homotopy $G: I \times I \rightarrow \tilde{X}$ between paths g_0 and g_1 which are lifts of f_0 and f_1 ; that is, $pG = F$.*

Proof. Using the continuity of F , there is about each (s, t) in $I \times I$ an open set U whose image under F is contained in a fundamental open set in X . The set of all such U forms an open cover of the compact set $I \times I$. Let μ be a Lebesgue number for this covering, and select points $0 = t_0 < t_1 < \dots < t_n = 1$ so that each rectangle $[t_i, t_{i+1}] \times [t_j, t_{j+1}]$ has diameter less than μ .

Now consider $[t_0, t_1] \times [t_0, t_1]$. Its image in X under F is contained in a fundamental open set. Thus the lift of $F(t_0, t_0) = F(0, 0)$ to \tilde{X} uniquely determines a lifting G on $[t_0, t_1] \times [t_0, t_1]$ into \tilde{X} . The rectangle $[t_0, t_1] \times [t_1, t_2]$ likewise is mapped by F into a fundamental open set. Along the edge $[t_0, t_1] \times \{t_1\}$ a lift G has already been defined. There exists a lift of F that agrees with G along this edge, and by 1.2, it must be unique.

Continuing in this manner, G may be extended to $[t_0, t_1] \times I$, then in the same manner to $[t_1, t_2] \times I$, always using the previous lifting along one or more edges of the small rectangle. The end result is a unique map

$$G: I \times I \rightarrow \tilde{X}$$

such that $G(0, 0)$ agrees with the lift of $F(0, 0)$ and $pG = F$. □

Note that if the homotopy F between the paths f_0 and f_1 keeps the initial and terminal points of the paths fixed, then the same must be true of G in \tilde{X} . In particular, for loops at x_0 there is the following corollary.

4.4 Corollary. *Let $p: \tilde{X} \rightarrow X$ be a covering space with $p(\tilde{x}_0) = x_0$ and f be a loop in X at x_0 . If g is the lift of f with initial point \tilde{x}_0 , the terminal point of g in $p^{-1}(x_0)$ is an invariant of the homotopy class of the loop f , under homotopies that keep the endpoints fixed. \square*

This relationship between based homotopy classes of loops at x_0 and the discrete set $p^{-1}(x_0)$ in \tilde{X} is very important. Assuming \tilde{X} is pathwise connected, for any point \tilde{w} in $p^{-1}(x_0)$, there is a path g in \tilde{X} from \tilde{x}_0 to \tilde{w} . Then pg is a loop at x_0 that clearly lifts to g . In other words, the correspondence

$$\{\text{based homotopy classes of loops at } x_0\} \rightarrow p^{-1}(x_0),$$

sending the class of f into the terminal point of the lift of f with initial point \tilde{x}_0 , has its image precisely the set of points in $p^{-1}(x_0)$ lying in the path component containing \tilde{x}_0 .

A natural question to ask is whether this correspondence is one-to-one. Suppose f and f' are loops at x_0 lifting to paths g and g' leading from \tilde{x}_0 to the same point \tilde{w} in $p^{-1}(x_0)$. Note that if there exists a homotopy G in \tilde{X} from g to g' , fixing the endpoints of the paths, then pG is a based homotopy between f and f' , hence f and f' would lie in the same class. So the question may be recast: Given two paths in \tilde{X} from \tilde{x}_0 to \tilde{w} , does there exist a homotopy between them, fixing the endpoints? Spaces that have this property for any pair of points are said to be *simply connected*. In our previous examples the answer to this question is affirmative for

$$\begin{aligned} \exp: \mathbb{R} &\rightarrow S^1, \\ \pi: S^n &\rightarrow \mathbb{R}P(n), \text{ if } n > 1, \text{ and} \\ q: \mathbb{R}^2 &\rightarrow T^2. \end{aligned}$$

However, the restriction of q to the lattice L does not have this property. In L there are paths from $\tilde{x}_0 = (0, 0)$ to $(1, 1)$ that are not homotopic. In other words, there are distinct based homotopy classes of loops in $S_h \vee S_v$ that lift to produce the same terminal point in $q^{-1}(x_0)$.

For a simpler example of this phenomenon, consider the covering space given by the mapping

$$\omega_q: S^1 \rightarrow S^1$$

where $\omega_q(z) = z^q$, for some positive integer q . Taking $q = 3$, consider the two loops α and β in the base, where α traverses S^1 once in a counterclockwise direction and β traverses S^1 four times in the same direction. Then α and β lifted to the same initial point in the total space will produce the same endpoints, but the original loops α and β are not homotopic in the base.

This correspondence also helps in understanding a new algebraic struc-

ture. In the covering space $\exp: \mathbb{R} \rightarrow S^1$, a loop f traversing S^1 once in a counterclockwise direction lifts to produce the integer 1 as its terminal point, if we choose \tilde{x}_0 to be $0 \in \mathbb{R}$. Composing the loop f with itself k times in S^1 forms a loop that produces the integer $k \in \mathbb{R}$. Similarly, reversing the direction along f gives a loop f' that produces $-1 \in \mathbb{R}$, and the composition of f and f' is a loop that produces $0 = \tilde{x}_0$ as its terminal point.

For the covering space $q: \mathbb{R}^2 \rightarrow T^2$, we previously described a loop f in T^2 that lifts to a path in \mathbb{R}^2 from $\tilde{x}_0 = (0, 0)$ to $(1, 2)$. Now let g be a loop at x_0 wrapping once around T^2 in the “horizontal” direction, but with the negative orientation, and let h be a loop at x_0 wrapping twice around T^2 in the “negative vertical” direction. The loop in T^2 produced by traversing f , then g , then h lifts to a path in \mathbb{R}^2 from $(0, 0)$ to $(1, 2)$ to $(0, 2)$ to $(0, 0)$. Since this loop in \mathbb{R}^2 is homotopic to the constant loop at $(0, 0)$, the composed loop in T^2 must be homotopic to the constant loop at x_0 . Note that this conclusion remains valid if the order of the composition of f , g , and h is changed.

A final example shows that this commutative relationship is not always the case. The restriction of q to the lattice L may be described in the same intuitive terms. Let f be a loop in $S_h \vee S_v$ that wraps once around S_h in the positive direction and g be a loop that traverses S_v once in the positive direction (Figure 4.5).

The loop in $S_h \vee S_v$ formed by traversing f first and then g lifts in L to a path from $(0, 0)$ to $(1, 0)$ to $(1, 1)$, while the path formed by traversing g first and then f lifts to a path from $(0, 0)$ to $(0, 1)$ to $(1, 1)$. These two paths in L are *not* homotopic; consequently, the two composed loops in $S_h \vee S_v$ are not homotopic.

To summarize these observations and examples, the based homotopy classes of loops at x_0 in the base space X may be represented by the effect each class has on $p^{-1}(x_0)$. Composition of loops in X provides a product whose effects may be observed, to some degree, on $p^{-1}(x_0)$ in \tilde{X} . From the last example it is clear that the product operation on homotopy classes of loops need not be commutative.

We now make this structure more formal. Let X be a space and $x_0 \in X$. The *fundamental group* or *Poincaré group* $\pi_1(X, x_0)$ is the set of based

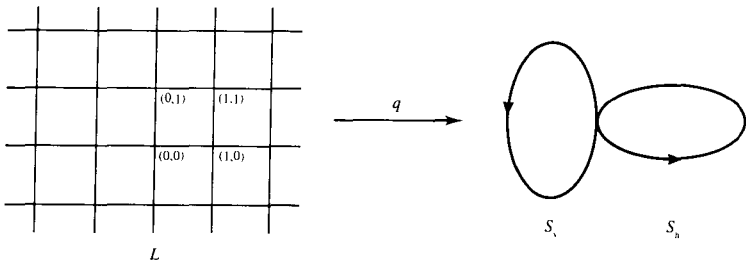

Figure 4.5

homotopy classes of loops at x_0 in X , with product structure given by the composition of loops. That is, if $\alpha: [0, 1] \rightarrow X$ and $\beta: [0, 1] \rightarrow X$ are loops at x_0 , then $\langle \alpha \rangle$ and $\langle \beta \rangle$, the respective homotopy classes, are elements of $\pi_1(X, x_0)$. Their product $\langle \alpha \rangle \cdot \langle \beta \rangle$ is the class in $\pi_1(X, x_0)$ represented by $\alpha \cdot \beta: [0, 1] \rightarrow X$ where

$$\alpha \cdot \beta(t) = \begin{cases} \alpha(2t) & \text{for } 0 \leq t \leq 1/2 \\ \beta(2t - 1) & \text{for } 1/2 \leq t \leq 1. \end{cases}$$

Note that $\alpha \cdot \beta$ is indeed a loop at x_0 .

To see that $\langle \alpha \rangle \cdot \langle \beta \rangle$ is well defined, we must show that the homotopy class of $\alpha \cdot \beta$ does not vary with the choice of representatives in the classes $\langle \alpha \rangle$ and $\langle \beta \rangle$. So suppose $\alpha' \sim \alpha$ and $\beta' \sim \beta$ are other representatives of $\langle \alpha \rangle$ and $\langle \beta \rangle$, respectively. Then there exists a based homotopy

$$F: [0, 1] \times [0, 1] \rightarrow X$$

such that $F(t, 0) = \alpha(t)$ and $F(t, 1) = \alpha'(t)$. Likewise, there exists a based homotopy

$$G: [0, 1] \times [0, 1] \rightarrow X$$

with $G(t, 0) = \beta(t)$ and $G(t, 1) = \beta'(t)$. Then define

$$H: [0, 1] \times [0, 1] \rightarrow X$$

$$\text{by } H(t, s) = \begin{cases} F(2t, s) & \text{if } 0 \leq t \leq 1/2 \text{ and} \\ G(2t - 1, s) & \text{if } 1/2 \leq t \leq 1. \end{cases}$$

The two definitions agree along the segment $t = 1/2$, so H is continuous. $H(t, 0) = \alpha \cdot \beta(t)$ and $H(t, 1) = \alpha' \cdot \beta'(t)$. Clearly, $H(0, s) = x_0 = H(1, s)$ for all s . So $\alpha \cdot \beta$ is homotopic to $\alpha' \cdot \beta'$, and the product $\langle \alpha \rangle \cdot \langle \beta \rangle = \langle \alpha \cdot \beta \rangle$ is well defined.

To see that this product is associative, let α , β , and γ be loops based at x_0 in X . We must show

$$(\langle \alpha \rangle \cdot \langle \beta \rangle) \cdot \langle \gamma \rangle = \langle \alpha \rangle \cdot (\langle \beta \rangle \cdot \langle \gamma \rangle).$$

Restating this in terms of the representing loops, we must show that $(\alpha \cdot \beta) \cdot \gamma$ is homotopic to $\alpha \cdot (\beta \cdot \gamma)$ as loops based at x_0 . Here

$$(\alpha \cdot \beta) \cdot \gamma(t) = \begin{cases} \alpha(4t) & \text{if } 0 \leq t \leq 1/4 \\ \beta(4t - 1) & \text{if } 1/4 \leq t \leq 1/2 \\ \gamma(2t - 1) & \text{if } 1/2 \leq t \leq 1 \end{cases}$$

and

$$\alpha \cdot (\beta \cdot \gamma)(t) = \begin{cases} \alpha(2t) & \text{if } 0 \leq t \leq 1/2 \\ \beta(4t - 2) & \text{if } 1/2 \leq t \leq 3/4 \\ \gamma(4t - 3) & \text{if } 3/4 \leq t \leq 1. \end{cases}$$

Formulating a based homotopy between these two loops becomes easier if viewed geometrically (Figure 4.6).

$$H(s, t) = \begin{cases} \alpha((4/(s + 1))t) & \text{if } s \geq 4t - 1 \\ \beta(4t - s - 1) & \text{if } 4t - 1 \geq s \geq 4t - 2 \\ \gamma((4/(2 - s))(t - (s + 2)/4)) & \text{if } 4t - 2 \geq s. \end{cases}$$

Along the segments where the definitions change, the function H takes each point into x_0 . Consequently, H is continuous and $(\alpha \cdot \beta) \cdot \gamma$ is homotopic to $\alpha \cdot (\beta \cdot \gamma)$.

The identity element of the group $\pi_1(X, x_0)$ is the class of loops homotopic to the constant loop e at x_0 , that is, $e(t) = x_0$ for $0 \leq t \leq 1$. For any element $\langle \alpha \rangle$ in $\pi_1(X, x_0)$ there is an inverse $\langle \alpha \rangle^{-1}$, the class represented by $\bar{\alpha}$, where

$$\bar{\alpha}(t) = \alpha(1 - t).$$

Note that $\bar{\alpha}$ is just the loop α traversed in the opposite direction. To see that $\langle \bar{\alpha} \rangle = \langle \alpha \rangle^{-1}$, we must establish based homotopies between $\alpha \cdot \bar{\alpha}$ and e , and between $\bar{\alpha} \cdot \alpha$ and e (Figure 4.7).

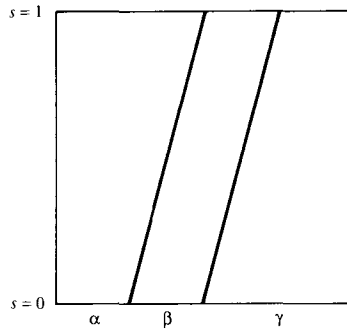

Figure 4.6

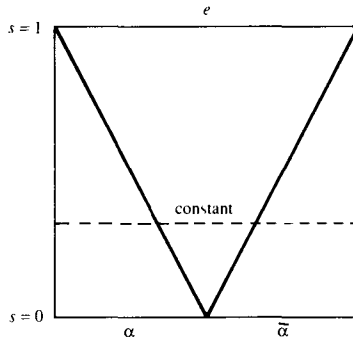

Figure 4.7

On $[0, 1] \times [0, 1]$ define

$$G(s, t) = \begin{cases} \alpha(2t) & \text{if } s \leq 1 - 2t \\ \alpha((1 - s)/2) & \text{if } s \geq 1 - 2t \quad \text{and} \quad s \geq 2t - 1 \\ \bar{\alpha}(2t - 1) & \text{if } s \leq 2t - 1. \end{cases}$$

Note that if a value of s is selected and the loop at level s produced by G is traced, it will proceed along α to the point $\alpha((1 - s)/2)$, remain at that point until $t = (s + 1)/2$, and then retrace that portion of α back to x_0 . When $s = 0$, this yields $\alpha \cdot \bar{\alpha}$; when $s = 1$, this yields e . The verification that $\bar{\alpha} \cdot \alpha$ is homotopic to e is similar.

If (Y, y_0) is another space with designated basepoint, and $f: X \rightarrow Y$ is a continuous function having $f(x_0) = y_0$, then we define

$$f_*: \pi_1(X, x_0) \rightarrow \pi_1(Y, y_0)$$

by $f_*(\langle \alpha \rangle) = \langle f\alpha \rangle$, i.e., the homotopy class represented by the loop at y_0 in Y given by composing f with the loop α . If α' is another representative of $\langle \alpha \rangle$, then a homotopy in X from α to α' may be composed with f to produce a homotopy in Y from $f\alpha$ to $f\alpha'$. Thus $f_*(\langle \alpha \rangle)$ is a well defined element of $\pi_1(Y, y_0)$.

4.5 Proposition. *If $f: (X, x_0) \rightarrow (Y, y_0)$, is a map of pairs, then*

$$f_*: \pi_1(X, x_0) \rightarrow \pi_1(Y, y_0)$$

is a homomorphism of groups.

Proof. The verifications above show that $\pi_1(X, x_0)$ and $\pi_1(Y, y_0)$ are in fact groups. For elements $\langle \alpha \rangle$ and $\langle \beta \rangle$ in $\pi_1(X, x_0)$ represented by paths α and β , it is clear from the definitions that $f_*(\langle \alpha \rangle \cdot \langle \beta \rangle) = f_*(\langle \alpha \rangle) \cdot f_*(\langle \beta \rangle)$. \square

EXAMPLE. Let $\langle \alpha \rangle$ be a class in $\pi_1(S^1, x_0)$, where x_0 is chosen to be the point $(1, 0)$ in S^1 . Using the covering space $\exp: \mathbb{R} \rightarrow S^1$, we lift α to a path in \mathbb{R} with initial point 0. The terminal point of this lift is an integer which we denote $d(\alpha)$. Since any loop homotopic to α must lift to a path with the same terminal point, $d(\alpha)$ depends only on the class of α in $\pi_1(S^1, x_0)$. Consequently, d defines a function from $\pi_1(S^1, x_0)$ to \mathbb{Z} . Note that if the initial point of the lift of α is taken to be the integer k , then the terminal point of the lift will be $k + d(\alpha)$. Consequently, if α and β are loops at x_0 , then $d(\alpha \cdot \beta) = d(\alpha) + d(\beta)$. In other words, we have produced a homomorphism

$$d: \pi_1(S^1, x_0) \rightarrow \mathbb{Z},$$

called the *degree* of the loop.

For any integer m in \mathbb{Z} there is a path $\tilde{\gamma}$ from 0 to m in \mathbb{R} . Projecting this path down to the base, $\gamma = \exp \tilde{\gamma}$ is a loop at x_0 for which $d(\gamma) = m$; hence d is an epimorphism. On the other hand, let α and β be loops in S^1 with

$d(\alpha) = k = d(\beta)$. So the lifts $\tilde{\alpha}$ and $\tilde{\beta}$ are paths in \mathbb{R} with initial point 0 and terminal point k . Define a function

$$H: [0, 1] \times [0, 1] \rightarrow \mathbb{R}$$

by $H(t, s) = (1 - s)\tilde{\alpha}(t) + s\tilde{\beta}(t)$, $0 \leq s \leq 1$. Since \mathbb{R} is convex, this is well defined and continuous. This homotopy from $\tilde{\alpha}$ ($s = 0$) to $\tilde{\beta}$ ($s = 1$) fixes the endpoints at 0 and k throughout the deformation. Then $\exp H$ is a based homotopy from α to β . Therefore $\langle \alpha \rangle = \langle \beta \rangle$, and d is a monomorphism. This completes the proof of the following proposition.

4.6 Proposition. *The degree of a loop defines an isomorphism*

$$d: \pi_1(S^1, x_0) \rightarrow \mathbb{Z}. \quad \square$$

For the next two calculations, we need an important property of maps between finite CW complexes: If X is a k -dimensional finite CW complex, A is a subcomplex, and $f: (X, A) \rightarrow (Y, B)$ is a map of finite CW pairs, then f is relatively homotopic to a map taking X into the k -skeleton of Y . This is a consequence of the Cellular Approximation Theorem (Theorem 2.25).

Now suppose $\langle \alpha \rangle$ is an element of $\pi_1(S^n, x_0)$, $n \geq 2$. If w is a point in the interior of an n -cell of S^n , the preceding property may be applied to produce a representative α' of $\langle \alpha \rangle$ such that w does not lie on the loop α' . Removing w from S^n and projecting stereographically from that point identifies $\{S^n - w\}$ with \mathbb{R}^n . Since \mathbb{R}^n is convex, the loop in \mathbb{R}^n resulting from α' may be deformed into the constant loop. Translating the homotopy back to $\{S^n - w\}$ establishes that α' is homotopically trivial, and $\langle \alpha \rangle = \langle e \rangle$. So the fundamental group of S^n is trivial for $n \geq 2$.

Note that this same argument may be used to show that if $\tilde{\alpha}$ and $\tilde{\beta}$ are paths from y_0 to z_0 in S^n , $n \geq 2$, then $\tilde{\alpha}$ is homotopic to $\tilde{\beta}$ via a deformation keeping the ends fixed at y_0 and z_0 . This observation may be applied to calculate the fundamental group of real projective space.

Suppose $\langle \beta \rangle \in \pi_1(\mathbb{R}P(n), x_0)$, represented by the loop β . Using the covering space

$$\pi: (S^n, y_0) \rightarrow (\mathbb{R}P(n), x_0)$$

we lift β to a path $\tilde{\beta}$ in S^n with initial point y_0 . The terminal point of $\tilde{\beta}$ will be either y_0 or $-y_0$, since $\pi^{-1}(x_0) = \{y_0, -y_0\}$. Define a function

$$\sigma: \pi_1(\mathbb{R}P(n), x_0) \rightarrow Z_2 = \{1, -1\} \text{ by}$$

$$\sigma(\langle \beta \rangle) = \begin{cases} 1 & \text{if the terminal point of } \tilde{\beta} \text{ is } y_0 \\ -1 & \text{if the terminal point of } \tilde{\beta} \text{ is } -y_0. \end{cases}$$

For clarity we are writing the group Z_2 multiplicatively. As before, the function σ is a homomorphism, and the existence of a path in S^n from y_0 to $-y_0$ shows σ is an epimorphism.

Given two loops β and γ in $\mathbb{R}P(n)$ that lift to paths $\tilde{\beta}$ and $\tilde{\gamma}$ with the same

terminal point, the observation above establishes a homotopy from $\tilde{\beta}$ to $\tilde{\gamma}$ in S^n , and subsequently from β to γ in $\mathbb{R}P(n)$. Therefore σ is also a monomorphism. We now summarize these observations.

4.7 Proposition. For $n \geq 2$,

$$\pi_1(S^n, y_0) = 1,$$

and

$$\pi_1(\mathbb{R}P(n), x_0) \approx Z_2. \quad \square$$

EXERCISE 5. Use the covering space $q: \mathbb{R}^2 \rightarrow T^2$ to prove that

$$\pi_1(T^2, x_0) \approx Z \times Z.$$

Some of the results expressed previously in terms of covering spaces may now be reformulated in the framework of fundamental groups and induced homomorphisms.

4.8 Proposition. If $p: \tilde{X} \rightarrow X$ is a covering space, then the induced homomorphism

$$p_*: \pi_1(\tilde{X}, \tilde{x}_0) \rightarrow \pi_1(X, x_0)$$

is a monomorphism.

Proof. Suppose $\tilde{\gamma}$ is a loop at \tilde{x}_0 in \tilde{X} with $p_*(\langle \tilde{\gamma} \rangle)$ trivial in $\pi_1(X, x_0)$. That is, there exists a homotopy in X from $p\tilde{\gamma}$ to the constant loop. By Proposition 1.3, this homotopy lifts to a homotopy in \tilde{X} between $\tilde{\gamma}$ and the constant loop at \tilde{x}_0 . Thus $\langle \tilde{\gamma} \rangle$ is trivial in $\pi_1(\tilde{X}, \tilde{x}_0)$, and p_* is a monomorphism. \square

4.9 Theorem. If $p: \tilde{X} \rightarrow X$ is a covering space, Y is pathwise connected, and $f: Y \rightarrow X$ is a continuous function, then a necessary and sufficient condition for the existence of a lift $\tilde{f}: Y \rightarrow \tilde{X}$ is that $f_*(\pi_1(Y, y_0)) \subseteq p_*(\pi_1(\tilde{X}, \tilde{x}_0))$.

Proof. The necessity of the condition is evident, since the existence of a lift \tilde{f} means the following diagram is commutative.

$$\begin{array}{ccc} & & \pi_1(\tilde{X}, \tilde{x}_0) \\ & \nearrow \tilde{f}_* & \downarrow p_* \\ \pi_1(Y, y_0) & \xrightarrow{f_*} & \pi_1(X, x_0). \end{array}$$

Since $f_* = p_*\tilde{f}_*$, the image of f_* is contained in the image of p_* .

Now suppose that $f_*(\pi_1(Y, y_0)) \subseteq p_*(\pi_1(\tilde{X}, \tilde{x}_0))$, and let y be a point of Y . Pick a path ω in Y with $\omega(0) = y_0$ and $\omega(1) = y$. Then $f\omega$ is a path in X from x_0 to $f(y)$. Lift this path in X to a path $\tilde{\omega}$ in \tilde{X} with initial point \tilde{x}_0 . Define

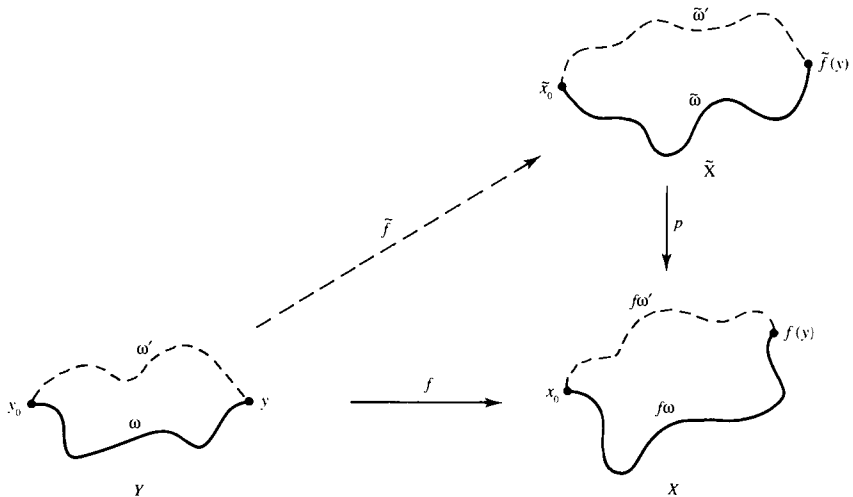

Figure 4.8

$\tilde{f}(y) = \tilde{\omega}(1)$. This is our candidate for a lifting of the map f . As it is defined, it is clear that $f = p\tilde{f}$ (Figure 4.8).

We must show that the function \tilde{f} is well defined and continuous. First we show that the definition of $\tilde{f}(y)$ is not dependent on the choice of the path ω . Suppose that ω' is another path from y_0 to y . Then $(\omega')^{-1}\omega$ is a loop at y_0 . The image under f_* of this loop is a loop β at x_0 . Thus there is a loop $\tilde{\beta}$ at \tilde{x}_0 with $p_*(\langle \tilde{\beta} \rangle) = \langle \beta \rangle$, that is, $p\tilde{\beta}$ and β are homotopic.

Take a homotopy between these loops in X , and lift the homotopy to \tilde{X} with initial point \tilde{x}_0 . Since the loop $\tilde{\beta}$ is closed, the lift of β must also be closed. Another way of expressing this is that, the lifts of $f(\omega)$ and $f(\omega')$, which begin at \tilde{x}_0 , must both end at the same point in \tilde{X} . This means that $\tilde{\omega}(1) = \tilde{\omega}'(1)$, so the image of y under \tilde{f} is well defined.

To see that \tilde{f} is continuous, let y and ω be as above, and take an open set U about $\tilde{f}(y)$ in \tilde{X} . Since p is a covering map, we may assume that p maps U homeomorphically onto a connected open set $p(U)$. Then $f^{-1}(p(U))$ is an open set about y . Y is locally pathwise connected, so there is a pathwise connected open set V about y contained in $f^{-1}(p(U))$. If z is any other point of V , there is a path in V from y to z . Composing this path with ω produces a path from y_0 to z . Since the definition of $\tilde{f}(z)$ does not depend on the choice of path from y_0 to z , we may use this composition; hence it is clear that $\tilde{f}(z) \in U$. This proves that \tilde{f} is continuous, so we have established the existence of a lifting. \square

This theorem is remarkable in that it describes an *algebraic* condition that is *sufficient* for the existence of a lifting of f . Practically all of the applications we have encountered have involved *necessary* algebraic conditions for the

existence of certain topological features. This theorem is appealing in that it not only describes a sufficient condition for the existence of a lift, but also provides a concise description of the lift itself.

EXAMPLE. For any positive integer q , we earlier defined ω_q to be the standard map of degree q on S^1

$$\omega_q: S^1 \rightarrow S^1$$

given in complex coordinates by taking $z \in S^1$ into z^q . For this covering space the image of $\omega_{q*}: \pi_1(S^1, x_0) \rightarrow \pi_1(S^1, x_0)$ is the subgroup $q\mathbb{Z}$. Consequently, if $q > 1$, no map

$$\omega_r: S^1 \rightarrow S^1$$

lifts through ω_q unless q divides r . In particular, taking $r = 1$, ω_r is the identity and there is no “cross section” of the map ω_q for $q > 1$, i.e., there is no map $s: S^1 \rightarrow S^1$ such that $\omega_q s =$ the identity.

An obvious question that must be considered is how the choice of the basepoint x_0 in X affects the fundamental group. Clearly, $\pi_1(X, x_0)$ can carry information only on the path component containing x_0 . So assume that X is pathwise connected, and let x_1 be another point of X . Select a path α in X with $\alpha(0) = x_0$ and $\alpha(1) = x_1$ (Figure 4.9).

Given a loop β based at x_1 , we produce a loop at x_0 by taking the composition $\alpha^{-1}\beta\alpha$. Note that if β is modified to β' via a homotopy based at x_1 , then composing this homotopy with α and α^{-1} as above shows that the loops $\alpha^{-1}\beta'\alpha$ and $\alpha^{-1}\beta\alpha$ are homotopic, based at x_0 . The correspondence $\beta \rightarrow \alpha^{-1}\beta\alpha$ therefore defines a function

$$h_\alpha: \pi_1(X, x_1) \rightarrow \pi_1(X, x_0).$$

4.10 Proposition.

- (a) h_α is an isomorphism of groups.
- (b) If α' is another path from x_0 to x_1 which is homotopic to α via a homotopy fixing the endpoints, then $h_{\alpha'} = h_\alpha$.
- (c) If α^{-1} is defined by $\alpha^{-1}(t) = \alpha(1 - t)$, then $(h_\alpha)^{-1} = h_{\alpha^{-1}}$.

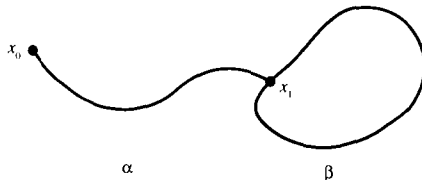

Figure 4.9

Proof. We prove only that h_x is one-to-one, leaving the remaining parts as an exercise. Suppose β is a loop at x_1 with $h_x(\beta)$ homotopically trivial at x_0 . So there exists a homotopy based at x_0 between $\alpha^{-1}\beta\alpha$ and e_0 , the constant path at x_0 . To see that β is homotopic to e_1 , we modify β through several steps.

First note that as loops at x_1 , β is homotopic to $(\alpha\alpha^{-1})\beta(\alpha\alpha^{-1})$. This composition may be reassociated as $\alpha(\alpha^{-1}\beta\alpha)\alpha^{-1}$ within the same homotopy class at x_1 . Now apply the homotopy from $(\alpha^{-1}\beta\alpha)$ to e_0 to show the composition is homotopic to $\alpha(e_0)\alpha^{-1}$. Finally, note that $\alpha(e_0)\alpha^{-1}$ as a loop at x_1 is homotopic to e_1 .

In summary, if $h_x(\langle\beta\rangle) = 1$, then $\langle\beta\rangle = 1$ in $\pi_1(X, x_1)$. \square

EXERCISE 6. Prove the remaining parts of Proposition 4.10 (a), (b), and (c).

We look briefly at an example to see that if a path γ from x_0 to x_1 is not homotopic to α , then h_γ need not be the same isomorphism as h_x . Consider $X = S_h \vee S_v$ with its covering space $q: L \rightarrow S_h \vee S_v$. Let x_0 be the point of intersection of the two circles, and let x_1 be antipodal to x_0 on the horizontal circle (Figure 4.10).

Let α be the horizontal path from x_0 to x_1 which lifts in L to the segment from $(0, 0)$ to $(1/2, 0)$. Let γ be the path from x_0 that traverses the vertical circle once and then follows α from x_0 to x_1 , lifting in L to the segment from $(0, 0)$ to $(0, 1)$ to $(1/2, 1)$.

Now take β to be the loop at x_1 traversing S_h once in the positive direction. Note that $h_x(\beta) = \alpha^{-1}\beta\alpha$, as a loop at x_0 , lifts in L to a path from $(0, 0)$ to $(1/2, 0)$ to $(3/2, 0)$ to $(1, 0)$. On the other hand, $h_\gamma(\beta) = \gamma^{-1}\beta\gamma$, as a loop at x_0 , lifts in L to the path from $(0, 0)$ to $(0, 1)$ to $(1/2, 1)$ to $(3/2, 1)$ to $(1, 1)$ to $(1, 0)$.

Although these paths in L have the same endpoints, they are not homotopic. If $h_x(\beta)$ and $h_\gamma(\beta)$ were homotopic as loops at x_0 , the homotopy between them could be lifted to L . So for this example the isomorphisms h_x and h_γ are not the same.

Note that if we take $x_1 = x_0$, then h_x becomes an inner automorphism of $\pi_1(X, x_0)$, that is

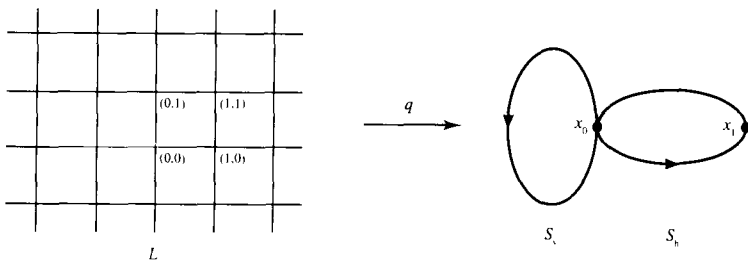

Figure 4.10

$$h_\alpha(\langle \beta \rangle) = \langle \alpha \rangle^{-1} \langle \beta \rangle \langle \alpha \rangle.$$

Of course, if $\pi_1(X, x_0)$ is abelian, then any such isomorphism is the identity.

Now suppose $p: \tilde{X} \rightarrow X$ is a covering space in which \tilde{X} is pathwise connected. The lifting theorem (4.9) was concerned with the image of the homomorphism

$$p_*: \pi_1(\tilde{X}, \tilde{x}_0) \rightarrow \pi_1(X, x_0).$$

Is this subject to change with the choice of \tilde{x}_0 in $p^{-1}(x_0)$? In general the answer is yes, but the variation can be precisely characterized.

4.11 Proposition. *If $p: \tilde{X} \rightarrow X$ is a covering space with \tilde{X} pathwise connected, then as y ranges over the points of $p^{-1}(x_0)$, $p_*(\pi_1(\tilde{X}, y))$ ranges over all conjugates of $p_*(\pi_1(\tilde{X}, \tilde{x}_0))$ in $\pi_1(X, x_0)$.*

Proof. Let $y \in p^{-1}(x_0)$ and select a path $\tilde{\alpha}$ in \tilde{X} from \tilde{x}_0 to y . Then $\alpha = p\tilde{\alpha}$ is a loop at x_0 , and

$$\begin{aligned} p_*(\pi_1(\tilde{X}, y)) &= p_*(h_{\tilde{\alpha}}(\pi_1(\tilde{X}, \tilde{x}_0))) \\ &= h_\alpha(p_*(\pi_1(\tilde{X}, \tilde{x}_0))) \end{aligned}$$

shows that $p_*(\pi_1(\tilde{X}, y))$ is a conjugate of $p_*(\pi_1(\tilde{X}, \tilde{x}_0))$.

On the other hand, let $\langle \phi \rangle \in \pi_1(X, x_0)$ and consider the conjugate $\langle \phi \rangle^{-1} p_*(\pi_1(\tilde{X}, \tilde{x}_0)) \langle \phi \rangle$. Lift the loop $\eta = \phi^{-1}$ to a path $\tilde{\eta}$ in \tilde{X} with initial point \tilde{x}_0 . Taking $y = \tilde{\eta}(1)$, we see that

$$\begin{aligned} p_*(\pi_1(\tilde{X}, y)) &= p_*(h_{\tilde{\eta}}(\pi_1(\tilde{X}, \tilde{x}_0))) \\ &= h_\eta(p_*(\pi_1(\tilde{X}, \tilde{x}_0))) \\ &= \langle \eta \rangle p_*(\pi_1(\tilde{X}, \tilde{x}_0)) \langle \eta \rangle^{-1} \\ &= \langle \phi \rangle^{-1} p_*(\pi_1(\tilde{X}, \tilde{x}_0)) \langle \phi \rangle. \end{aligned}$$

So each conjugate of $p_*(\pi_1(\tilde{X}, \tilde{x}_0))$ in $\pi_1(X, x_0)$ is an image for some choice of y . □

This result allows us to state the lifting theorem (Proposition 4.9) in a more general form:

4.12 Corollary. *If $p: \tilde{X} \rightarrow X$ is a covering space, Y is pathwise connected, and $f: Y \rightarrow X$ is a continuous function, then a necessary and sufficient condition for the existence of a lift $\tilde{f}: Y \rightarrow \tilde{X}$ is that $f_*(\pi_1(Y, y_0))$ be contained in some conjugate of $p_*(\pi_1(\tilde{X}, \tilde{x}_0))$.* □

Note that two choices for y in $p^{-1}(x_0)$ may yield the same conjugate in $\pi_1(X, x_0)$. In fact, all y will yield the same conjugate in the case that

$p_*(\pi_1(\tilde{X}, \tilde{x}_0))$ is normal in $\pi_1(X, x_0)$. In particular, this is the case if $\pi_1(X, x_0)$ is abelian.

From our examples we have seen a family of connected covering spaces with base space S^1 :

- (a) For each positive integer m , the m -fold covering

$$\omega_m: S^1 \rightarrow S^1; \text{ and}$$

- (b) The exponential map

$$\exp: \mathbb{R} \rightarrow S^1.$$

It is natural to ask how these are related, or, more specifically, when does there exist a mapping of covering spaces that preserves the covering relationship? The answer will rely on the lifting theorem, but first we consider the more general setting.

Suppose $q: \tilde{W} \rightarrow X$ and $p: \tilde{X} \rightarrow X$ are covering spaces over the same base space X . A *homomorphism of covering spaces* (or a *map of covering spaces*) is a continuous function $f: \tilde{W} \rightarrow \tilde{X}$, such that $pf(\tilde{w}) = q(\tilde{w})$ for every \tilde{w} in \tilde{W} . In other words, the following triangle is commutative

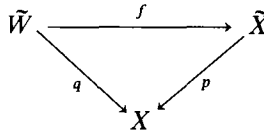

The homomorphism f is an *isomorphism* if there exists a homomorphism $h: \tilde{X} \rightarrow \tilde{W}$ with fh and hf the respective identity maps.

It will supplement our understanding of covering spaces if we can establish how such mappings arise and how they are related to the subgroups of the fundamental group of the base, X . For this analysis we will consider only covering spaces in which X is pathwise connected.

4.13 Lemma. *If $q: \tilde{W} \rightarrow X$ and $p: \tilde{X} \rightarrow X$ are covering spaces over a pathwise connected base X , and $f: \tilde{W} \rightarrow \tilde{X}$ is a mapping of covering spaces in which f maps \tilde{W} onto \tilde{X} , then f itself is a covering space.*

Proof. Given \tilde{x} in \tilde{X} , we must produce a fundamental open set for f about \tilde{x} . Since both q and p are covering maps, there exist about $p(\tilde{x})$ fundamental open sets V_1 for q and V_2 for p . Let U be the component of $V_1 \cap V_2$ containing $p(\tilde{x})$, and consider $p^{-1}(U)$. Each component of $p^{-1}(U)$ is mapped homeomorphically onto U via p . Let \tilde{U} be the component of $p^{-1}(U)$ containing \tilde{x} .

Now $f^{-1}(p^{-1}(U)) = q^{-1}(U)$, and each component of this set is mapped homeomorphically onto U via q . Since f is onto, at least one of these components must contain a point of $f^{-1}(\tilde{x})$. By composing homeomorphisms we see that each component of $f^{-1}(\tilde{U})$, i.e., those components of $q^{-1}(U)$ that contain a point of $f^{-1}(\tilde{x})$, is mapped homeomorphically onto \tilde{U} . Thus f is a covering map. □

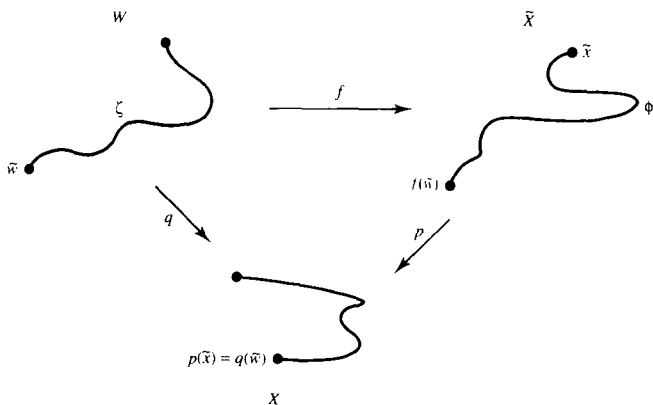

Figure 4.11

4.14 Lemma. *If $q: \tilde{W} \rightarrow X$ and $p: \tilde{X} \rightarrow X$ are covering spaces over a pathwise connected base X in which both \tilde{W} and \tilde{X} are pathwise connected, then any mapping of covering spaces $f: \tilde{W} \rightarrow \tilde{X}$ is itself a covering space.*

Proof. By the previous lemma it suffices to show that f is onto. Given \tilde{x} in \tilde{X} , select a point \tilde{w} in $q^{-1}(p(\tilde{x}))$ (Figure 4.11). Since \tilde{X} is pathwise connected, there is a path ϕ in \tilde{X} from $f(\tilde{w})$ to \tilde{x} . Projecting this path down into X gives a path based at $q(\tilde{w}) = p(\tilde{x})$. There is a unique lift of this path to \tilde{W} with initial point \tilde{w} . Call this path ζ . Now $f\zeta$ and ϕ are paths in \tilde{X} with initial point $f(\tilde{w})$, projecting via p into the same path in X . By the uniqueness of lifts, $f\zeta$ and ϕ must be the same path. Thus $\tilde{x} = \phi(1) = f(\zeta(1))$ is in the image of f , and f is onto.

We conclude that $f: \tilde{W} \rightarrow \tilde{X}$ is a covering space. \square

Note that these two results place significant limitations on the continuous maps from \tilde{W} to \tilde{X} that can be homomorphisms of covering spaces. The following propositions provide further restrictions, as well as specific conditions for the existence of a homomorphism.

4.15 Proposition. *If $q: \tilde{W} \rightarrow X$ and $p: \tilde{X} \rightarrow X$ are covering spaces with \tilde{W} and \tilde{X} pathwise connected, and $f, g: \tilde{W} \rightarrow \tilde{X}$ are homomorphisms of covering spaces for which $g(\tilde{w}) = f(\tilde{w})$ for some point \tilde{w} in \tilde{W} , then $f = g$.*

Proof. Since f and g are both “liftings” of q to \tilde{X} , and since \tilde{W} is pathwise connected, we may apply Proposition 4.2. In other words, if f and g agree at a point, they are identical on \tilde{W} . \square

In the special case that $\tilde{W} = \tilde{X}$, an isomorphism of the covering space is called an *automorphism*. The following observation is an immediate consequence of Proposition 4.15:

4.16 Corollary. *If $f: \tilde{X} \rightarrow \tilde{X}$ is an automorphism of a pathwise connected covering space $p: \tilde{X} \rightarrow X$, and f is not the identity, then f is fixed-point free.* \square

4.17 Proposition. *Let $q: \tilde{W} \rightarrow X$ and $p: \tilde{X} \rightarrow X$ be covering spaces with \tilde{W} pathwise connected. If $q_*(\pi_1(\tilde{W}, \tilde{w}_0))$ is contained in a conjugate of $p_*(\pi_1(\tilde{X}, \tilde{x}_0))$, then there exists a homomorphism $f: \tilde{W} \rightarrow \tilde{X}$.*

Proof. This follows directly from the Lifting Theorem (4.9). Note that we may not be able to require that the homomorphism take \tilde{w}_0 into \tilde{x}_0 . \square

A covering space $p: \tilde{X} \rightarrow X$ is *regular* if, for each closed path α in X , either all lifts of α to \tilde{X} are closed or no lift of α is closed.

EXERCISE 7. (a) Let $p: \tilde{X} \rightarrow X$ be a covering space with \tilde{X} pathwise connected. Then prove that (\tilde{X}, p) is regular if and only if for any points \tilde{x}_1 and \tilde{x}_2 in $p^{-1}(x_0)$ there is an automorphism of (\tilde{X}, p) taking \tilde{x}_1 into \tilde{x}_2 .

(b) Show that the covering space $p: \tilde{X} \rightarrow X$, with \tilde{X} pathwise connected, is regular if and only if $p_*(\pi_1(\tilde{X}, \tilde{x}_0)) = p_*(\pi_1(\tilde{X}, \tilde{x}_1))$ for every \tilde{x}_0 and \tilde{x}_1 in $p^{-1}(x_0)$.

(c) Find an example of a covering space, with \tilde{X} pathwise connected, which is not regular.

4.18 Proposition. *Let $q: \tilde{W} \rightarrow X$ and $p: \tilde{X} \rightarrow X$ be covering spaces with \tilde{W} pathwise connected. There is a homomorphism $f: \tilde{W} \rightarrow \tilde{X}$ with $f(\tilde{w}_0) = \tilde{x}_0$ if and only if $q_*(\pi_1(\tilde{W}, \tilde{w}_0))$ is contained in $p_*(\pi_1(\tilde{X}, \tilde{x}_0))$.* \square

We can summarize these results in the following theorem:

4.19 Proposition. *Two pathwise connected covering spaces $q: \tilde{W} \rightarrow X$ and $p: \tilde{X} \rightarrow X$ are isomorphic if and only if for any two points \tilde{w}_0 and \tilde{x}_0 lying above x_0 , $q_*(\pi_1(\tilde{W}, \tilde{w}_0))$ and $p_*(\pi_1(\tilde{X}, \tilde{x}_0))$ are conjugate in $\pi_1(X, x_0)$.*

Proof. If the image subgroups are conjugate in $\pi_1(X, x_0)$, then using Proposition 4.11, we can change the basepoint in \tilde{W} to \tilde{w}_1 so that the images of q_* and p_* are equal. Applying Proposition 4.18, there exist homomorphisms $f: \tilde{W} \rightarrow \tilde{X}$ and $h: \tilde{X} \rightarrow \tilde{W}$ with $f(\tilde{w}_1) = \tilde{x}_0$ and $h(\tilde{x}_0) = \tilde{w}_1$. Now by Corollary 4.16 each composition must be the respective identity, since $hf(\tilde{w}_1) = \tilde{w}_1$ and $f h(\tilde{x}_0) = \tilde{x}_0$.

Conversely, an isomorphism $f: \tilde{W} \rightarrow \tilde{X}$ implies the images of p_* and q_* are equal for one choice of basepoints. By Proposition 4.11, varying the basepoints within $q^{-1}(x_0)$ and $p^{-1}(x_0)$ will produce conjugate subgroups as images. \square

At this point we have established that isomorphism classes of pathwise connected covering spaces of (X, x_0) give rise to conjugacy classes of sub-

groups of $\pi_1(X, x_0)$. Furthermore, homomorphisms of pathwise connected covering spaces (which are themselves covering spaces) correspond to “inclusion” of conjugacy classes, i.e., one conjugacy class is “included” in another if each subgroup in the first is contained in some subgroup in the second.

There is one remaining piece of the puzzle that is more difficult to resolve: Given a conjugacy class of subgroups of $\pi_1(X, x_0)$, does there exist a covering space $p: \tilde{X} \rightarrow X$ with $p_*(\pi_1(\tilde{X}, \tilde{x}_0))$ in this class? We will outline the answer to this question; for more details see Massey [1967].

The simplest nontrivial case is associated with the conjugacy class of the subgroup $\{1\}$. That is, since s_* is a monomorphism, we seek a pathwise connected covering space $s: \tilde{E} \rightarrow X$ with $\pi_1(\tilde{E}, \tilde{e}_0) = \{1\}$. Such a covering space is called a *universal covering space* because it exhibits the following *universal mapping property*: For any covering space $p: \tilde{X} \rightarrow X$, there exists a homomorphism $f: (\tilde{E}, s) \rightarrow (\tilde{X}, p)$. This holds for (\tilde{E}, s) since $s_*(\pi_1(\tilde{E}, \tilde{e}_0)) = \{1\}$ is a subgroup of every image.

Now suppose $\pi_1(\tilde{E}, \tilde{e}_0) = \{1\}$, and let U be a fundamental open set about x_0 and V a component of $s^{-1}(U)$ mapped homeomorphically onto U by s . The diagram

$$\begin{array}{ccc}
 \pi_1(V, \tilde{e}_0) & \xrightarrow{i_*} & \pi_1(\tilde{E}, \tilde{e}_0) \\
 (s|_V)_* \approx \downarrow & & \downarrow s_* \\
 \pi_1(U, x_0) & \xrightarrow{j_*} & \pi_1(X, x_0)
 \end{array}$$

is commutative, where i and j are inclusion maps. Now $(s|_V)_*$ is an isomorphism, and $\pi_1(\tilde{E}, \tilde{e}_0) = \{1\}$, so any nontrivial element of $\pi_1(U, x_0)$ must be in the kernel of j_* . In other words, any nontrivial loop in U , based at x_0 , must be homotopically trivial in X . A space with this property at each point is said to be *semilocally simply connected*. Put more directly, a space Y is semilocally simply connected if for each y in Y there exists an open set V about y such that any loop in V , based at y , is homotopic in Y to the constant loop at y .

EXERCISE 8. Find an example of a space Y that is *not* semilocally simply connected.

The preceding discussion shows that if X fails to be semilocally simply connected, then X will not have a simply connected covering space. However, there are examples of universal covering spaces, i.e., covering spaces with the universal mapping property, in which the total space is not simply connected. See Spanier [1966] for a specific example.

For our purposes we will assume the space X is semilocally simply connected; this is the case for all manifolds and finite CW complexes. So given a pathwise connected base (X, x_0) , consider the set of all paths in X with initial point x_0 . For any point x_1 in X , the paths from x_0 to x_1 fall into distinct

homotopy classes (with endpoints fixed). The homotopy classes of paths become the points of the space \tilde{E} . Take \tilde{e}_0 to be the class of the constant loop at x_0 . The function $s: \tilde{E} \rightarrow X$ assigns to a homotopy class the endpoint x_1 in X .

Our assumptions regarding the local properties of X allow a topology to be introduced in \tilde{E} so that s is continuous and is, in fact, a covering space. To see why \tilde{E} will be simply connected, take a nontrivial loop at x_0 in X . This represents a homotopy class, hence a point in \tilde{E} lying above x_0 , but *not* equal to \tilde{e}_0 . Thus any nontrivial loop at x_0 lifts to a nonclosed path in \tilde{E} . Since s_* is a monomorphism, there can be *no* nontrivial loops at \tilde{e}_0 in \tilde{E} . Therefore \tilde{E} is simply connected.

Now suppose $s: \tilde{E} \rightarrow X$ has $\pi_1(\tilde{E}, \tilde{e}_0) = \{1\}$ and let G be a subgroup of $\pi_1(X, x_0)$. Each element g in G produces, via lifting the path to \tilde{e}_0 , a point $g\tilde{e}_0$ in $s^{-1}(x_0)$, and consequently an automorphism of \tilde{E} . This action of G on \tilde{E} is particularly nice, due to Corollary 4.16 and the properties of \tilde{E} . The quotient space \tilde{E}/G admits a map

$$r: \tilde{E}/G \rightarrow X$$

that is a covering space, and $r_*(\pi_1(\tilde{E}/G, \{\tilde{e}_0\}))$ is equal to the subgroup G . For example, start with a loop α in G . Lift α to a path in \tilde{E} from \tilde{e}_0 to \tilde{e}_1 . These two points are identified in the quotient \tilde{E}/G , and the resulting loop is mapped via r_* to α .

We summarize these observations in the following theorem. Again, for a complete proof, see Massey [1967].

4.20 Theorem. *For a semilocally simply connected space (X, x_0) the isomorphism classes of pathwise connected covering spaces of (X, x_0) are in one-to-one correspondence with the conjugacy classes of subgroups of $\pi_1(X, x_0)$. \square*

EXAMPLE. We return to the connected covering spaces of S^1 . Writing $\pi_1(S^1, x_0) \approx \mathbb{Z}$ multiplicatively with generator θ , for each positive integer n there is a subgroup $n\mathbb{Z} = \{\theta^{nk} | k \in \mathbb{Z}\}$. Together with $\{1\}$, this is the complete set of subgroups of $\pi_1(S^1, x_0)$, and each is its own conjugacy class. For $m > 0$, $\omega_m: S^1 \rightarrow S^1$, the m -fold covering, has

$$\text{image}(\omega_{m*}) = m\mathbb{Z} \subseteq \pi_1(S^1, x_0).$$

Of course, \exp_* has image $\{1\}$. Consequently, as m ranges over all positive integers, we produce all isomorphism classes of connected covering spaces of S^1 . Furthermore, there is a homomorphism of covering spaces

$$f: (S^1, \omega_m) \rightarrow (S^1, \omega_k)$$

if and only if k divides m .

EXERCISE 9. If $p: \tilde{X} \rightarrow X$ is a covering space with \tilde{X} pathwise connected, define the *multiplicity* of p (or the *number of sheets* of p) to be the cardinality of $\{p^{-1}(x_0)\}$. Prove that the multiplicity of p is the index of $p_*(\pi_1(\tilde{X}, \tilde{x}_0))$ in $\pi_1(X, x_0)$.

There is a clear relationship between the fundamental group and the first singular homology group for a pathwise connected space. As we have seen, both assign a group to a space and a homomorphism of groups to a continuous map of spaces. Furthermore, homotopic maps are seen to induce the same homomorphism. For certain familiar spaces, e.g., spheres, projective spaces, and the torus, the fundamental groups are isomorphic to the homology groups, so one might begin to believe there is little new information contained in the fundamental group. The first major distinction lies in the observation that fundamental groups need not be abelian. Indeed, a space as simple as the join of two circles readily produced a product of loops that do not commute.

A less obvious distinction lies in the absence of a process in the fundamental group that is analogous to the subdivision procedure in singular homology. While a loop in a space bears a striking resemblance to a singular 1-simplex, it cannot be subdivided into smaller loops the way a simplex may be decomposed into smaller simplices. This difference means we can expect no Mayer-Vietoris sequence as an aid to making computations. However, there is an analogous theorem for the fundamental group that will be discussed later in this chapter.

For now let us focus attention on the specific connections between $\pi_1(X, x_0)$ and $H_1(X)$. Given a loop α at x_0 in X , we think of α as a map of pairs $\alpha: (I, \partial I) \rightarrow (X, x_0)$, where $I = [0, 1]$. Then α induces a homomorphism on the first relative homology groups

$$\alpha_*: H_1(I, \partial I) \rightarrow H_1(X, x_0).$$

If σ denotes a chosen generator for $H_1(I, \partial I)$, corresponding to an orientation for the interval I , then the element $\alpha_*(\sigma)$ in $H_1(X, x_0)$ suggests a function from loops at x_0 into $H_1(X, x_0)$. Note that if α' is a loop at x_0 , based homotopic to α , then $\alpha'_* = \alpha'_*$ and $\alpha'_*(\sigma) = \alpha'_*(\sigma)$.

Thus we have a function

$$h: \pi_1(X, x_0) \rightarrow H_1(X, x_0)$$

called the *Hurewicz homomorphism*. To see that h actually carries the product in π_1 into the sum in H_1 , we return to the level of singular cycles and chains. Note that $h(\langle \alpha \rangle)$ may be represented by the singular 1-simplex $\alpha: I \rightarrow X$, a relative 1-cycle in the pair (X, x_0) . Similarly, for $\langle \beta \rangle$ in $\pi_1(X, x_0)$ we think of β as a relative 1-cycle. The product $\langle \alpha \rangle \langle \beta \rangle$ is assigned by h to the homology class represented by the relative 1-cycle dictated by α on the first half of the interval and by β on the second half. To establish that this cycle is homologous to the sum of the cycles representing $h(\langle \alpha \rangle)$ and $h(\langle \beta \rangle)$, consider the relative singular 2-simplex depicted in Figure 4.12.

Along the edge from v_0 to v_1 the value is $\langle \alpha \rangle \langle \beta \rangle$. The segment, λ , from the midpoint of this edge to the vertex v_2 is mapped into x_0 . The edge from v_0 to v_2 is mapped via α , suitably parameterized, as is each ray emanating from v_0 to a point on λ . Similarly, the edge from v_2 to v_1 is mapped via β , as is each ray starting at a point of λ and ending at v_1 . The resulting singular 2-simplex

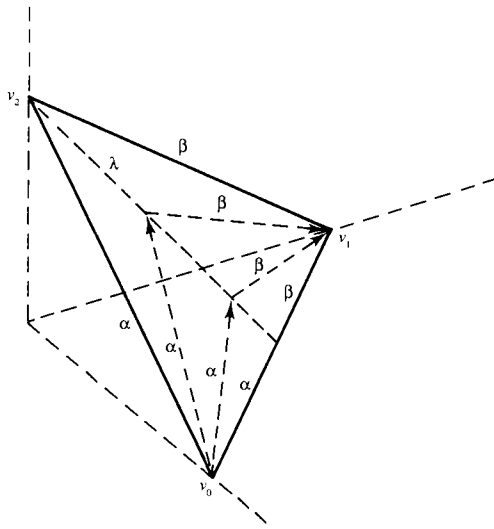

Figure 4.12

has as its boundary a relative 1-cycle representing $h(\langle \alpha \rangle \langle \beta \rangle) - h(\langle \alpha \rangle) - h(\langle \beta \rangle)$. Thus

$$h: \pi_1(X, x_0) \rightarrow H_1(X, x_0)$$

is a homomorphism of groups.

4.21 Proposition. *The Hurewicz homomorphism*

$$h: \pi_1(X, x_0) \rightarrow H_1(X, x_0)$$

is an epimorphism with kernel the commutator subgroup of $\pi_1(X, x_0)$.

Proof. To see that h is an epimorphism, suppose τ is a relative 1-cycle in (X, x_0) . Then τ is a finite sum of singular 1-simplices

$$\tau = \sum m_i \phi_i$$

where $\partial\tau = 0$. Note that, for each i , $\partial\phi_i$ is the difference of two 0-simplices, i.e., the algebraic difference of two points in X . The fact that $\partial\tau = 0$ in the relative chain group means the algebraic sum of all points outside of $\{x_0\}$ is zero.

Consider the set of all 0-simplices arising from the relative 1-chain τ . We think of each of these as a point in X . For each 0-simplex y_i in this finite set, choose a path ω_i from x_0 to y_i . This can be done since X is pathwise connected. If y_i happens to be x_0 , we choose the path to be constant. Call this the collection of “vertex paths” from x_0 to the 1-chain τ (Figure 4.13).

Now suppose ϕ_j is a 1-simplex in τ , with $\partial\phi_j = y_k - y_m$. The composition $\omega_k^{-1}\phi_j\omega_m$ is a loop at x_0 that traverses ϕ_j in the positive direction. Let β in

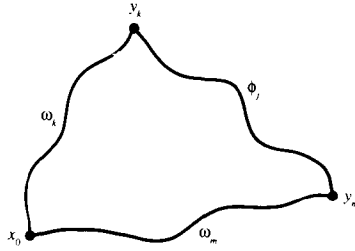

Figure 4.13

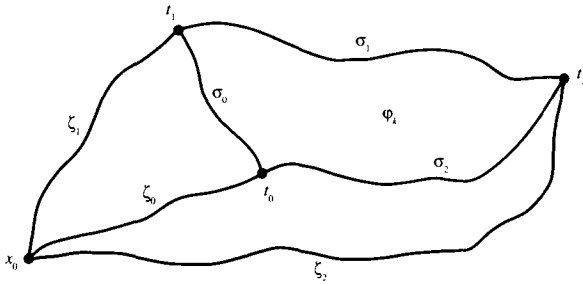

Figure 4.14

$\pi_1(X, x_0)$ be the product of all such loops arising from 1-simplices in τ , taken with multiplicity dictated by the coefficients in the associated sum. Let us intuitively examine $h(\langle\beta\rangle)$. Since $\partial\tau = 0$, each 0-simplex outside x_0 sums algebraically to 0. Consequently, the path ω_i occurs in β the same number of times as ω_i^{-1} . Therefore, when viewed as singular 1-simplices, all the vertex paths in $h(\langle\beta\rangle)$ sum to 0, and the remaining paths produce τ . Hence $h(\langle\beta\rangle) = \tau$, and h is an epimorphism.

To analyze the kernel of h , suppose α is a loop at x_0 with $h(\langle\alpha\rangle) = 0$. In other words, when considered as a relative cycle, α is a boundary. So there exists a relative 2-chain $\theta = \sum m_i\varphi_i$ in X with $\partial\theta = \alpha$. As before, we select a finite family of “vertex paths” from x_0 to the 0-simplices of θ . Denote the 0-simplices of θ by $\{t_n\}$ and the corresponding vertex paths by $\{\zeta_n\}$ (Figure 4.14). Suppose $\partial\varphi_k = \langle t_0, t_1 \rangle + \langle t_1, t_2 \rangle + \langle t_2, t_0 \rangle = \sigma_0 + \sigma_1 + \sigma_2$. Then consider the composition

$$\lambda_k = (\zeta_0^{-1}\sigma_2\zeta_2)(\zeta_2^{-1}\sigma_1\zeta_1)(\zeta_1^{-1}\sigma_0\zeta_0).$$

Note that since this loop arises as the boundary of a 2-simplex, it is homotopically trivial. The orientation of $\partial\varphi_k$ dictates a direction along each edge, and hence a direction along each bracketed loop in the composition λ_k . Reversing the orientation of an edge replaces the loop in the composition with its inverse.

Now since $\partial\theta = \alpha$, one of the loops described above must be α itself, with

the vertex paths constant at x_0 . We want to consider the product of all such loops produced in $\partial\theta$, and for clarity we assume that the first loop in the product is α . Write the product of the loops from $\partial\theta$ in the form

$$\eta_1\eta_2\eta_3\cdots\eta_p\alpha$$

and note that the composition is trivial in $\pi_1(X, x_0)$. So

$$\alpha^{-1} = \eta_1\eta_2\eta_3\cdots\eta_p.$$

The algebraic sum of the 1-simplices other than α must be 0 since $\partial\theta = \alpha$. Hence each singular 1-simplex that occurs is expressed in equal numbers with each orientation. This means that $\eta_1\eta_2\eta_3\cdots\eta_p$ is a product of loops in which a loop and its inverse appear an equal number of times. Consequently, $\eta_1\eta_2\eta_3\cdots\eta_p$ must lie in the commutator subgroup, and so must α .

Therefore the kernel of h is contained in the commutator subgroup. Conversely, since $H_1(X, x_0)$ is abelian, the commutator subgroup of $\pi_1(X, x_0)$ is contained in the kernel of h . \square

As a final topic in this chapter, we consider the problem of computing the fundamental group of the union of two spaces in terms of the fundamental groups of each space individually and of their intersection. It has already been observed that the lack of a process analogous to simplicial subdivision makes this problem more difficult than the same question for homology groups. However, the approach we use does involve decomposing a loop into segments contained in one subspace or the other.

So let $X = X_1 \cup X_2$ be the union of two open sets with X_1, X_2 and $X_0 = X_1 \cap X_2$ all nonempty and pathwise connected, with $x_0 \in X_1 \cap X_2$. The inclusion maps of subspaces give rise to the following commutative diagram

$$(4.22) \quad \begin{array}{ccc} \pi_1(X_0, x_0) & \xrightarrow{i_1^*} & \pi_1(X_1, x_0) \\ \downarrow i_2^* & & \downarrow j_1^* \\ \pi_1(X_2, x_0) & \xrightarrow{j_2^*} & \pi_1(X, x_0). \end{array}$$

The first step is to show that $\pi_1(X, x_0)$ satisfies a “universal mapping” property with respect to diagrams of this type.

4.23 Proposition. *If G is a group and k_1 and k_2 are homomorphisms so that the following diagram is commutative*

$$(4.24) \quad \begin{array}{ccc} \pi_1(X_0, x_0) & \xrightarrow{i_1^*} & \pi_1(X_1, x_0) \\ \downarrow i_2^* & & \downarrow k_1 \\ \pi_1(X_2, x_0) & \xrightarrow{k_2} & G \end{array},$$

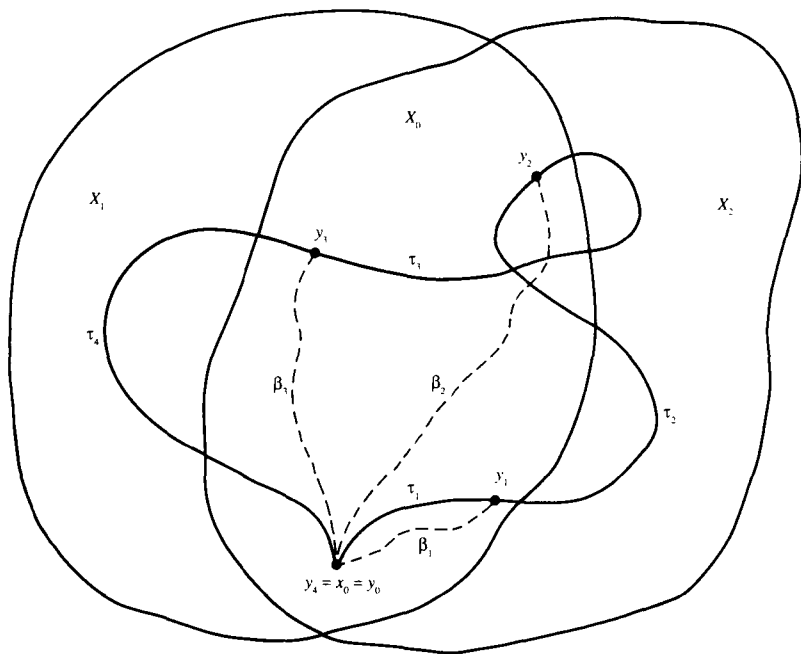

Figure 4.15

then there exists a unique homomorphism

$$\mu: \pi_1(X, x_0) \rightarrow G$$

such that $\mu j_{1*} = k_1$ and $\mu j_{2*} = k_2$.

Proof. Let α be a loop in X at x_0 . Since X_1 and X_2 are open, we can find a finite set of points $x_0 = y_0, y_1, \dots, y_m = x_0$ along α with the property that each y_i lies in X_0 and the segment τ_{i+1} from y_i to y_{i+1} lies in either X_1 or X_2 . For each point y_i select a path β_i in $X_0 = X_1 \cap X_2$ from x_0 to y_i (Figure 4.15).

Note that for each integer $i, 0 < i < m$, there is a loop at x_0 given by traversing β_{i-1} from x_0 to y_{i-1} , τ_i from y_{i-1} to y_i , and then β_i^{-1} from y_i back to x_0 . Call this loop $\theta_i = \beta_i^{-1} \tau_i \beta_{i-1}$. It is clear that θ_i lies entirely within either X_1 or X_2 , hence θ_i represents an element of the respective fundamental group.

Define a function

$$\mu: \pi_1(X, x_0) \rightarrow G$$

by $\mu(\alpha) = k_*(\theta_1) \cdot k_*(\theta_2) \cdots k_*(\theta_m)$, where it is understood that k_* means either k_1 or k_2 depending on whether θ_i lies within X_1 or X_2 . Note that there is some potential ambiguity if θ_i lies in both X_1 and X_2 , but this means θ_i

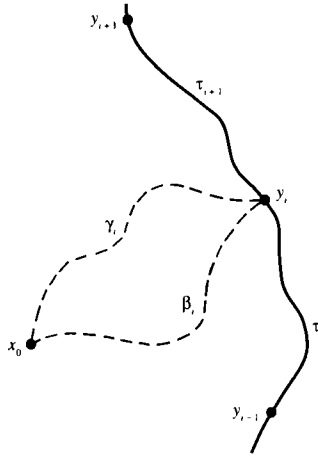

Figure 4.16

arises from X_0 , and the commutativity of (4.24) implies that, in this case, both choices yield the same result.

Although our intuition strongly supports this definition of μ , there are several questions that must be resolved:

- (1) Is this definition of μ independent of the choices of the points y_i and the paths β_i ?
- (2) If α and α' are homotopic loops, is $\mu(\alpha) = \mu(\alpha')$?
- (3) Is μ a homomorphism? Does $\mu j_{1*} = k_1$ and $\mu j_{2*} = k_2$?
- (4) Is μ unique with regard to these properties?

First consider a single point y_i along α , and suppose another path γ_i is chosen in X_0 from x_0 to y_i (Figure 4.16). Note that

$$k_*(\beta_i^{-1}\tau_i\beta_{i-1}) = k_*(\beta_i^{-1}\gamma_i\gamma_i^{-1}\tau_i\beta_{i-1}) = k_*(\beta_i^{-1}\gamma_i) \cdot k_*(\gamma_i^{-1}\tau_i\beta_{i-1}).$$

On the other hand

$$\begin{aligned} k_*(\beta_{i+1}^{-1}\tau_{i+1}\beta_i) &= k_*(\beta_{i+1}^{-1}\tau_{i+1}\gamma_i\gamma_i^{-1}\beta_i) = k_*(\beta_{i+1}^{-1}\tau_{i+1}\gamma_i) \cdot k_*(\gamma_i^{-1}\beta_i) \\ &= k_*(\beta_{i+1}^{-1}\tau_{i+1}\gamma_i) \cdot [k_*(\beta_i^{-1}\gamma_i)]^{-1}. \end{aligned}$$

Since $\beta_i^{-1}\gamma_i$ is a loop in X_0 and since the diagram (4.24) commutes, the value of k_* on this loop will be the same, whether k_* is k_1 or k_2 . Thus

$$k_*(\beta_{i+1}^{-1}\tau_{i+1}\beta_i) \cdot k_*(\beta_i^{-1}\tau_i\beta_{i-1}) = k_*(\beta_{i+1}^{-1}\tau_{i+1}\gamma_i) \cdot k_*(\gamma_i^{-1}\tau_i\beta_{i-1}).$$

So the product will not change when γ_i is used in place of β_i . Repeating this argument at each y_i shows that the product defining $\mu(\alpha)$ is independent of the choice of the paths β_i .

To see that μ is independent of the choice of the points y_i , consider once

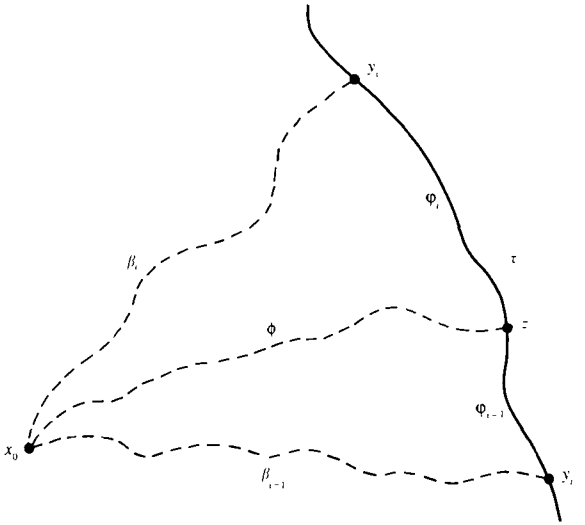

Figure 4.17

again the loop $\beta_i^{-1}\tau_i\beta_{i-1}$. Suppose another point $z \in X_0$ is added along τ_i , separating τ_i into ϕ_i and ϕ_{i-1} , and ϕ is a path in X_0 from x_0 to z (Figure 4.17).

Note that if $\beta_i^{-1}\tau_i\beta_{i-1}$ lies in X_j , then $\beta_i^{-1}\phi_i\phi$ and $\phi^{-1}\phi_{i-1}\beta_{i-1}$ are both contained in X_j , and

$$k_*(\beta_i^{-1}\phi_i\phi) \cdot k_*(\phi^{-1}\phi_{i-1}\beta_{i-1}) = k_*(\beta_i^{-1}\phi_i\phi\phi^{-1}\phi_{i-1}\beta_{i-1}) = k_*(\beta_i^{-1}\tau_i\beta_{i-1}).$$

Thus adding an additional point to the set of $\{y_i\}$ does not change the value of $\mu(\alpha)$. More generally, adding a finite number of points to the set, i.e., refining the $\{y_i\}$, leads to the same result. Now given two distinct sets of choices for the points $\{y_i\}$, we can consider the mesh of the two sets, producing a refinement of both. The corresponding definitions of $\mu(\alpha)$ must agree since they are both equal to the value computed using the refinement. Therefore the definition of $\mu(\alpha)$ is independent of the choice of the points $\{y_i\}$.

Suppose α' is a loop at x_0 homotopic to α .

If $F: [0, 1] \times [0, 1] \rightarrow X$ is a homotopy between α and α' , we can subdivide the unit square so that each small rectangle is mapped by F into either X_1 or X_2 (Figure 4.18). Proceeding one small rectangle at a time, we deform α into α' through a finite sequence of paths such that each step involves a homotopy in which the only change occurs within either X_1 or X_2 . For such a restricted deformation, the points $\{y_i\}$ may be chosen so that the value of μ is unchanged. Hence $\mu(\alpha) = \mu(\alpha')$, and μ is well defined on $\pi_1(X, x_0)$.

It is clear that $\mu j_{1*} = k_1$ and $\mu j_{2*} = k_2$. The verification that μ is a homomorphism of groups and that μ is unique with regard to these properties is left as an exercise. □

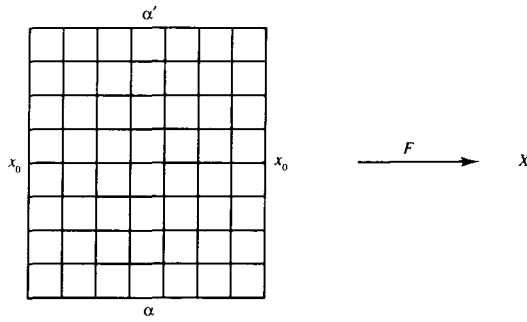

Figure 4.18

This result should be put in more conventional terms. Given a category C and a diagram

$$(4.25) \quad \begin{array}{ccc} C & \xrightarrow{i} & A \\ j \downarrow & & \\ B & & \end{array}$$

of objects and morphisms, a *solution* is an object D and morphisms r and s making the following diagram commute

$$\begin{array}{ccc} C & \xrightarrow{i} & A \\ j \downarrow & & \downarrow r \\ B & \xrightarrow{s} & D. \end{array}$$

A *pushout* of (4.25) is a solution with the universal mapping property described in Proposition 4.23. In other words, it is a solution that admits a unique, compatible morphism to any other solution.

EXAMPLES. (1) In the category of topological spaces and continuous functions, a space X written as the union of two open subsets X_1 and X_2 will produce a diagram of inclusion maps

$$\begin{array}{ccc} X_1 \cap X_2 & \xrightarrow{i} & X_1 \\ j \downarrow & & \\ X_2 & & \end{array}$$

whose pushout is $X_1 \cup X_2$.

(2) Similarly, if Y is a space and $f: S^{n-1} \rightarrow Y$ is a map, the pushout of the diagram

$$\begin{array}{ccc} S^{n-1} & \xrightarrow{i} & D^n \\ \downarrow f & & \\ Y & & \end{array}$$

is the space $Y \cup_f D^n = Y_f$.

(3) In the category of groups and homomorphisms, for any groups A and B there is a diagram

$$\begin{array}{ccc} \{1\} & \longrightarrow & A \\ \downarrow & & \\ B & & \end{array}$$

The pushout of this diagram is called the *free product* of A and B , written $A * B$. One must establish the existence of such a group and of the homomorphisms $A \rightarrow A * B$ and $B \rightarrow A * B$. An element of $A * B$ can be thought of as a *word* (g_1, g_2, \dots, g_m) in A and B , a finite sequence of elements, alternating from one group or the other, with no g_i equal to the identity. The product is defined by juxtaposition followed by coalescence, when appropriate. The identity element in $A * B$ is the empty word. With this characterization the homomorphism r assigns an element $a \in A$ to the word (a) , likewise for the homomorphism s .

More generally, if

$$\begin{array}{ccc} C & \xrightarrow{i} & A \\ \downarrow j & & \\ B & & \end{array}$$

is a diagram of groups and homomorphisms, there exists a pushout G which is the *amalgamated free product* $(A * B)/H$, where H is the normal subgroup of $A * B$ generated by the elements $(i(c), [j(c)]^{-1})$, where $c \in C$. For details see Gray [1973], Massey [1967], or Spanier [1966]. Note that this characterization of $A * B$ and its amalgamation tracks closely the argument used in proving Proposition 4.23.

These observations, together with Proposition 4.23, provide a basic tool for computing fundamental groups.

4.26 Van Kampen Theorem. *If $X = X_1 \cup X_2$ is written as the union of two pathwise connected open sets with $X_1 \cap X_2$ pathwise connected, then*

$$\pi_1(X, x_0) \approx \frac{\pi_1(X_1, x_0) * \pi_1(X_2, x_0)}{H}$$

where H is the normal subgroup generated by the words $(i_{1*}(\alpha), [i_{2*}(\alpha)]^{-1})$ for α in $\pi_1(X_1 \cap X_2, x_0)$.

Proof. Within a given category, once a pushout is shown to exist, it will be unique up to isomorphism. This is a direct result of the existence and uniqueness of a compatible morphism from a pushout to any solution.

The conclusion of Proposition 4.23 may be restated in this setting: A pushout of the diagram

$$\begin{array}{ccc} \pi_1(X_1 \cap X_2, x_0) & \xrightarrow{i_{1*}} & \pi_1(X_1, x_0) \\ \downarrow i_{2*} & & \\ \pi_1(X_2, x_0) & & \end{array}$$

is $\pi_1(X, x_0)$. Applying the observations in the preceding discussion, this must be isomorphic to the amalgamated free product of $\pi_1(X_1, x_0)$ and $\pi_1(X_2, x_0)$. □

4.27 Corollary. *If $X = X_1 \cup X_2$ is the union of pathwise connected open sets and $X_1 \cap X_2$ is both pathwise connected and simply connected, then*

$$\pi_1(X, x_0) \approx \pi_1(X_1, x_0) * \pi_1(X_2, x_0). \quad \square$$

EXAMPLES. (1) Let $X = S_h \vee S_v$ be the join of two circles with common point x_0 , and let X_1 and X_2 be S_v and S_h , each expanded to include a connected open set about x_0 in the other circle (Figure 4.19). Then $X_1 \cap X_2$ is contractible, and (4.27) may be applied to conclude

$$\begin{aligned} \pi_1(X, x_0) &\approx \pi_1(S_v, x_0) * \pi_1(S_h, x_0) \\ &\approx Z * Z, \end{aligned}$$

the free group on two letters. Denote these generating elements by a and b .

(2) Write the torus T^2 as $X_1 \cup X_2$ where X_1 is an open disk on T^2 and X_2 is the complement of a smaller closed disk $D \subseteq X_1$ (Figure 4.20). Then $\pi_1(X_1, x_0) \approx \{1\}$, and $X_1 \cap X_2$ has the homotopy type of a circle. Suppose α is a loop in $X_1 \cap X_2$ generating its fundamental group.

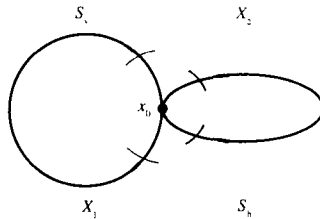

Figure 4.19

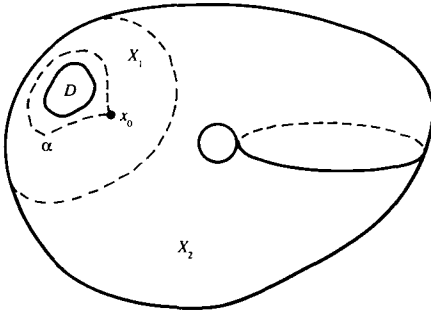

Figure 4.20

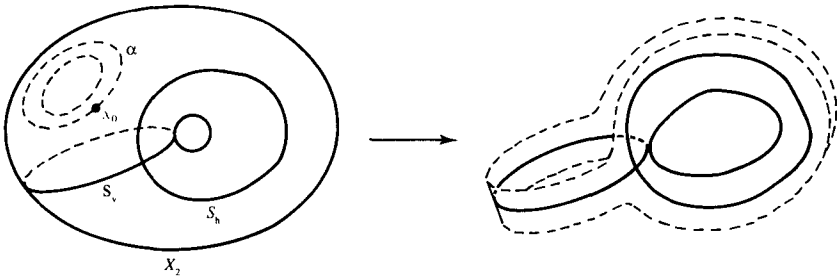

Figure 4.21

The space X_2 may be retracted onto $S_h \vee S_v$ (Figure 4.21). Note that the deformation of X_2 onto $S_h \vee S_v$ carries the generating loop α onto the product $aba^{-1}b^{-1}$ in $\pi_1(X_2, x_0)$. Thus in the isomorphism

$$\pi_1(X, x_0) \approx \frac{\pi_1(X_1, x_0) * \pi_1(X_2, x_0)}{H}$$

the resulting group is

$$\frac{\pi_1(X_2, x_0)}{H} \approx \frac{Z * Z}{H}$$

where H is the normal subgroup generated by $aba^{-1}b^{-1}$. Note that

$$(aba^{-1}b^{-1})ba = ab,$$

in fact H is precisely the commutator subgroup of $Z * Z$. Consequently,

$$\pi_1(X, x_0) \approx Z \oplus Z$$

as we determined previously.

(3) Write $\mathbb{R}P(2)$ as $S^1 \cup_f D^2$, where $f: S^1 \rightarrow S^1$ is a map of degree 2. Let X_1 be the interior of D^2 , and let X_2 be the complement in $\mathbb{R}P(2)$ of the center of

D^2 (Figure 4.22). Then X_1 is contractible, and X_2 retracts onto S^1 ; a generating loop β in $X_1 \cap X_2$ is wrapped twice around S^1 during this retraction. Hence $\pi_1(\mathbb{R}P(2), x_0) \approx (\{1\} * Z)/H$ where H is generated by the square of the generator of the fundamental group of S^1 . Therefore $\pi_1(\mathbb{R}P(2), x_0)$ is cyclic of order 2.

EXERCISE 10. Determine the fundamental group of the Klein Bottle.

EXERCISE 11. Describe the universal covering space of the Klein Bottle.

EXERCISE 12. For any positive integer k , find a topological space whose fundamental group is cyclic of order k .

EXERCISE 13. Determine the fundamental group of $\mathbb{C}P(n)$ for each $n \geq 1$.

EXERCISE 14. If $n > 1$, prove that any continuous function $g: S^n \rightarrow S^1$ is homotopically trivial.

EXERCISE 15. Suppose X is a finite CW complex with no cells of dimension 1. What can you say about the fundamental group of X ?

EXERCISE 16. If X is a finite CW complex of dimension $k > 2$, with one 0-cell, one 1-cell, and no 2-cells, show that $\pi_1(X, x_0)$ is infinite cyclic.

EXERCISE 17. A *knot* is a simple closed curve imbedded in \mathbb{R}^3 . Two knots K_1 and K_2 are said to be *equivalent* if there exists an orientation-preserving homeomorphism

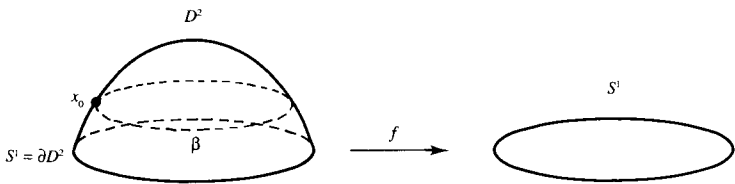

Figure 4.22

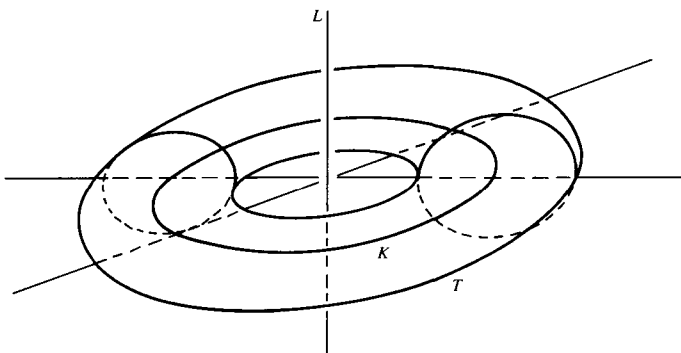

Figure 4.23

$h: \{\mathbb{R}^3 - K_1\} \rightarrow \{\mathbb{R}^3 - K_2\}$. A knot equivalent to an ordinary Euclidean circle in a plane in \mathbb{R}^3 is said to be *unknotted*. The *group of the knot* K is the fundamental group of $\mathbb{R}^3 - K$. Clearly, two equivalent knots have isomorphic groups.

- (a) Considering S^3 as the one point compactification of \mathbb{R}^3 , show that for any knot K , the inclusion $\{\mathbb{R}^3 - K\} \subseteq \{S^3 - K\}$ induces an isomorphism of fundamental groups.
- (b) Consider S^3 as the unit vectors in $\mathbb{C}^2 \approx \mathbb{R}^4$, and take K to be the unit circle in the complex plane determined by the first coordinate

$$K = \{(z_1, z_2) \in S^3 \mid |z_1| = 1\}.$$

This is, by definition, unknotted. Show that the group of this knot is infinite cyclic. This unknotted circle K is the core of a solid torus

$$T_K = \{(z_1, z_2) \in S^3 \mid |z_1|^2 \geq \frac{1}{2}\}.$$

There is an analogous circle

$$L = \{(z_1, z_2) \in S^3 \mid |z_2| = 1\}$$

at the core of the solid torus

$$T_L = \{(z_1, z_2) \in S^3 \mid |z_2|^2 \geq \frac{1}{2}\}.$$

These solid tori intersect in a torus

$$T = T_K \cap T_L = \{(z_1, z_2) \in S^3 \mid |z_1|^2 = \frac{1}{2} \text{ and } |z_2|^2 = \frac{1}{2}\}.$$

It may help to picture T as a standard torus in \mathbb{R}^3 , with core K the unit circle in the (x, y) -plane. In this representation, L would lie along the z -axis (Figure 4.23). Now let N be a knot lying on the torus T that traverses m times in the horizontal (K) direction and n times in the vertical (L) direction. This is a *torus knot of type* (m, n) .

- (c) Use Van Kampen's Theorem to show that the group of this knot is isomorphic to $(Z * Z)/H$, where H is the normal subgroup generated by (a^m, b^n) , a and b the generators arising from K and L .

CHAPTER 5

Products

In this chapter we introduce the theory of products in homology and cohomology. Following the Künneth formula for free chain complexes, we state and prove the acyclic model theorem. This is applied to establish the Eilenberg–Zilber theorem and the resulting external products in homology and cohomology. When the coefficient group is a ring R , it is shown that the cohomology external product may be refined to the cup product, giving the cohomology group the structure of an R -algebra. This structure is computed for the torus by introducing the Alexander–Whitney diagonal approximation. Also, a cup product definition of the Hopf invariant is given. Finally, the cap product between homology and cohomology is defined in anticipation of Chapter 6.

Suppose that $C = \{C_n, \partial\}$ and $D = \{D_n, \partial\}$ are chain complexes. In Chapter 3 we discussed the formation of a new chain complex by tensoring a given chain complex with an abelian group. We now want to generalize this to give a procedure for tensoring two chain complexes to form a new chain complex.

Define a chain complex $C \otimes D$ by setting

$$(C \otimes D)_n = \sum_k C_k \otimes D_{n-k}.$$

The boundary operator on a direct summand

$$\partial: C_p \otimes D_q \rightarrow C_{p-1} \otimes D_q \oplus C_p \otimes D_{q-1}$$

is given by the formula

$$\partial(c \otimes d) = \partial c \otimes d + (-1)^p c \otimes \partial d.$$

To check that this gives a chain complex, note that

$$\begin{aligned}
\partial(\partial(c \otimes d)) &= \partial(\partial c \otimes d + (-1)^p c \otimes \partial d) \\
&= \partial\partial c \otimes d + (-1)^{p-1} \partial c \otimes \partial d + (-1)^p \partial c \otimes \partial d \\
&\quad + (-1)^{2p} (c \otimes \partial\partial d) \\
&= 0.
\end{aligned}$$

Since the elements $(c \otimes d)$ generate $C \otimes D$, it follows that $\partial \circ \partial = 0$.

Note that if $f: C \rightarrow C'$ and $g: D \rightarrow D'$ are chain maps between chain complexes, there is an associated chain map

$$f \otimes g: C \otimes D \rightarrow C' \otimes D'$$

characterized by $f \otimes g(c \otimes d) = f(c) \otimes g(d)$.

Now suppose that C is a free chain complex. The exact sequence

$$0 \rightarrow Z_n(C) \xrightarrow{\alpha} C_n \xrightarrow{\hat{c}} B_{n-1}(C) \rightarrow 0,$$

where α is the inclusion, must split because $B_{n-1}(C)$ is free. Thus, there exists a homomorphism

$$\phi: C_n \rightarrow Z_n(C)$$

which is just projection onto a direct summand, that is, $\phi \circ \alpha = \text{identity on } Z_n(C)$.

We consider the graded groups $Z_*(C)$, $B_*(C)$, and $H_*(C)$ to be chain complexes in which the boundary operators are all identically zero. Denote by Φ the composition $\Phi = \pi \circ \phi$,

$$C_n \xrightarrow{\phi} Z_n(C) \xrightarrow{\pi} H_n(C),$$

where π is the quotient map. Then Φ is a chain map between chain complexes because

$$\Phi(\partial c) = \pi(\partial c) = 0 = \partial\Phi(c).$$

5.1 Theorem. *If C and D are free chain complexes, the chain map*

$$\Phi \otimes \text{id}: C \otimes D \rightarrow H_*(C) \otimes D$$

induces an isomorphism

$$(\Phi \otimes d)_*: H_n(C \otimes D) \rightarrow H_n(H_*(C) \otimes D).$$

Proof. Recall the exact sequence of chain complexes and chain maps

$$0 \rightarrow Z_*(C) \xrightarrow{\alpha} C \xrightarrow{\hat{c}} B_*(C) \rightarrow 0,$$

where \hat{c} has degree -1 . Since the sequence splits, we may tensor with the chain complex D and preserve exactness. This yields an exact sequence of chain complexes and chain maps

$$0 \rightarrow Z_*(C) \otimes D \xrightarrow{\alpha \otimes \text{id}} C \otimes D \xrightarrow{\hat{c} \otimes \text{id}} B_*(C) \otimes D \rightarrow 0$$

and thus an exact homology sequence

$$\begin{aligned} \cdots \rightarrow H_n(Z_*(C) \otimes D) \xrightarrow{(\alpha \otimes \text{id})_*} H_n(C \otimes D) \xrightarrow{(\hat{r} \otimes \text{id})_*} H_{n-1}(B_*(C) \otimes D) \\ \xrightarrow{\Delta} H_{n-1}(Z_*(C) \otimes D) \rightarrow \cdots, \end{aligned}$$

where $(\hat{r} \otimes \text{id})_*$ has degree -1 and Δ is the connecting homomorphism.

On the other hand, the short exact sequence

$$0 \rightarrow B_*(C) \xrightarrow{\beta} Z_*(C) \xrightarrow{\pi} H_*(C) \rightarrow 0$$

of chain complexes need not split. However, since D is free, exactness will be preserved in

$$0 \rightarrow B_*(C) \otimes D \xrightarrow{\beta \otimes \text{id}} Z_*(C) \otimes D \xrightarrow{\pi \otimes \text{id}} H_*(C) \otimes D \rightarrow 0.$$

Passing to the homology groups of these complexes we have the long exact sequence

$$\begin{aligned} \cdots \rightarrow H_n(B_*(C) \otimes D) \xrightarrow{(\beta \otimes \text{id})_*} H_n(Z_*(C) \otimes D) \xrightarrow{(\pi \otimes \text{id})_*} H_n(H_*(C) \otimes D) \\ \xrightarrow{\Delta'} H_{n-1}(B_*(C) \otimes D) \rightarrow \cdots. \end{aligned}$$

These two long exact sequences

$$\begin{array}{ccccc} H_n(B_*(C) \otimes D) & \xrightarrow{\Delta} & H_n(Z_*(C) \otimes D) & \xrightarrow{(\alpha \otimes \text{id})_*} & H_n(C \otimes D) \\ \downarrow = & & \downarrow = & & \downarrow (\Phi \otimes \text{id})_* \\ H_n(B_*(C) \otimes D) & \xrightarrow{(\beta \otimes \text{id})_*} & H_n(Z_*(C) \otimes D) & \xrightarrow{(\pi \otimes \text{id})_*} & H_n(H_*(C) \otimes D) \\ \xrightarrow{(\hat{r} \otimes \text{id})_*} & & \xrightarrow{\Delta} & & \\ H_{n-1}(B_*(C) \otimes D) & & H_{n-1}(Z_*(C) \otimes D) & & \\ \downarrow = & & \downarrow = & & \\ \xrightarrow{\Delta'} & & \xrightarrow{(\beta \otimes \text{id})_*} & & \\ H_{n-1}(B_*(C) \otimes D) & & H_{n-1}(Z_*(C) \otimes D) & & \end{array}$$

may be related in such a way that each rectangle commutes up to sign (see the following exercise). Now the proof of the five lemma (Exercise 4, Chapter 2) only required commutativity up to sign; hence, we apply the five lemma to conclude that

$$(\Phi \otimes \text{id})_*: H_n(C \otimes D) \xrightarrow{\cong} H_n(H_*(C) \otimes D)$$

is an isomorphism. This completes the proof. □

EXERCISE 1. Show that in the diagram in the preceding proof each rectangle commutes up to sign.

This proposition reduces the problem of computing the homology of the chain complex $C \otimes D$ to computing the homology of the simpler complex

$H_*(C) \otimes D$. Note that if $c \otimes d \in H_p(C) \otimes D_q$, then $\partial(c \otimes d) = (-1)^p c \otimes \partial d$, so that up to sign the boundary operator is just

$$\text{id} \otimes \partial: H_p(C) \otimes D_q \rightarrow H_p(C) \otimes D_{q-1}.$$

Therefore, for p fixed $H_p(C) \otimes D$ is a subcomplex of $H_*(C) \otimes D$, in fact a direct summand, and we conclude that

$$H_n(H_*(C) \otimes D) = \sum_p H_n(H_p(C) \otimes D).$$

Now if two boundary operators differ by sign only, it is evident that they produce the same homology groups. Thus, we may assume that the boundary operator in the chain complex $H_p(C) \otimes D$ is $\text{id} \otimes \partial$. Note that the n -dimensional component of this complex is $H_p(C) \otimes D_{n-p}$.

Since D is a free chain complex, we are in a position to apply the universal coefficient theorem, Theorem 3.6, to the chain complex $H_p(C) \otimes D$. Thus

$$H_n(H_p(C) \otimes D) \approx H_p(C) \otimes H_{n-p}(D) \oplus \text{Tor}(H_p(C), H_{n-p-1}(D)).$$

Summing these over all values of p , we have completed the proof of the *Künneth formula* for free chain complexes:

5.2 Corollary. *If C and D are free chain complexes, then*

$$H_n(C \otimes D) \approx \sum_{p+q=n} H_p(C) \otimes H_q(D) \oplus \sum_{r+s=n-1} \text{Tor}(H_r(C), H_s(D)). \quad \square$$

EXAMPLE. Suppose $c \in Z_p(C)$ but c is not a boundary. Suppose further that $r \cdot c = \partial c'$ for some $c' \in C_{p+1}$ and some minimal integer $r > 0$, so that c represents a homology class of order r . Similarly let $d \in Z_q(D)$ represent a homology class of order r so that $rd = \partial d'$ for some $d' \in D_{q+1}$. Then in $(C \otimes D)_{p+q+1}$ the element $(c' \otimes d - (-1)^p c \otimes d')$ is a cycle because

$$\begin{aligned} \partial(c' \otimes d - (-1)^p c \otimes d') &= \partial c' \otimes d + (-1)^{p+1} c' \otimes \partial d - (-1)^p \partial c \otimes d' \\ &\quad - (-1)^{2p} c \otimes \partial d' \\ &= rc \otimes d - c \otimes rd \\ &= r(c \otimes d - c \otimes d) \\ &= 0. \end{aligned}$$

In this way torsion common to $H_p(C)$ and $H_q(D)$ produces homology classes in $H_{p+q+1}(C \otimes D)$.

Given spaces X and Y , the Künneth formula of Corollary 5.2 may be applied to the singular chain complexes $S_*(X)$ and $S_*(Y)$ to give the isomorphism

$$H_n(S_*(X) \otimes S_*(Y)) \approx \sum_{p+q=n} H_p(X) \otimes H_q(Y) \oplus \sum_{r+s=n-1} \text{Tor}(H_r(X), H_s(Y)).$$

We turn now to the problem of relating $H_n(S_*(X) \otimes S_*(Y))$ to $H_n(X \times Y)$, the homology of the cartesian product of X and Y .

The solution of this problem will be stated in terms of the acyclic model theorem, a useful tool in homological algebra. To put this result in its proper setting we require a number of definitions. A *category* \mathcal{C} is

- (a) a class of *objects*,
- (b) for every ordered pair of objects a set $\text{hom}(X, Y)$, of *morphisms* viewed as functions with domain X and range Y ,

such that whenever $f: X \rightarrow Y$ and $g: Y \rightarrow Z$ are morphisms, there is an element $g \circ f$ in $\text{hom}(X, Z)$. These are required to satisfy the following axioms:

1. *Associativity*: $(h \circ g) \circ f = h \circ (g \circ f)$.
2. *Identity*: For every object Y there is an element $1_Y \in \text{hom}(Y, Y)$ such that if $f: X \rightarrow Y$ and $g: Y \rightarrow Z$ are morphisms, then $1_Y \circ f = f$ and $g \circ 1_Y = g$.

EXAMPLES. (i) The category whose objects are sets and whose morphisms are functions.

(ii) The category of abelian groups and homomorphisms.

(iii) The category of topological spaces and continuous functions.

(iv) The category of pairs of spaces and maps of pairs.

(v) The category of chain complexes and chain maps.

If \mathcal{C} and \mathcal{D} are categories, a *covariant functor* $T: \mathcal{C} \rightarrow \mathcal{D}$ is a function that assigns to each object X in \mathcal{C} an object $T(X)$ in \mathcal{D} and to each morphism $f: X \rightarrow Y$ a morphism $T(f): T(X) \rightarrow T(Y)$ such that

- (a) $T(1_Y) = 1_{T(Y)}$,
- (b) $T(f \circ g) = T(f) \circ T(g)$.

A functor K is *contravariant* if for $f: X \rightarrow Y$, $K(f): K(Y) \rightarrow K(X)$ and

- (a') $K(1_Y) = 1_{K(Y)}$,
- (b') $K(f \circ g) = K(g) \circ K(f)$.

EXAMPLES. (1) The correspondence $(X, A) \rightarrow S_*(X, A)$ and $[f: (X, A) \rightarrow (Y, B)] \rightarrow [f_\#: S_*(X, A) \rightarrow S_*(Y, B)]$ is a covariant functor from Category (iv) above to Category (v).

(2) The correspondence $X \rightarrow H^n(X; G)$ and $[f: X \rightarrow Y] \rightarrow [f^*: H^n(Y; G) \rightarrow H^n(X; G)]$ is a contravariant functor from Category (iii) to Category (ii).

Suppose that \mathcal{C} and \mathcal{D} are categories and $T_1, T_2: \mathcal{C} \rightarrow \mathcal{D}$ are covariant functors. A *natural transformation* $\tau: T_1 \rightarrow T_2$ is a function which assigns to each object X in \mathcal{C} a morphism $\tau(X): T_1(X) \rightarrow T_2(X)$ in \mathcal{D} such that commutativity holds in

$$\begin{array}{ccc}
 T_1(X) & \xrightarrow{T_1(f)} & T_1(Y) \\
 \downarrow \tau(X) & & \downarrow \tau(Y) \\
 T_2(X) & \xrightarrow{T_2(f)} & T_2(Y)
 \end{array}$$

whenever $f: X \rightarrow Y$ is a morphism in \mathcal{C} .

Now fix a category \mathcal{C} . Suppose that $\mathcal{M} = \{M_\alpha\}_{\alpha \in \Lambda}$ is a specified collection of objects in \mathcal{C} . \mathcal{M} will be called the *models* of \mathcal{C} . A functor T from \mathcal{C} to the category of abelian groups and homomorphisms is *free with respect to the models* \mathcal{M} if there exists an element $e_\alpha \in T(M_\alpha)$ for each α such that for every X in \mathcal{C} the set

$$\{T(f)(e_\alpha) \mid \alpha \in \Lambda, f \in \text{hom}(M_\alpha, X)\}$$

is a basis for $T(X)$ as a free abelian group. A functor T from \mathcal{C} to the category of graded abelian groups is free with respect to the models \mathcal{M} if each T_n is, where T_n is the n th component of T .

5.3 Theorem (Acyclic Model Theorem). *Let \mathcal{C} be a category with models \mathcal{M} and T, T' covariant functors from \mathcal{C} to the category of chain complexes and chain maps, such that $T_n = 0 = T'_n$ for $n < 0$ and T is free with models \mathcal{M} . Suppose further that $H_i(T'(M_\alpha)) = 0$ for $i > 0$ and $M_\alpha \in \mathcal{M}$. If there is a natural transformation*

$$\Phi: H_0(T) \rightarrow H_0(T'),$$

then there is a natural transformation

$$\phi: T \rightarrow T'$$

which induces Φ , and furthermore any two such ϕ are naturally chain homotopic.

Proof. By the hypothesis $T_0(M_\alpha)$ and $T'_0(M_\alpha)$ are the respective cycle groups in dimension zero. Thus, there are epimorphisms π and π' onto the homology groups:

$$\begin{array}{ccc}
 T_0(M_\alpha) & \xrightarrow{\pi} & H_0(T(M_\alpha)) \\
 \downarrow \phi & & \downarrow \Phi \\
 T'_0(M_\alpha) & \xrightarrow{\pi'} & H_0(T'(M_\alpha))
 \end{array}$$

Since T_0 is free with models \mathcal{M} , there is for each α a prescribed element $e_\alpha^0 \in T_0(M_\alpha)$. So for each α we choose an element $\phi(e_\alpha^0) \in T'_0(M_\alpha)$ such that $\pi' \circ \phi(e_\alpha^0) = \Phi \circ \pi(e_\alpha^0)$.

Let $f: M_\alpha \rightarrow X$ be a morphism in \mathcal{C} . Then $T(f)(e_\alpha^0)$ is a basis element in

$T_0(X)$ and we define $\phi(T(f)(e_\alpha^0)) = T'(f)(\phi(e_\alpha^0))$. This defines ϕ on the basis elements of the free abelian group $T_0(X)$ so there is a unique extension to a homomorphism

$$\phi: T_0(X) \rightarrow T'_0(X).$$

To check that ϕ induces the original Φ on zero-dimensional homology, we must show that the front face of the following diagram commutes:

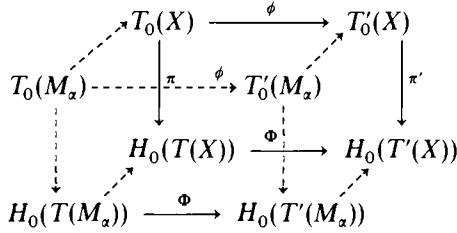

The bottom face commutes by the naturality of Φ . The left and right faces commute since $T(f)$ and $T'(f)$ are chain maps. The back face and the top face commute by definition; thus, the front face must also commute.

Since T_1 is free with models \mathcal{M} , there is for each α a prescribed element $e_\alpha^1 \in T_1(M_\alpha)$. From the above, $\phi(\partial e_\alpha^1)$ is a well defined element of $T'_0(M_\alpha)$. Moreover, since ϕ induces Φ on zero-dimensional homology, $\phi(e_\alpha^1)$ must be a boundary in $T'_0(M_\alpha)$. So let $c \in T'_1(M_\alpha)$ with $\partial c = \phi(\partial e_\alpha^1)$ and define $\phi(e_\alpha^1) = c$. Using the above technique we extend ϕ to a homomorphism $\phi: T_1(X) \rightarrow T'_1(X)$ for each object X in \mathcal{C} .

Suppose ϕ is defined in dimensions less than n , and consider the set $\{e_\alpha^n | e_\alpha^n \in T_n(M_\alpha)\}$ given by the fact that T_n is free with models \mathcal{M} . By the inductive hypothesis $\phi(\partial e_\alpha^n)$ is a well-defined element of $T'_{n-1}(M_\alpha)$. Since it is a cycle and T' is acyclic in positive dimensions, it is also a boundary. So define $\phi(e_\alpha^n)$ to be an element of $T'_n(M_\alpha)$ whose boundary is $\phi(\partial e_\alpha^n)$. Once again ϕ may be extended using the fact that T is free with models \mathcal{M} . This defines ϕ on $T(X)$ for all objects X in \mathcal{C} .

EXERCISE 2. Show that for each X in \mathcal{C} , $\phi: T(X) \rightarrow T'(X)$ is a chain map, and for each morphism $f: X \rightarrow Y$, $\phi \circ T(f) = T'(f) \circ \phi$.

This defines the natural transformation $\phi: T \rightarrow T'$. Suppose now that $\phi': T \rightarrow T'$ is another such natural transformation, inducing Φ on zero-dimensional homology. For each object X in \mathcal{C} we must construct a chain homotopy $\mathcal{T}: T(X) \rightarrow T'(X)$, which is natural with respect to morphisms in \mathcal{C} , having

$$\partial \mathcal{T} + \mathcal{T} \partial = \phi - \phi'.$$

We define \mathcal{T} inductively. Suppose that it has been defined in dimensions less than n , and recall that $T_n(X)$ has basis $\{T(f)(e_\alpha^n)\}$ as a free abelian group. For $n > 0$ the element

$$\phi(e_x^n) - \phi'(e_x^n) - \mathcal{T}(\partial e_x^n)$$

is a cycle because

$$\begin{aligned} \partial\phi(e_x^n) - \partial\phi'(e_x^n) - \partial\mathcal{T}(\partial e_x^n) &= \phi\partial e_x^n - \phi'\partial e_x^n - (-\mathcal{T}\partial\partial e_x^n + \phi\partial e_x^n - \phi'\partial e_x^n) \\ &= 0. \end{aligned}$$

Since T' is acyclic in positive dimensions, this cycle must bound, so define $\mathcal{T}(e_x^n)$ to be an element of $T_{n+1}(M_a)$ whose boundary is $(\phi(e_x^n) - \phi'(e_x^n) - \mathcal{T}(\partial e_x^n))$. Again we extend \mathcal{T} to be defined on $T(X)$ for all objects X in \mathcal{C} by using the fact that T is free with models \mathfrak{M} . This same technique will work for the case $n = 0$ because the cycle $\phi(e_x^0) - \phi'(e_x^0)$ must bound. This is a consequence of the fact that ϕ and ϕ' induce the same homomorphism (Φ) on zero-dimensional homology.

This \mathcal{T} gives the desired chain homotopy and is natural with respect to morphisms of \mathcal{C} , so the proof is complete. \square

Note: The technique in the proof of Theorem 5.3 is essentially the same as that used in Theorem 1.10 and Appendix I, although the former is in a more general context.

EXERCISE 3. Reprove Theorem 1.10 as a corollary to the acyclic model theorem.

We now want to apply this theorem to relate the homology of the chain complex $S_*(X \times Y)$ to the homology of $S_*(X) \otimes S_*(Y)$. Let \mathcal{C} be the category of topological spaces and continuous functions. (This may easily be generalized to the category of pairs of spaces and maps of pairs.) Denote by $\mathcal{C} \times \mathcal{C}$ the category whose objects are ordered pairs (X, Y) of objects in \mathcal{C} and whose morphisms are ordered pairs (f, f') of morphisms in \mathcal{C} with, $f: X \rightarrow X'$ and $f': Y \rightarrow Y'$. Let \mathcal{M} be the set of all pairs (σ^p, σ^q) , $p, q \geq 0$ in $\mathcal{C} \times \mathcal{C}$ where σ^k is the standard k -simplex. Define two functors from $\mathcal{C} \times \mathcal{C}$ to the category of chain complexes and chain maps by

$$T(X, Y) = S_*(X \times Y) \quad \text{and} \quad T'(X, Y) = S_*(X) \otimes S_*(Y).$$

Both of these functors are free with models \mathcal{M} . Furthermore, both have models acyclic in positive dimensions.

The path components of $X \times Y$ are of the form $C \times D$, where C and D are path components of X and Y , respectively. As a result there is a natural isomorphism

$$H_0(X \times Y) \xrightarrow{\Phi} H_0(S_*(X) \otimes S_*(Y))$$

because $H_0(S_*(X) \otimes S_*(Y)) \approx H_0(X) \otimes H_0(Y)$ by the Künneth formula of Corollary 5.2.

From the natural transformations Φ and Φ^{-1} we apply the acyclic model theorem, Theorem 5.3, in each direction to conclude that there exist chain maps

$$\bar{\phi}: S_*(X \times Y) \rightarrow S_*(X) \otimes S_*(Y)$$

and

$$\bar{\phi}: S_*(X) \otimes S_*(Y) \rightarrow S_*(X \times Y)$$

that induce Φ and Φ^{-1} , respectively, in dimension zero.

Thus, $\phi \circ \bar{\phi}$ is a chain map from $S_*(X) \otimes S_*(Y)$ to itself inducing the identity on zero-dimensional homology. But the identity chain map also has this property, so by Theorem 4.3, $\phi \circ \bar{\phi}$ is chain homotopic to the identity. Similarly the composition $\bar{\phi} \circ \phi$ is chain homotopic to the identity on $S_*(X \times Y)$. Therefore

$$\phi_*: H_*(X \times Y) \rightarrow H_*(S_*(X) \otimes S_*(Y))$$

is an isomorphism with inverse $\bar{\phi}_*$. This completes the proof of the *Eilenberg–Zilber theorem*:

5.4 Theorem. *For any spaces X and Y and any integer k there is an isomorphism*

$$\phi_*: H_k(X \times Y) \rightarrow H_k(S_*(X) \otimes S_*(Y)). \quad \square$$

By combining Theorem 5.4 and Corollary 5.2 we have established the Künneth formula for singular homology theory:

5.5 Theorem. *If X and Y are spaces, there is a natural isomorphism*

$$H_n(X \times Y) \approx \sum_{p+q=n} H_p(X) \otimes H_q(Y) \oplus \sum_{r+s=n-1} \text{Tor}(H_r(X), H_s(Y))$$

for each n . □

Suppose now that we have fixed a natural chain map

$$\phi: S_*(X \times Y) \rightarrow S_*(X) \otimes S_*(Y)$$

for any spaces X and Y with the above properties. The composition

$$H_p(X) \otimes H_q(Y) \rightarrow H_{p+q}(S_*(X) \otimes S_*(Y)) \xrightarrow{\phi_*^{-1}} H_{p+q}(X \times Y),$$

where the first homomorphism takes $\{x\} \otimes \{y\}$ into $\{x \otimes y\}$, is called the *homology external product*. The image of $\{x\} \otimes \{y\}$ under the composition is usually denoted $\{x\} \times \{y\}$. From the Künneth formula we may conclude that this is a monomorphism for any choice of p and q . In fact the Künneth formula for singular homology may be restated as a split exact sequence

$$0 \rightarrow \sum_{p+q=n} H_p(X) \otimes H_q(Y) \rightarrow H_n(X \times Y) \rightarrow \sum_{r+s=n-1} \text{Tor}(H_r(X), H_s(Y)) \rightarrow 0,$$

where the monomorphism is given by the external product.

Our primary purpose now is to construct the analog of this in cohomology, that is, a product

$$H^p(X; G_1) \otimes H^q(Y; G_2) \rightarrow H^{p+q}(X \times Y; G_1 \otimes G_2).$$

If $\alpha \in S^p(X; G_1)$ and $\beta \in S^q(Y; G_2)$, then $\alpha: S_p(X) \rightarrow G_1$ and $\beta: S_q(Y) \rightarrow G_2$ are homomorphisms. Denote by $\alpha \times \beta$ the homomorphism given by the composition

$$S_{p+q}(X \times Y) \xrightarrow{\phi} S_*(X) \otimes S_*(Y) \xrightarrow{\alpha \otimes \beta} G_1 \otimes G_2,$$

where $\alpha \otimes \beta$ is defined to be zero on any term not lying in $S_p(X) \otimes S_q(Y)$. Thus, $\alpha \times \beta \in S^{p+q}(X \times Y; G_1 \otimes G_2)$. This defines an external product on cochains

$$S^p(X; G_1) \otimes S^q(Y; G_2) \rightarrow S^{p+q}(X \times Y; G_1 \otimes G_2).$$

5.6 Proposition. *If $\alpha \in S^p(X; G_1)$ and $\beta \in S^q(Y; G_2)$ are cochains and $\alpha \times \beta \in S^{p+q}(X \times Y; G_1 \otimes G_2)$ is their external product, then*

$$\delta(\alpha \times \beta) = (\delta\alpha) \times \beta + (-1)^p \alpha \times \delta\beta.$$

(This is the derivation formula for cochains.)

Proof. The diagram

$$\begin{array}{ccccc} S_{p+q+1}(X \times Y) & \xrightarrow{\phi} & S_*(X) \otimes S_*(Y) & & \\ \downarrow \partial & & \downarrow \partial & & \\ S_{p+q}(X \times Y) & \xrightarrow{\phi} & S_*(X) \otimes S_*(Y) & \xrightarrow{\alpha \otimes \beta} & G_1 \otimes G_2 \end{array}$$

commutes since ϕ is a chain map. Thus

$$\delta(\alpha \times \beta) = (\alpha \otimes \beta \circ \phi) \circ \partial = (\alpha \otimes \beta) \circ \partial \circ \phi.$$

On the other hand

$$(\delta\alpha) \times \beta = ((\delta\alpha) \otimes \beta) \circ \phi \quad \text{and} \quad \alpha \times \delta\beta = (\alpha \otimes \delta\beta) \circ \phi.$$

Therefore, it is sufficient to check the behavior of these three homomorphisms on the image of ϕ .

Let $e \otimes c$ be a basis element of $S_*(X) \otimes S_*(Y)$. Then $(\alpha \otimes \beta) \circ \partial$ will be zero on $e \otimes c$ unless

- (i) $e \in S_{p+1}(X)$ and $c \in S_q(Y)$ or
- (ii) $e \in S_p(X)$ and $c \in S_{q+1}(Y)$.

In the first case

$$\begin{aligned} (\alpha \otimes \beta) \circ \partial(e \otimes c) &= (\alpha \otimes \beta)(\partial e \otimes c + (-1)^{p+1} e \otimes \partial c) \\ &= \alpha(\partial e) \otimes \beta(c) + 0 \\ &= ((\delta\alpha) \otimes \beta)(e \otimes c). \end{aligned}$$

In the second case

$$\begin{aligned}
(\alpha \otimes \beta) \circ \partial(e \otimes c) &= (\alpha \otimes \beta)(\partial e \otimes c + (-1)^p e \otimes \partial c) \\
&= (-1)^p \alpha(e) \otimes \beta(\partial c) \\
&= (-1)^p (\alpha \otimes \delta \beta)(e \otimes c).
\end{aligned}$$

Since all three homomorphisms will be zero on any basis element not of the form (i) or (ii), we conclude that $\delta(\alpha \times \beta) = (\delta\alpha) \times \beta + (-1)^p (\alpha \times \delta\beta)$. \square

5.7 Corollary. *This induces a well-defined external product on cohomology groups*

$$H^p(X; G_1) \otimes H^q(Y; G_2) \rightarrow H^{p+q}(X \times Y; G_1 \otimes G_2)$$

given by $\{\alpha\} \times \{\beta\} = \{\alpha \times \beta\}$.

Proof. This will follow immediately from three consequences of Proposition 5.6:

- (a) cocycle \times cocycle is a cocycle;
- (b) cocycle \times coboundary is a coboundary;
- (c) coboundary \times cocycle is a coboundary.

If $\delta\alpha = 0 = \delta\beta$, then $\delta(\alpha \times \beta) = (\delta\alpha) \times \beta + (-1)^p \alpha \times \delta\beta = 0$. This establishes (a); (b) and (c) follow in similar fashion. \square

The product given by Corollary 5.3 is the *cohomology external product*.

EXERCISE 4. If $f: X' \rightarrow X$ and $g: Y' \rightarrow Y$ are maps, $\{\alpha\} \in H^p(X; G_1)$, and $\{\beta\} \in H^q(Y; G_2)$, show that

$$(f \times g)^*(\{\alpha\} \times \{\beta\}) = f^*\{\alpha\} \times g^*\{\beta\}$$

in $H^{p+q}(X' \times Y'; G_1 \otimes G_2)$.

Let R be an associative commutative ring with unit. So there is a homomorphism $\mu: R \otimes R \rightarrow R$ given by $\mu(a \otimes b) = ab$. We now specialize the cohomology external product to the case where $G_1 = R = G_2$. For $\alpha \in S^p(X; R)$ and $\beta \in S^q(Y; R)$ define $\alpha \times_1 \beta \in S^{p+q}(X \times Y; R)$ to be the composition

$$S_{p+q}(X \times Y) \xrightarrow{\phi} S_*(X) \otimes S_*(Y) \xrightarrow{\alpha \otimes \beta} R \otimes R \xrightarrow{\mu} R.$$

As before this induces a well-defined product on cohomology groups

$$H^p(X; R) \otimes H^q(Y; R) \rightarrow H^{p+q}(X \times Y; R)$$

by taking $\{\alpha\} \otimes \{\beta\}$ into $\{\alpha \times_1 \beta\}$.

5.8 Lemma. *Let $\{\alpha\} \in H^p(X; R)$ and $\{\beta\} \in H^q(Y; R)$ and define the map $T: X \times Y \rightarrow Y \times X$ by $T(x, y) = (y, x)$. Then*

$$T^*: H^{p+q}(Y \times X; R) \rightarrow H^{p+q}(X \times Y; R)$$

has

$$T^*(\{\beta\} \times_1 \{\alpha\}) = (-1)^{pq}(\{\alpha\} \times_1 \{\beta\}).$$

Proof. Define $T': S_*(X) \otimes S_*(Y) \rightarrow S_*(Y) \otimes S_*(X)$ on a basis element $e \otimes c$, where $e \in S_p(X)$ and $c \in S_q(Y)$, by

$$T'(e \otimes c) = (-1)^{pq}c \otimes e.$$

Then consider the diagram

$$\begin{array}{ccccc} S_*(X \times Y) & \xrightarrow{\phi} & S_*(X) \otimes S_*(Y) & \xrightarrow{(-1)^{pq}\alpha \otimes \beta} & R \otimes R & \xrightarrow{\mu} & R. \\ \downarrow T_* & & \downarrow T' & & & & \\ S_*(Y \times X) & \xrightarrow{\phi} & S_*(Y) \otimes S_*(X) & \xrightarrow{\beta \otimes \alpha} & & & \end{array}$$

It is evident that $(-1)^{pq}\mu \circ (\alpha \otimes \beta) = \mu \circ (\beta \otimes \alpha) \circ T'$ since R is commutative. Restricting our attention to the rectangle, we observe that the composition $\phi \circ T_*$ is a chain map, since both ϕ and T_* are chain maps. We also claim that $T' \circ \phi$ is a chain map. To establish this it is sufficient to show that T' is a chain map, so let $e \in S_p(X)$ and $c \in S_q(Y)$. Then

$$\begin{aligned} T' \circ \partial(e \otimes c) &= T'(\partial e \otimes c + (-1)^pe \otimes \partial c) \\ &= (-1)^{(p-1)q}c \otimes \partial e + (-1)^{p+q} \partial c \otimes e \\ &= (-1)^{(p-1)q}c \otimes \partial e + (-1)^{pq} \partial c \otimes e. \end{aligned}$$

On the other hand

$$\begin{aligned} \partial \circ T'(e \otimes c) &= \partial((-1)^{pq}c \otimes e) \\ &= (-1)^{pq} \partial c \otimes e + (-1)^{pq+q}c \otimes \partial e \\ &= (-1)^{pq} \partial c \otimes e + (-1)^{(p+1)q}c \otimes \partial e. \end{aligned}$$

Since these two expressions are equal, we conclude that T' is a chain map.

Now if we check on zero-dimensional homology, it is evident that $T' \circ \phi$ and $\phi \circ T_*$ induce the same transformation. By applying the acyclic model theorem, Theorem 5.3, we conclude that these two chain maps are naturally chain homotopic. Therefore, the cohomology class represented by the composition $\mu \circ (\beta \otimes \alpha) \circ \phi \circ T_*$ is the same as the class represented by $(-1)^{pq}\mu \circ (\alpha \otimes \beta) \circ \phi$. In other words

$$T^*(\{\beta\} \times_1 \{\alpha\}) = (-1)^{pq}\{\alpha\} \times_1 \{\beta\}. \quad \square$$

5.9 Lemma. If $\{\alpha\} \in H^*(X; R)$ and $\{\beta\} \in H^*(Y; R)$ and $f: X' \rightarrow X$, $g: Y' \rightarrow Y$ are maps, then

$$(f \times g)^*(\{\alpha\} \times_1 \{\beta\}) = f^*\{\alpha\} \times_1 g^*\{\beta\}.$$

Proof. This follows routinely as in Exercise 4. □

5.10 Lemma. *If $\{\alpha\} \in H^*(X; R)$, $\{\beta\} \in H^*(Y; R)$, and $\{\gamma\} \in H^*(W; R)$, then*

$$(\{\alpha\} \times_1 \{\beta\}) \times_1 \{\gamma\} = \{\alpha\} \times_1 (\{\beta\} \times_1 \{\gamma\}).$$

EXERCISE 5. Prove Lemma 5.10. □

Observe that if we take $Y = \text{point}$, then $H^*(Y; R) = H^0(Y; R) \approx R$ and the external product

$$H^*(X; R) \otimes H^*(Y; R) \rightarrow H^*(X \times Y; R)$$

has the form

$$H^*(X; R) \otimes R \rightarrow H^*(X; R).$$

This gives $H^*(X; R)$ the structure of a graded R -module. Moreover, it follows from Lemma 5.9 that any map $f: X' \rightarrow X$ induces an R -module homomorphism

$$f^*: H^*(X; R) \rightarrow H^*(X'; R).$$

For any space X let $d: X \rightarrow X \times X$ be the diagonal mapping given by $d(x) = (x, x)$. Then the composition

$$H^p(X; R) \otimes H^q(X; R) \rightarrow H^{p+q}(X \times X; R) \xrightarrow{d^*} H^{p+q}(X; R)$$

sending $\{\alpha\} \otimes \{\beta\}$ into $d^*(\{\alpha\} \times_1 \{\beta\})$ defines a multiplication in the R -module $H^*(X; R)$. This is called the *cup product* and is usually written $\{\alpha\} \cup \{\beta\}$ or just $\{\alpha\} \cdot \{\beta\}$.

By applying the previous lemmas we may conclude the following important result.

5.11 Theorem. *For R a commutative associative ring with unit, X a topological space, $H^*(X; R)$ is a commutative associative graded R -algebra with unit. Any continuous function $f: X' \rightarrow X$ induces an R -algebra homomorphism*

$$f^*: H^*(X; R) \rightarrow H^*(X'; R) \quad \text{of degree zero.} \quad \square$$

As a point of information, a graded R -algebra $M = \sum_k M^k$ is *commutative* if given any homogeneous elements $m_p \in M^p$ and $m_q \in M^q$, we have

$$m_p \cdot m_q = (-1)^{pq} m_q m_p \quad \text{in } M^{p+q}.$$

Note: It is important to observe that while all of the development of products so far has been in terms of single spaces for the sake of clarity, the same constructions may be duplicated using pairs of spaces and relative homology and cohomology groups. It is important to point out that in this context, the cartesian product of pairs is another pair given by

$$(X, A) \times (Y, B) = (X \times Y, X \times B \cup A \times Y).$$

EXERCISE 6. Is the connecting homomorphism in the long exact cohomology sequence for the pair (X, A) an R -module homomorphism? An R -algebra homomorphism?

The essential tool used in defining the cup product of two cohomology classes is the composition of chain maps

$$S_*(X) \xrightarrow{d_*} S_*(X \times X) \xrightarrow{\phi} S_*(X) \otimes S_*(X).$$

More generally, suppose that $\tau: S_*(X) \rightarrow S_*(X) \otimes S_*(X)$ is a chain map such that

- (i) $\tau(a) = a \otimes a$ for any singular 0-simplex a ;
- (ii) τ commutes appropriately with homomorphisms induced by maps of spaces.

Then by applying the acyclic model theorem, Theorem 5.3, we see that any such τ must be chain homotopic to $\phi \circ d_*$. This implies that the cup product on cohomology classes is independent of the choice of τ as long as the stated conditions are satisfied. A chain map τ with these properties is usually called a *diagonal approximation*. For use in later definitions and examples it will be helpful to have a specific example for τ . The following is the *Alexander-Whitney* diagonal approximation.

Given a singular n -simplex $\phi: \sigma^n \rightarrow X$ in a space X , define the *front i -face* ϕ_i , $0 \leq i \leq n$, to be the singular i -simplex

$$\phi_i(t_0, \dots, t_i) = \phi(t_0, \dots, t_i, 0, \dots, 0).$$

Similarly let the *back j -face* ϕ_j , $0 \leq j \leq n$, be the singular j -simplex

$$\phi_j(t_0, \dots, t_j) = \phi(0, \dots, 0, t_0, \dots, t_j).$$

Then define

$$\tau(\phi) = \sum_{i+j=n} \phi_i \otimes \phi_j$$

for ϕ a singular n -simplex in X .

For example, if $\phi: \sigma^2 \rightarrow \sigma^2$ is the identity, then $\tau(\phi) = 0 \otimes \phi + (0, 1) \otimes (1, 2) + \phi \otimes 2$ where 0 and 2 are the obvious 0-simplices and $(0, 1)$ and $(1, 2)$ are 1-simplices (see Figure 5.1).

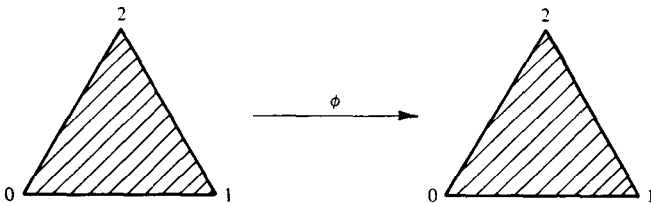

Figure 5.1

It is evident that Properties (i) and (ii) above are satisfied by τ . The only mild complication is left as the following exercise.

EXERCISE 7. Show that the Alexander-Whitney diagonal approximation τ is a chain map.

Using this specific model for τ , let us see exactly what the cup product looks like. Let $\alpha \in S^p(X; \mathbb{R})$ and $\beta \in S^q(X; \mathbb{R})$ and ϕ be a singular $(p + q)$ -simplex in X . Then

$$\langle \alpha \cup \beta, \phi \rangle$$

is the image of the composition

$$\phi \xrightarrow{\tau} \sum_i \phi \otimes \phi_j \xrightarrow{\alpha \otimes \beta} \alpha(\phi_i) \otimes \beta(\phi_j) \xrightarrow{\mu} \alpha(\phi_i) \cdot \beta(\phi_j).$$

Thus, $\langle \alpha \cup \beta, \phi \rangle = \langle \alpha, \phi_i \rangle \cdot \langle \beta, \phi_j \rangle$.

EXAMPLE. We want to compute the cohomology ring of the two-dimensional torus $T^2 = S^1 \times S^1$. Recall that $H_1(T^2; \mathbb{Z}) \approx \mathbb{Z} \oplus \mathbb{Z}$, and the generators may be represented by $\bar{\alpha}$ and $\bar{\beta}$ in Figure 5.2b. For $H_2(T^2; \mathbb{Z}) \approx \mathbb{Z}$ we may use as generator the 2-chain $\phi - \psi$, where (Figure 5.2c)

$$\phi(0) = a_0, \quad \phi(1) = a_1, \quad \phi(2) = a_2$$

and

$$\psi(0) = a_0, \quad \psi(1) = a_3, \quad \psi(2) = a_2$$

(see Figure 5.2a).

Using the universal coefficient theorem, Theorem 3.14, we see that $H^1(T^2; \mathbb{Z}) \approx \text{Hom}(H_1(T^2; \mathbb{Z}), \mathbb{Z})$ and we choose as generators α, β , where

$$\alpha(\bar{\alpha}) = 1, \quad \alpha(\bar{\beta}) = 0,$$

$$\beta(\bar{\alpha}) = 0, \quad \beta(\bar{\beta}) = 1.$$

Now

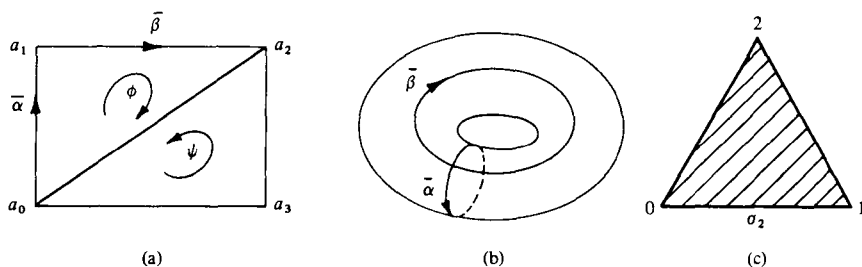

Figure 5.2

$$\begin{aligned}
\langle \alpha \cup \beta, \phi - \psi \rangle &= \langle \alpha, {}_1\phi \rangle \cdot \langle \beta, \phi_1 \rangle - \langle \alpha, {}_1\psi \rangle \cdot \langle \beta, \psi_1 \rangle \\
&= \langle \alpha, \bar{\alpha} \rangle \cdot \langle \beta, \bar{\beta} \rangle - \langle \alpha, \bar{\beta} \rangle \cdot \langle \beta, \bar{\alpha} \rangle \\
&= 1 - 0 \\
&= 1.
\end{aligned}$$

On the other hand

$$\begin{aligned}
\langle \alpha \cup \alpha, \phi - \psi \rangle &= \langle \alpha, \bar{\alpha} \rangle \cdot \langle \alpha, \bar{\beta} \rangle - \langle \alpha, \bar{\beta} \rangle \cdot \langle \alpha, \bar{\alpha} \rangle \\
&= 0.
\end{aligned}$$

Similarly $\langle \beta \cup \beta, \phi - \psi \rangle = 0$. Since $H^2(T^2; \mathbf{Z}) \approx \text{Hom}(H_2(T^2; \mathbf{Z}), \mathbf{Z}) \approx \mathbf{Z}$, we now have computed the cohomology ring $H^*(T^2; \mathbf{Z})$. Thus, $H^*(T^2; \mathbf{Z})$ is the graded algebra over \mathbf{Z} generated by elements α and β of degree 1, subject to the relations

$$\alpha^2 = 0, \quad \beta^2 = 0, \quad \alpha\beta = -\beta\alpha.$$

Note: This has the form of an exterior algebra on two generators. How about the cohomology ring of the n -torus $T^n = S^1 \times \cdots \times S^1$?

Suppose that $f: S^{2n-1} \rightarrow S^n$ is a map, $n \geq 2$. There is a procedure for associating with such a map an integer $H(f)$, the *Hopf invariant* of f . This may be defined using the cup product in the following way: Let $\{\alpha\}$ and $\{\beta\}$ be generators of the cohomology groups $H^{2n-1}(S^{2n-1}; \mathbf{Z})$ and $H^n(S^n; \mathbf{Z})$, respectively, represented by the cocycles α and β . Since $\{\beta\} \cup \{\beta\} = 0$, the cocycle $\beta \cup \beta$ must be a coboundary. That is, there exists a cochain $\gamma \in S^{2n-1}(S^n; \mathbf{Z})$ with

$$\delta\gamma = \beta \cup \beta.$$

Since $H^n(S^{2n-1}; \mathbf{Z}) = 0$, the cocycle $f^*(\beta) \in S^n(S^{2n-1}; \mathbf{Z})$ must be a coboundary, and there exists a cochain ε in $S^{n-1}(S^{2n-1}; \mathbf{Z})$ such that $\delta\varepsilon = f^*(\beta)$.

Now $\varepsilon \cup f^*(\beta)$ and $f^*(\gamma)$ are cochains in $S^{2n-1}(S^{2n-1}; \mathbf{Z})$. Moreover

$$\begin{aligned}
\delta(\varepsilon \cup f^*(\beta) - f^*(\gamma)) &= \delta(\varepsilon \cup \delta\varepsilon) - f^*(\beta \cup \beta) \\
&= \delta\varepsilon \cup \delta\varepsilon - f^*(\beta) \cup f^*(\beta) \\
&= 0.
\end{aligned}$$

So we define $H(f)$ to be the integer which when multiplied times $\{\alpha\}$ gives the cohomology class of $\varepsilon \cup f^*(\beta) - f^*(\gamma)$. That is

$$\{\varepsilon \cup f^*(\beta) - f^*(\gamma)\} = H(f) \cdot \{\alpha\}.$$

EXERCISE 8. (a) Let $f: S^{2n-1} \rightarrow S^n$ be a map of Hopf invariant k . If $\bar{g}: S^{2n-1} \rightarrow S^{2n-1}$ and $g: S^n \rightarrow S^n$ are maps of degree p , determine $H(gf)$ and $H(f\bar{g})$.

(b) If

$$\begin{array}{ccc}
 S^{2n-1} & \xrightarrow{\bar{h}} & S^{2n-1} \\
 \downarrow f & & \downarrow f \\
 S^n & \xrightarrow{h} & S^n
 \end{array}$$

is a commutative diagram where f has Hopf invariant k , how are the degrees of h and \bar{h} related?

Let us give an alternate definition for $H(f)$. Recall that S^n and S^{2n-1} may be given the structure of finite CW complexes, each having only two cells. Given a map $f: S^{2n-1} \rightarrow S^n$, we denote by S_f^n the space obtained by attaching a $2n$ -cell to S^n via f (see Chapter 2). Then S_f^n is a finite CW complex with three cells, of dimension 0, n , and $2n$. Applying the technique of Theorem 2.21 we see that since $n > 1$, the cohomology of S_f^n is given by

$$H^i(S_f^n) \approx \begin{cases} \mathbb{Z} & \text{for } i = 0, n, 2n \\ 0 & \text{otherwise.} \end{cases}$$

Denoting by $b \in H^n(S_f^n; \mathbb{Z})$ and $a \in H^{2n}(S_f^n; \mathbb{Z})$ a chosen pair of generators, we define $H(f)$ to be that integer for which $b^2 = H(f) \cdot a$ in $H^{2n}(S_f^n; \mathbb{Z})$.

EXERCISE 9. Show that the two definitions of $H(f)$ are equivalent.

In order to show that $H(f)$ is an invariant of the homotopy class of f , we need the following result due to J. H. C. Whitehead.

5.12 Proposition. *If $f_0, f_1: S^p \rightarrow X$ are homotopic maps into a space X , then the identity map of X extends to a homotopy equivalence*

$$h: X_{f_0} \rightarrow X_{f_1}.$$

Proof. Let $\{f_t\}$ be a homotopy between f_0 and f_1 and denote an element of D^{p+1} by θu , where $u \in S^p$ and $0 \leq \theta \leq 1$.

Given a radius in the attached disk in X_{f_0} (Figure 5.3a), the inner half should be mapped onto the corresponding radius in X_{f_1} . Then the outer half is used to trace out the path of the homotopy from $f_1(u)$ to $f_0(u)$ (Figure 5.3b). Specifically then define the map h by

$$\begin{aligned}
 h(x) &= x && \text{for } x \in X; \\
 h(\theta u) &= 2\theta u && \text{for } u \in S^p, \quad 0 \leq \theta \leq \frac{1}{2}; \\
 h(\theta u) &= f_{2-2\theta}(u) && \text{for } u \in S^p, \quad \frac{1}{2} \leq \theta \leq 1.
 \end{aligned}$$

Defining a similar map $h': X_{f_1} \rightarrow X_{f_0}$, it is easily seen that the compositions $h \circ h'$ and $h' \circ h$ are homotopic to the respective identities. □

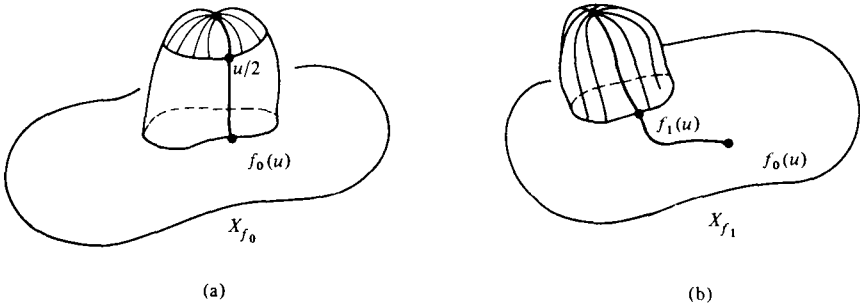

Figure 5.3

5.13 Proposition. *If $f_0, f_1: S^{2n-1} \rightarrow S^n$ are homotopic maps, then $H(f_0) = H(f_1)$.*

Proof. Let $h: S_{f_0}^n \rightarrow S_{f_1}^n$ be the homotopy equivalence given in Proposition 5.12. If $i_0: (D^{2n}, S^{2n-1}) \rightarrow (S_{f_0}^n, S^n)$ and $i_1: (D^{2n}, S^{2n-1}) \rightarrow (S_{f_1}^n, S^n)$, denote the relative homeomorphisms corresponding to f_0 and f_1 , the diagram

$$\begin{array}{ccc}
 (D^{2n}, S^{2n-1}) & \xrightarrow{i_0} & (S_{f_0}^n, S^n) \\
 & \searrow i_1 & \swarrow h \\
 & & (S_{f_1}^n, S^n)
 \end{array}$$

is homotopy commutative. This homotopy is easily defined by setting $g_t(\theta u) = h \circ i_0((1 - \frac{1}{2}t)\theta u)$.

This implies that the diagram of cohomology groups

$$\begin{array}{ccc}
 H^{2n}(S_{f_1}^n, S^n) & \xrightarrow{h^*} & H^{2n}(S_{f_0}^n, S^n) \\
 & \searrow i_1^* & \swarrow i_0^* \\
 & & H^{2n}(D^{2n}, S^{2n-1})
 \end{array}$$

is commutative. Thus, a choice of an orientation for D^{2n} dictates compatible choices of generators

$$\bar{a}_1 \in H^{2n}(S_{f_1}^n, S^n) \quad \text{and} \quad \bar{a}_0 \in H^{2n}(S_{f_0}^n, S^n)$$

and corresponding choices of generators

$$a_1 \in H^{2n}(S_{f_1}^n) \quad \text{and} \quad a_0 \in H^{2n}(S_{f_0}^n)$$

such that $h^*(a_1) = a_0$.

Furthermore, if $b_1 \in H^n(S_{f_1}^n)$ and $b_0 \in H^n(S_{f_0}^n)$ are generators corresponding

to a chosen orientation of D^n , then since h is the identity on S^n , it follows that $h^*(b_1) = b_0$.

Therefore

$$\begin{aligned} H(f_0) \cdot a_0 &= b_0^2 = (h^*(b_1))^2 \\ &= h^*(b_1^2) \\ &= h^*(H(f_1) \cdot a_1) \\ &= H(f_1) \cdot h^*(a_1) \\ &= H(f_1) \cdot a_0, \end{aligned}$$

and

$$H(f_0) = H(f_1). \quad \square$$

Note: If n is odd, the commutativity of the cup product implies that $b^2 = -b^2$, so that $H(f) = 0$. Thus, the Hopf invariant can only be nonzero for maps $f: S^{4n-1} \rightarrow S^{2n}$.

5.14 Proposition. *For any $n > 0$ there exist maps from S^{4n-1} to S^{2n} of arbitrary even Hopf invariant.*

Proof. As a corollary of Exercise 8, it is sufficient to show that there exists a map with Hopf invariant ± 2 .

Recall that $S^{2n} \times S^{2n}$ may be given the structure of a finite CW complex having one 0-cell, two $2n$ -cells, and one $4n$ -cell (see Proposition 2.6). Furthermore, there is a map

$$f: S^{4n-1} \rightarrow S^{2n} \vee S^{2n}$$

where $S^{2n} \vee S^{2n}$ is the $2n$ -skeleton of $S^{2n} \times S^{2n}$, such that $S^{2n} \times S^{2n}$ is the space obtained by attaching a $4n$ -cell to $S^{2n} \vee S^{2n}$ via f .

Define a map

$$g: S^{2n} \vee S^{2n} \rightarrow S^{2n}$$

by $g(x, p) = x$, $g(p, y) = y$, where $S^{2n} \vee S^{2n}$ is identified with

$$(S^{2n} \times p) \cup (p \times S^{2n}) \subseteq S^{2n} \times S^{2n}.$$

From the commutative diagram

$$\begin{array}{ccc} S^{4n-1} & \xrightarrow{f} & S^{2n} \vee S^{2n} \\ & \searrow gf & \swarrow g \\ & & S^{2n} \end{array}$$

we see that g induces a map

$$\tilde{g}: S^{2n} \times S^{2n} = (S^{2n} \vee S^{2n})_f \rightarrow S_{gf}^{2n}.$$

Using this map \tilde{g} we want to prove that the Hopf invariant of gf is ± 2 .

Let $e \in H^0(p)$, $1 \in H^0(S^{2n})$, and $c \in H^{2n}(S^{2n})$ be generators of these infinite cyclic groups. Then $H^{4n}(S^{2n} \times S^{2n})$ is the infinite cyclic group generated by $c \times c$ and $H^{2n}(S^{2n} \times S^{2n})$ is the free abelian group with basis consisting of $1 \times c$ and $c \times 1$. As before let $a \in H^{4n}(S_{gf}^{2n})$ and $b \in H^{2n}(S_{gf}^{2n})$ be generators of these infinite cyclic groups.

First, we must compute $\tilde{g}^*(b) \in H^{2n}(S^{2n} \times S^{2n})$. If $j: p \rightarrow S^{2n}$ is the inclusion, then both rectangles in the following diagram commute:

$$\begin{array}{ccccc} H^{2n}(S_{gf}^{2n}) & \xrightarrow{\tilde{g}^*} & H^{2n}(S^{2n} \times S^{2n}) & \xleftarrow{\times} & H^{2n}(S^{2n}) \otimes H^0(S^{2n}) \\ \cong \downarrow i^* & & \downarrow (\text{id} \times j)^* & & \cong \downarrow (\text{id})^* \otimes j^* \\ H^{2n}(S^{2n}) & \xrightarrow{=} & H^{2n}(S^{2n} \times p) & \xleftarrow[\cong]{\times} & H^{2n}(S^{2n}) \otimes H^0(p) \end{array}$$

Thus

$$i^*(b) = \pm c \times e = \pm(\text{id})^*(c) \times j^*(1)$$

or

$$(\text{id} \times j)^* \tilde{g}^*(b) = \pm(\text{id} \times j)^*(c \times 1).$$

This means that the element

$$\tilde{g}^*(b) \pm c \times 1$$

is in the kernel of $(\text{id} \times j)^*$ for some choice of sign. Now the kernel of $(\text{id} \times j)^*$ in $H^{2n}(S^{2n} \times S^{2n})$ is the infinite cyclic subgroup generated by $1 \times c$, so

$$\tilde{g}^*(b) \pm c \times 1 = m(1 \times c)$$

for some integer m .

By the same argument, $\tilde{g}^*(b) \pm 1 \times c = k(c \times 1)$ for some integer k . These two properties together imply that with a proper choice of sign, we have

$$\tilde{g}^*(b) = \pm c \times 1 \pm 1 \times c.$$

It can be easily checked that

$$\begin{aligned} (\pm c \times 1 \pm 1 \times c)^2 &= (c \times 1)^2 \pm 2(c \times 1) \cdot (1 \times c) + (1 \times c)^2 \\ &= c^2 \times 1 \pm 2c \times c + 1 \times c^2 \\ &= \pm 2c \times c, \end{aligned}$$

since $c^2 = 0$.

Finally, since

$$\tilde{g}^*: H^{4n}(S_{gf}^{2n}) \rightarrow H^{4n}(S^{2n} \times S^{2n})$$

is an isomorphism,

$$\begin{aligned}
 b^2 &= \tilde{g}^{*-1}(\tilde{g}^*(b^2)) = \tilde{g}^{*-1}((c \pm 1 \pm 1 \times c)^2) \\
 &= \tilde{g}^{*-1}(\pm 2c \times c) \\
 &= \pm 2a.
 \end{aligned}$$

This proves that $H(gf) = \pm 2$. □

There remains the question of the existence of maps having odd Hopf invariant. Using the results of the next chapter we will be able to show that the Hopf maps $S^3 \rightarrow S^2$ and $S^7 \rightarrow S^4$ each has Hopf invariant one. By using the Cayley numbers, one can define an analogous map $S^{15} \rightarrow S^8$ of Hopf invariant one. Results of Adem [1952] on certain cohomology operations imply that there can exist maps $f: S^{4n-1} \rightarrow S^{2n}$ of odd Hopf invariant only when n is a power of 2. Finally, there is a deep theorem due to Adams [1960], that for $n \neq 1, 2,$ or 4 there is no map $f: S^{4n-1} \rightarrow S^{2n}$ of odd Hopf invariant. An important consequence of this theorem is that the only values of n for which \mathbb{R}^n carries the structure of a real division algebra are: $n = 1$ (real numbers), $n = 2$ (complex numbers), and $n = 4$ (quaternions). [See Eilenberg and Steenrod, 1952, p. 320].

As a reference for further information on the Hopf invariant we recommend Hu [1959]. We cite only briefly one further result: two maps from S^3 to S^2 are homotopic if and only if they have the same Hopf invariant.

As the final topic of this chapter we introduce a variant of the cup product which will be useful in the following chapter. Let X be a space and R be a commutative ring with unit. If $\alpha \in S^p(X; R)$ we may view α as a homomorphism of all $S_*(X)$ into R by setting it equal to zero on elements of dimension different from p .

The composition

$$S_*(X) \xrightarrow{\tau} S_*(X) \otimes S_*(X) \xrightarrow{\alpha \otimes \text{id}} R \otimes S_*(X)$$

when tensored throughout with R yields

$$R \otimes S_*(X) \xrightarrow{\text{id} \otimes \tau} R \otimes S_*(X) \otimes S_*(X) \xrightarrow{\text{id} \otimes \alpha \otimes \text{id}} R \otimes R \otimes S_*(X) \xrightarrow{\mu \otimes \text{id}} R \otimes S_*(X).$$

If $c \in S_n(X; R) = R \otimes S_n(X)$, we define the *cap product* of α and c , $\alpha \cap c$, to be the image of c under this composition. Note that

$$\alpha \cap c \in S_{n-p}(X; R).$$

For example, suppose τ is the Alexander–Whitney diagonal and ϕ is a singular n -simplex. Then the above composition has

$$1 \otimes \phi \rightarrow 1 \otimes \left\{ \sum_{i+j=n} i\phi \otimes \phi_j \right\} \rightarrow 1 \otimes \alpha(\phi) \otimes \phi_{n-p} \rightarrow \alpha(\phi) \otimes \phi_{n-p}.$$

If we interpret $R \otimes S_*(X)$ as the free R -module generated by the singular simplices of X , then

$$\alpha \cap \phi = \alpha(\phi) \cdot \phi_{n-p}.$$

It is evident that this is closely connected to the cup product. To make this relationship specific, let $\alpha \in S^p(X; R)$, $\beta \in S^q(X; R)$ and $\phi \in S_{p+q}(X; R)$, where ϕ is a singular simplex. Then

$$\langle \beta \cup \alpha, \phi \rangle = \beta(\phi) \cdot \alpha(\phi).$$

On the other hand

$$\langle \alpha, \beta \cap \phi \rangle = \langle \alpha, \beta(\phi) \cdot \phi_p \rangle = \beta(\phi) \cdot \alpha(\phi).$$

Since this is true for all ϕ , it follows that for any $c \in S_{p+q}(X; R)$,

$$(5.15) \quad \langle \beta \cup \alpha, c \rangle = \langle \alpha, \beta \cap c \rangle.$$

Finally, we must determine the action of ∂ on the chain $\alpha \cap c$. To do this we evaluate an arbitrary cochain γ on $\partial(\alpha \cap c)$,

$$\langle \gamma, \partial(\alpha \cap c) \rangle = \langle \delta\gamma, \alpha \cap c \rangle = \langle \alpha \cup \delta\gamma, c \rangle.$$

Suppose that $\alpha \in S^q(X; R)$, $c \in S_n(X; R)$ so that $\alpha \cap c \in S_{n-q}(X; R)$. Recall that

$$\delta(\alpha \cup \gamma) = \delta\alpha \cup \gamma + (-1)^q \alpha \cup \delta\gamma$$

or

$$\alpha \cup \delta\gamma = (-1)^q (\delta(\alpha \cup \gamma) - (\delta\alpha) \cup \gamma).$$

So by substituting into the previous equation we have

$$\begin{aligned} \langle \gamma, \partial(\alpha \cap c) \rangle &= (-1)^q \langle \delta(\alpha \cup \gamma) - \delta\alpha \cup \gamma, c \rangle \\ &= (-1)^q [\langle \gamma, \alpha \cap \delta c \rangle - \langle \gamma, \delta\alpha \cap c \rangle] \\ &= \langle \gamma, (-1)^q (\alpha \cap \partial c - \delta\alpha \cap c) \rangle. \end{aligned}$$

Since this is true for all cochains γ , it follows that

$$(-1)^q \partial(\alpha \cap c) = (\alpha \cap \partial c) - (\delta\alpha \cap c).$$

From this derivation formula we conclude that the cap product on chain groups induces a well-defined product on homology groups which takes the form

$$H^q(X; R) \otimes H_n(X; R) \rightarrow H_{n-q}(X; R)$$

and sends $\{\alpha\} \otimes \{c\}$ into $\{\alpha \cap c\}$.

EXERCISE 10. Formulate and prove a statement showing that the cap product is natural with respect to homomorphisms induced by mappings of spaces.

EXERCISE 11. A graded group $\{G_q\}$ is said to be of *finite type* if for each q , G_q is finitely generated. Prove the following theorem.

5.16 Theorem (Cohomology Künneth formula). *Let G and G' be abelian groups with $\text{Tor}(G, G') = 0$. If $H_*(X; Z)$ and $H_*(Y; Z)$ are of finite type, then*

there is a split exact sequence

$$0 \rightarrow \sum_{p+q=n} H^p(X; G) \otimes H^q(Y; G') \xrightarrow{\times} H^n(X \times Y; G \otimes G') \\ \rightarrow \sum_{p+q=n+1} \text{Tor}(H^p(X; G), H^q(Y; G')) \rightarrow 0. \quad \square$$

EXERCISE 12. Let X and Y be spaces and R be a commutative ring. If $u_1 \in H^p(X; R)$, $u_2 \in H^q(X; R)$, $v_1 \in H^r(Y; R)$, and $v_2 \in H^s(Y; R)$, then in $H^{p+q+r+s}(X \times Y; R)$ we have

$$(u_1 \times v_1) \cup (u_2 \times v_2) = (-1)^{qr}(u_1 \cup u_2) \times (v_1 \cup v_2).$$

EXERCISE 13. If $u \in H^p(X; R)$, $v \in H^q(Y; R)$, $p_1: X \times Y \rightarrow X$, and $p_2: X \times Y \rightarrow Y$ are the projection maps, then

$$u \times v = p_1^*(u) \cup p_2^*(v).$$

EXERCISE 14. If $u_1 \in H^p(X; R)$, $u_2 \in H^q(Y; R)$, $z_1 \in H_m(X; R)$, and $z_2 \in H_n(Y; R)$, then in $H_{m+n-p-q}(X \times Y; R)$ we have

$$(u_1 \times u_2) \cap (z_1 \times z_2) = (-1)^{q(m-p)}(u_1 \cap z_1) \times (u_2 \cap z_2).$$

EXERCISE 15. Show that the cap product may be extended to relative homology and cohomology groups of a pair to give products of the form

$$H^k(X, A) \otimes H_n(X, A) \rightarrow H_{n-k}(X)$$

and

$$H^k(X) \otimes H_n(X, A) \rightarrow H_{n-k}(X, A).$$

CHAPTER 6

Manifolds and Poincaré Duality

This chapter deals with some of the basic homological properties of topological manifolds. Since the main result is the Poincaré duality theorem, we begin with a simple example to establish an intuitive feeling for this classical result. This is followed by material on topological manifolds and a detailed proof of the theorem. The approach used follows the excellent treatment of Samelson [1965, pp. 323–336] and proceeds by way of the Thom isomorphism theorem. Several applications of the theorem follow, including the determination of the cohomology rings of projective spaces and results on the index of topological manifolds and cobordism.

Before proceeding with the general approach, let us see how the theorem may be motivated from an example. Briefly, the Poincaré duality theorem will say that if M is a compact oriented n -manifold without boundary, the i th Betti number of M is the same as the $(n - i)$ th Betti number for $0 \leq i \leq n$. In the following example we will indicate how such a correspondence arises.

Suppose we are given a portion of a triangulated surface K as shown in Figure 6.1. By taking the first barycentric subdivision (see Appendix I) we arrive at a new triangulation K' , as shown in Figure 6.2. If v is a vertex in this new triangulation, define the *star* of v in K' to be the union of all open cells in K' that contain v in their closure. Thus, $\text{star}(A; K')$ is the open 2-cell shown in Figure 6.3, whereas $\text{star}(v_0; K')$ is the open 2-cell shown in Figure 6.4.

Given a simplex σ in K , we define its *dual cell* σ^* in K' by

$$\sigma^* = \bigcap_v \overline{\text{star}(v; K')},$$

where v ranges over the vertices of σ . For example, the dual of the vertex A is $\overline{\text{star}(A; K')}$, the closure of Figure 6.3, while the dual of the 2-simplex ABC is the vertex v_0 . Similarly the dual of the 1-simplex AB is the 1-cell joining v_0

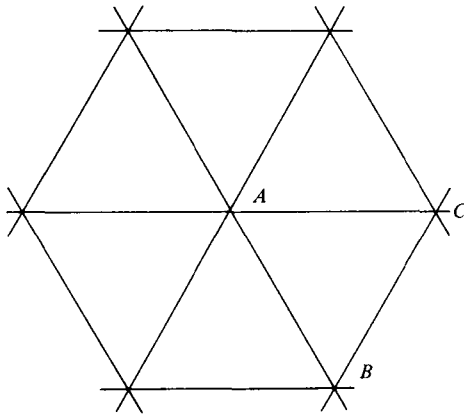

Figure 6.1

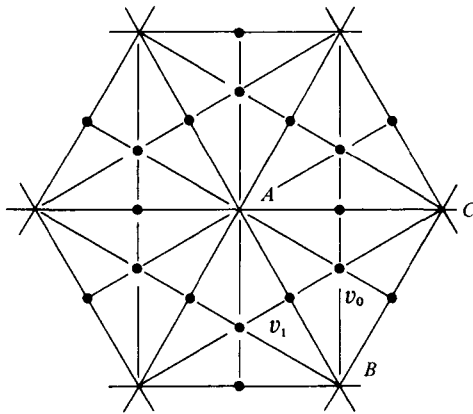

Figure 6.2

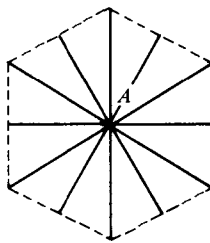

Figure 6.3

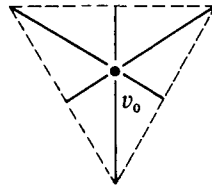

Figure 6.4

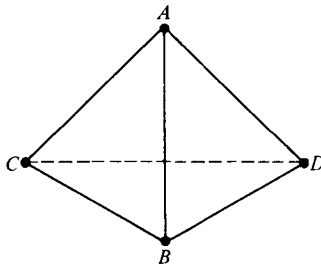

Figure 6.5

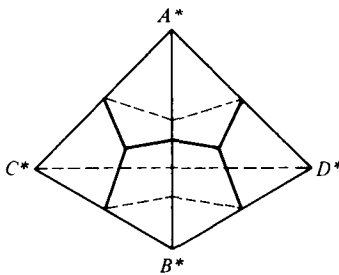

Figure 6.6

and v_1 . Note that while the dual of a simplex need not be a simplex, it is a cell in the complementary dimension.

As a specific example we take the boundary of a 3-simplex, a triangulated surface homeomorphic to S^2 (Figure 6.5). This surface may be viewed as a finite CW complex having four 0-cells, six 1-cells, and four 2-cells. By taking the dual cells of each of these simplices we get a corresponding CW decomposition for the same space as shown in Figure 6.6. Here we have four 2-cells (A^* , B^* , C^* , D^*), six 1-cells (AB^* , \dots , CD^*), and four 0-cells (ABC^* , \dots , BCD^*).

To compute the Betti numbers of these complexes we use the cellular chain complex of Theorem 2.21. Recall that if Y is a finite CW complex and

$$C_{i+1}(Y) \xrightarrow{\hat{\tau}_{i+1}} C_i(Y) \xrightarrow{\hat{\tau}_i} C_{i-1}(Y)$$

is a portion of the chain complex, then the i th Betti number

$$\beta_i(Y) = \alpha_i(Y) - \gamma_{i+1}(Y) - \gamma_i(Y),$$

where $\alpha_i(Y)$ is the number of i -cells in Y and $\gamma_j(Y)$ is the rank of the image of ∂_j .

Denoting by X and X^* the two structures above we may make the following comparisons:

$\alpha_0(X) = 4$	$\alpha_2(X^*) = 4$
given by A, B, C, D	given by A^*, B^*, C^*, D^*
$\alpha_1(X) = 6$	$\alpha_1(X^*) = 6$
given by AB, \dots, CD	given by AB^*, \dots, CD^*
$\alpha_2(X) = 4$	$\alpha_0(X^*) = 4$
given by ABC, \dots, BCD	given by ABC^*, \dots, BCD^*
$\gamma_0(X) = 0$	$\gamma_3(X^*) = 0$
$\gamma_1(X) = 3$, basis	$\gamma_2(X^*) = 3$, basis
given by $A - B, A - C, A - D$	given by $\partial(A^* - B^*),$ $\partial(A^* - C^*), \partial(A^* - D^*)$
$\gamma_2(X) = 3$, basis	$\gamma_1(X^*) = 3$, basis
given by $\partial(ABC - ABD),$ $\partial(ABC - ADC), \partial(ABC - BCD)$	given by $ABC^* - ABD^*,$ $ABC^* - ADC^*, ABC^* - BCD^*$
$\gamma_3(X) = 0.$	$\gamma_0(X^*) = 0.$

Putting this information together, it is evident that $\beta_0(X) = \beta_2(X^*) = 1$, $\beta_1(X) = \beta_1(X^*) = 0$, and $\beta_2(X) = \beta_0(X^*) = 1$. It may be helpful to keep this sort of geometric picture in mind as we develop the algebraic techniques necessary to establish the theorem in its general setting.

In \mathbb{R}^n define the half-space \mathbb{H}^n to be the set of all points (x_1, \dots, x_n) such that $x_n \geq 0$. A *topological n -manifold* is a Hausdorff space M having a countable basis of open sets, with the property that every point of M has a neighborhood homeomorphic to an open subset of \mathbb{H}^n . The *boundary* of M , denoted ∂M , is the set of all points x in M for which there exists a homeomorphism of some neighborhood of x onto an open set in \mathbb{H}^n taking x into $\{(x_1, \dots, x_n) \mid x_n = 0\} = \partial \mathbb{H}^n \subseteq \mathbb{H}^n$.

EXERCISE 1. Let h be a homeomorphism of an open subset U of \mathbb{H}^n onto an open subset of \mathbb{H}^n . If $x \in U \cap \partial \mathbb{H}^n$, then show $h(x) \in \partial \mathbb{H}^n$.

It follows immediately from this exercise that if $x \in \partial M$, then *all* homeomorphisms from open sets about x to open sets in \mathbb{H}^n must map x into

$\partial \mathbb{H}^n$. M is an n -manifold without boundary if $\partial M = \emptyset$, or, equivalently, if each $x \in M$ has a neighborhood homeomorphic to an open set in \mathbb{R}^n . A closed n -manifold is a compact n -manifold without boundary.

EXAMPLES. (1) Any open subset of \mathbb{H}^n is obviously an n -manifold.

(2) For each point $x \in S^n$, stereographic projection from $-x$ is a homeomorphism from $S^n - \{-x\}$ onto \mathbb{R}^n . This gives S^n the structure of a closed n -manifold.

(3) For each point $y \in \mathbb{R}P(n)$ pick a point $x \in S^n$ with $\pi(x) = y$, where

$$\pi: S^n \rightarrow \mathbb{R}P(n)$$

is the identification map. Let $i: (D^n - S^{n-1}) \rightarrow S^n$ be the inclusion of the open hemisphere centered at x . Then $\pi \circ i$ is a homeomorphism of an open subset of \mathbb{R}^n onto an open set about y . Therefore, $\mathbb{R}P(n)$ is a closed n -manifold.

(4) Let $GL(n)$ denote the set of all real $n \times n$ matrices having nonzero determinant. By ordering the entries we may view $GL(n)$ as a subspace of \mathbb{R}^{n^2} and give it the induced topology. Under this identification, the determinant function $\mathbb{R}^{n^2} \rightarrow \mathbb{R}$ is continuous and has $GL(n)$ as the inverse of the open set $\mathbb{R} - \{0\}$. Thus, $GL(n)$ is an open subset of \mathbb{R}^{n^2} and hence is an n^2 -manifold without boundary.

(5) The Möbius band, formed by identifying the two ends of a rectangle so that the indicated arrows coincide (Figure 6.7), is obviously a 2-manifold with boundary.

6.1 Lemma. *If U is an open subset of \mathbb{R}^n , then $H_i(U) = 0$ for $i \geq n$.*

Proof. Before proceeding with the proof, we point out a slight generalization of the chain complex in Theorem 2.21. If (X, A) is a finite CW pair, the groups

$$H_p(X^p \cup A, X^{p-1} \cup A)$$

form a chain complex whose homology is $H_*(X, A)$. Note that if every cell of X of dimension greater than p is contained in A , then $H_i(X, A) = 0$ for $i > p$.

Let $\{z\} \in H_i(U)$ be an homology class represented by an i -cycle z , $i \geq n$. The image of each singular simplex in U is a compact subset. Since z is a finite linear combination of singular i -simplices, the union of the associated images forms a compact subset $X \subseteq U$.

Define

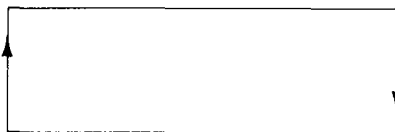

Figure 6.7

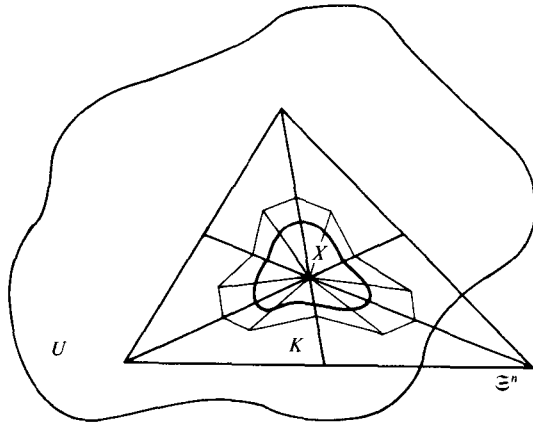

Figure 6.8

$$\varepsilon = \text{Inf}\{\|x - y\| \mid x \in X, y \in \mathbb{R}^n - U\}.$$

Note that $\varepsilon > 0$, since X is compact, $\mathbb{R}^n - U$ is closed, and $X \cap (\mathbb{R}^n - U) = \emptyset$. Since X is compact, there exists a large simplex \mathfrak{S}^n in \mathbb{R}^n such that X is contained in the interior of \mathfrak{S}^n .

From Appendix I we know that there exists an integer m with mesh $\text{Sd}^m \mathfrak{S}^n < \varepsilon$. Now consider $\text{Sd}^m \mathfrak{S}^n$ as a finite CW complex under the simplicial decomposition. Let K be the subcomplex of $\text{Sd}^m \mathfrak{S}^n$ consisting of all faces of simplices which intersect X (Figure 6.8). Note that by construction

$$X \subseteq K \subseteq U.$$

A portion of the exact homology sequence of the finite CW pair $(\text{Sd}^m \mathfrak{S}^n, K)$ has the form

$$\cdots \rightarrow H_{i+1}(\text{Sd}^m \mathfrak{S}^n, K) \rightarrow H_i(K) \rightarrow H_i(\text{Sd}^m \mathfrak{S}^n) \rightarrow \cdots.$$

By our previous comments, $H_{i+1}(\text{Sd}^m \mathfrak{S}^n, K) = 0$. Also $H_i(\text{Sd}^m \mathfrak{S}^n) = 0$ since the space is a simplex, hence, a convex subset of \mathbb{R}^n (see Theorem 1.8). Therefore, $H_i(K) = 0$.

Since z was a cycle in X , it is also a cycle in K . The fact that $H_i(K) = 0$ implies that z bounds an $(i + 1)$ -chain in K . But this $(i + 1)$ -chain also lies in U ; hence, z bounds a chain in U and $\{z\} = 0$. □

6.2 Lemma. *If M is an n -manifold without boundary, then $H_i(M) = 0$ for $i > n$.*

Proof. Let z be an i -cycle in M , $i > n$. Then as in Lemma 6.1 we associate with z the compact subset $X \subseteq M$, which is the union of the images of the singular simplices which make up z . There exists a finite collection U_1, \dots, U_m of open sets in M , each homeomorphic to an open set in \mathbb{R}^n , with $X \subseteq \bigcup U_j$. (Open

sets of this type will usually be called *coordinate neighborhoods* or *coordinate charts*.) We will show that $\{z\} = 0$ by proving that $H_i(\bigcup U_j) = 0$ so that z must bound in $\bigcup U_j$.

Proceeding by induction on the number of coordinate neighborhoods, it is true for $m = 1$ by Lemma 6.1. Suppose that

$$H_i\left(\bigcup_{j=1}^r U_j\right) = 0.$$

There is a Mayer–Vietoris sequence for the space $(\bigcup_{j=1}^r U_j) \cup U_{r+1}$, which has the form

$$\cdots \rightarrow H_i\left(\bigcup_{j=1}^r U_j\right) \oplus H_i(U_{r+1}) \rightarrow H_i\left(\bigcup_{j=1}^{r+1} U_j\right) \rightarrow H_{i-1}\left(\left(\bigcup_{j=1}^r U_j\right) \cap U_{r+1}\right) \rightarrow \cdots$$

The term on the right is zero by Lemma 6.1 since the space is an open subset of a coordinate chart; similarly $H_i(U_{r+1}) = 0$. It follows from the inductive hypothesis that $H_i(\bigcup_{j=1}^{r+1} U_j) = 0$. This completes the inductive step. \square

This result tells us that the nontrivial homology of such a manifold all occurs in dimensions less than or equal to the dimension of the manifold. When the manifold is connected but not compact, this result may be refined to show that the top-dimensional homology group (dimension of the manifold) must also be zero. To establish this, we need the following lemmas.

6.3 Lemma. *Let U be open in \mathbb{R}^n and $a \in H_n(\mathbb{R}^n, U)$. If for every $p \in \mathbb{R}^n - U$, the homomorphism induced by inclusion*

$$j_{p*}: H_n(\mathbb{R}^n, U) \rightarrow H_n(\mathbb{R}^n, \mathbb{R}^n - p)$$

has $j_{p*}(a) = 0$, then $a = 0$.

Proof. The connecting homomorphism for the exact sequence of the pair (\mathbb{R}^n, U) gives an isomorphism

$$\Delta: H_n(\mathbb{R}^n, U) \xrightarrow{\cong} H_{n-1}(U).$$

We will prove that $a = 0$ by establishing that $\Delta(a) = 0$ in $H_{n-1}(U)$.

So let $b = \Delta(a)$. Once again, since the “image” of a cycle representing b is a compact subset of U , there exists an open set V with \bar{V} compact $\subseteq U$ and an element b' in $H_{n-1}(V)$ with $i_*(b') = b$, $i: V \rightarrow U$ the inclusion.

Let Q be an open cube containing V and define $K = Q - Q \cap U$ (Figure 6.9). For each point p in \bar{K} there exists a closed cube P containing p such that $P \cap V = \emptyset$. From the diagram

$$\begin{array}{ccccc} H_{n-1}(V) & \xrightarrow{i_*} & H_{n-1}(U) & \xleftarrow[\cong]{\Delta} & H_n(\mathbb{R}^n, U) \\ \downarrow & & \downarrow & & \downarrow j_{p*} \\ H_{n-1}(\mathbb{R}^n - p) & \xrightarrow[\cong]{} & H_{n-1}(\mathbb{R}^n - p) & \xleftarrow[\cong]{\Delta} & H_n(\mathbb{R}^n, \mathbb{R}^n - p) \end{array}$$

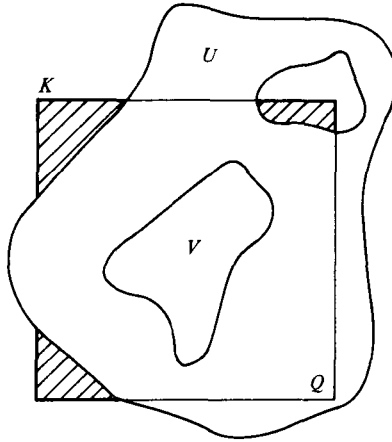

Figure 6.9

in which the rectangles commute, it is evident that the image of b' under the homomorphism

$$H_{n-1}(V) \rightarrow H_{n-1}(\mathbb{R}^n - p)$$

is zero. A finite number of such closed cubes cover \bar{K} , say P_1, \dots, P_m .

Now suppose that the image of b' under the homomorphism

$$H_{n-1}(V) \rightarrow H_{n-1}(Q - (P_1 \cup \dots \cup P_k))$$

is zero (this is certainly true when $k = 0$, since Q is contractible).

Denoting $Q_k = Q - (P_1 \cup \dots \cup P_k)$, consider the Mayer–Vietoris sequence relating Q_k and $\mathbb{R}^n - P_{k+1}$:

$$\begin{aligned} \cdots &\rightarrow H_n(Q_k \cup (\mathbb{R}^n - P_{k+1})) \\ &\rightarrow H_{n-1}(Q_{k+1}) \xrightarrow{\text{mono}} H_{n-1}(Q_k) \oplus H_{n-1}(\mathbb{R}^n - P_{k+1}) \rightarrow \cdots \end{aligned}$$

The first group is zero by Lemma 6.1. The images of b' in the two direct summands are both zero; hence, the image of b' in $H_{n-1}(Q_{k+1})$ is zero. This completes the inductive step and we conclude that the image of b' under the homomorphism

$$H_{n-1}(V) \rightarrow H_{n-1}(Q - (P_1 \cup \dots \cup P_m)) \xrightarrow{(\text{incl})_*} H_{n-1}(Q \cap U)$$

is zero. Since the inclusion of V in U factors through $Q \cap U$, it follows that the image of b' in $H_{n-1}(U)$, that is, b , is zero. Hence, $a = 0$. \square

6.4 Lemma. *If x and y are points in the interior of a connected n -manifold M , then there is a homeomorphism $h: M \rightarrow M$, homotopic to the identity, having $h(x) = y$.*

Proof. Note that since M is locally homeomorphic to \mathbb{H}^n , M is locally pathwise connected. That is, each point of M is contained in a pathwise connected

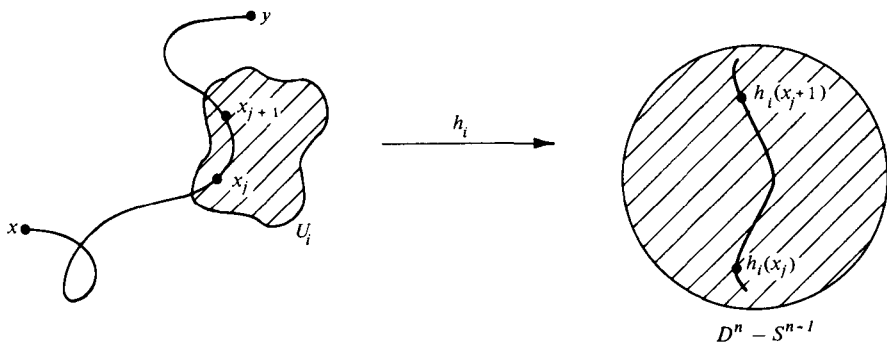

Figure 6.10

open set. This implies that the path components of M are both open and closed. Since M is connected, there can be only one path component, so M must be pathwise connected.

Now if M is connected, so is $M - \partial M =$ the interior of M (see the following exercise). So let $p: [0, 1] \rightarrow M - \partial M$ be a path from x to y . This compact subset of $M - \partial M$ may be covered by a finite number of open sets, each homeomorphic to the open unit disk in \mathbb{R}^n . Denote these disks by U_1, \dots, U_m and the corresponding homeomorphisms by h_1, \dots, h_m .

Let $x = x_0, x_1, \dots, x_k = y$ be a collection of points on the path with the property that for each j , the segment from x_j to x_{j+1} is contained in some U_i (Figure 6.10). The desired homeomorphism may now be constructed inductively. It is sufficient then to show that for $0 \leq j < k$ there is a homeomorphism $h: M \rightarrow M$, homotopic to the identity, with $h(x_j) = x_{j+1}$.

So suppose x_j and x_{j+1} are in U_i . Define a homeomorphism

$$g: D^n - S^{n-1} \rightarrow \mathbb{R}^n$$

by

$$g(z) = \frac{z}{1 - |z|}.$$

The inverse of g is given by

$$g^{-1}(w) = \frac{w}{1 + |w|}.$$

Let $gh_i(x_j) = (a_1, a_2, \dots, a_n)$ and $gh_i(x_{j+1}) = (b_1, b_2, \dots, b_n)$. Define the translation function

$$f: \mathbb{R}^n \rightarrow \mathbb{R}^n$$

by $f(w_1, \dots, w_n) = (w_1 + (b_1 - a_1), w_2 + (b_2 - a_2), \dots, w_n + (b_n - a_n))$. Then f is a homeomorphism with

$$f(gh_i(x_j)) = gh_i(x_{j+1}).$$

Moreover, f is homotopic to the identity via the homotopy

$$f_t(w_1, \dots, w_n) = (w_1 + t(b_1 - a_1), \dots, w_n + t(b_n - a_n)), \quad 0 \leq t \leq 1.$$

Thus, we have a homeomorphism for each t

$$g^{-1} \circ f_t \circ g: D^n - S^{n-1} \rightarrow D^n - S^{n-1}$$

that takes $h_i(x_j)$ into $h_i(x_{j+1})$ when $t = 1$. Note further that, for each t , this may be extended to a homeomorphism from D^n to D^n by defining it to be the identity on the boundary (see Exercise 3).

Now define a homotopy $h_t: M \rightarrow M$ by

$$h_t(z) = \begin{cases} z & \text{if } z \in M - U_i \\ h_i^{-1} \circ g^{-1} \circ f_t \circ g \circ h_i(z) & \text{if } z \in U_i. \end{cases}$$

Then each h_t is a homeomorphism, h_0 is the identity and $h_1(x_j) = x_{j+1}$. This completes the inductive step, so that by composing maps and homotopies we may give a homeomorphism homotopic to the identity taking x into y . \square

Note: We actually have proved something stronger than the conclusion of the lemma. If $f, g: X \rightarrow Y$ are homeomorphisms between topological spaces, then f is isotopic to g if there exists a map $F: X \times [0, 1] \rightarrow Y$ such that

- (1) $F(x, 0) = f(x)$;
- (2) $F(x, 1) = g(x)$;
- (3) for $0 \leq t \leq 1$ the map $x \rightarrow F(x, t)$ is a homeomorphism of X onto Y .

The construction used in the theorem makes it evident that the map h is isotopic to the identity.

EXERCISE 2. If M is a connected n -manifold, show that the interior of M , $M - \partial M$, is also connected.

EXERCISE 3. Let (a_1, \dots, a_n) be a point in \mathbb{R}^n and define $f: \mathbb{R}^n \rightarrow \mathbb{R}^n$ by $f(x_1, \dots, x_n) = (x_1 + a_1, \dots, x_n + a_n)$. Using the map $g: D^n - S^{n-1} \rightarrow \mathbb{R}^n$ defined by $g(z) = z/(1 - |z|)$, show that the homeomorphism

$$g^{-1} \circ f \circ g: D^n - S^{n-1} \rightarrow D^n - S^{n-1}$$

may be extended to a homeomorphism $D^n \rightarrow D^n$ by defining it to be the identity on the boundary.

6.5 Theorem. If M is a connected, noncompact n -manifold without boundary, then $H_n(M) = 0$.

Proof. First note that if p is any point in M , the homomorphism $k_*: H_n(M) \rightarrow H_n(M, M - p)$, induced by the inclusion, is identically zero. To check this let $\{z\} \in H_n(M)$ be represented by the cycle z and let $C \subseteq M$ be a compact subset which supports the cycle z .

First suppose $p \in M - C$, so that $\{z\}$ is in the image of the homomorphism

$H_n(M - p) \rightarrow H_n(M)$. Then by the exact sequence of the pair $(M, M - p)$ it follows that $k_*(\{z\}) = 0$.

If $p \in C$, then select a point q with $q \in M - C$. Such a point must exist, since C is compact and M is not. By Lemma 6.4 there is a homeomorphism $h: M \rightarrow M$, homotopic to the identity, with $h(p) = q$. The restriction of h will then yield a homeomorphism from $M - p$ to $M - q$.

From the commutativity of the diagram

$$\begin{array}{ccc} H_n(M) & \xrightarrow{k_*} & H_n(M, M - p) \\ \downarrow h_* = \text{id} & & \downarrow \approx \\ H_n(M) & \xrightarrow{k'_*} & H_n(M, M - q) \end{array}$$

and the fact that $k'_*(\{z\}) = 0$ we conclude that $k_*(\{z\}) = 0$.

Now let $\{z\}$ be an arbitrary homology class as above and cover the compact set C with a finite number of coordinate neighborhoods U_1, \dots, U_k , where each U_i is homeomorphic to an open disk in \mathbb{R}^n . Denoting $V_j = \bigcup_{i=1}^j U_i$, we will show that $\{z\} = 0$ by proving that $\{z\}$ is a boundary in V_k , that is, $H_n(V_k) = 0$.

The argument proceeds by induction on k . For $k = 1$ the result follows from Lemma 6.1. So suppose $H_n(V_m) = 0$ and consider the Mayer-Vietoris sequence for the union $V_m \cup U_{m+1} = V_{m+1}$:

$$\begin{aligned} H_n(V_m) \oplus H_n(U_{m+1}) &\rightarrow H_n(V_{m+1}) \rightarrow H_{n-1}(V_m \cap U_{m+1}) \\ &\rightarrow H_{n-1}(V_m) \oplus H_{n-1}(U_{m+1}). \end{aligned}$$

Now the first term is zero by the inductive hypothesis and Lemma 6.1 and $H_{n-1}(U_{m+1}) = 0$ since U_{m+1} is homeomorphic to an open disk. Thus, to prove that $H_n(V_{m+1}) = 0$ it is sufficient to show that the homomorphism

$$i_*: H_{n-1}(V_m \cap U_{m+1}) \rightarrow H_{n-1}(V_m)$$

is a monomorphism.

So suppose that $i_*(\beta) = 0$. Then there exist elements $\beta' \in H_n(U_{m+1}, V_m \cap U_{m+1})$ and $\beta'' \in H_n(V_m, V_m \cap U_{m+1})$ such that $\Delta_1(\beta') = \beta = \Delta_2(\beta'')$, where Δ_1 and Δ_2 are the respective connecting homomorphisms.

Consider the following diagram:

$$\begin{array}{ccccc} H_n(V_m, V_m \cap U_{m+1}) & \xrightarrow{i_{2*}} & H_n(V_{m+1}, V_m \cap U_{m+1}) & \xrightarrow{i_*} & H_n(M, M - p) \\ \downarrow \Delta_2 & & \uparrow i_{1*} & \swarrow j_* & \uparrow \approx \\ & & & j_* H_n(V_{m+1}) i_{p*} & \\ H_{n-1}(V_m \cap U_{m+1}) & \xleftarrow{\Delta_1} & H_n(U_{m+1}, V_m \cap U_{m+1}) & \xrightarrow{j_{p*}} & H_n(U_{m+1}, U_{m+1} - p) \end{array}$$

Setting $\bar{\beta} = i_{1*}(\beta') - i_{2*}(\beta'')$, observe that $\Delta(\bar{\beta}) = 0$, where Δ is the connect-

ing homomorphism of the pair $(V_{m+1}, V_m \cap U_{m+1})$. Thus, there exists an $\alpha \in H_n(V_{m+1})$ with $j_*(\alpha) = \bar{\beta}$.

Let $p \in U_{m+1} - V_m \cap U_{m+1}$. Then by the remarks at the beginning of the proof, $i_{p*}(\alpha) = 0$. Thus

$$\begin{aligned} 0 &= l_*(j_*(\alpha)) = l_*(\bar{\beta}) = l_*(i_{1*}(\beta') - i_{2*}(\beta'')) \\ &= l_*i_{1*}(\beta') - l_*i_{2*}(\beta''). \end{aligned}$$

Now since $p \notin V_m$, l_*i_{2*} factors through $H_n(M - p, M - p) = 0$, so $l_*i_{2*}(\beta'') = 0$. Hence, $l_*i_{1*}(\beta') = 0$. This implies that $j_{p*}(\beta') = 0$.

It follows from Lemma 6.3 that β' must be zero, hence $\beta = 0$ and i_* is a monomorphism. Therefore, $H_n(V_{m+1}) = 0$ and we have completed the inductive step. □

6.6 Corollary. *Let M be a closed connected n -manifold. If $z \in H_n(M)$ and $p \in M$ such that*

$$i_{p*}: H_n(M) \rightarrow H_n(M, M - p)$$

has $i_{p*}(z) = 0$, then $z = 0$.

Proof. Since $i_{p*}(z) = 0$, there must be an element $z' \in H_n(M - p)$ with z being the image of z' . However, $M - p$ is not compact, so by Theorem 6.5 $H_n(M - p) = 0$. Thus, z' and also z must be zero. □

6.7 Corollary. *If M is a connected n -manifold without boundary, then either*

- (i) $H_n(M) = 0$, or
- (ii) $H_n(M) \approx Z$, and for every $p \in M$ the homomorphism $i_{p*}: H_n(M) \rightarrow H_n(M, M - p)$ is an isomorphism.

Proof. From Corollary 6.6 we have that i_{p*} is a monomorphism. Since $H_n(M, M - p) \approx Z$, it follows that either $H_n(M) = 0$ or $H_n(M) \approx Z$. So suppose $H_n(M) \neq 0$ and let $z \in H_n(M)$ and $w \in H_n(M, M - p)$ be generators for the respective infinite cyclic groups. Then $i_{p*}(z) = \pm m \cdot w$ for some positive integer m . We must show that $m = 1$.

Note that the same proof as for Theorem 6.5 may be given to show that for any abelian group G , $H_n(M; G) = 0$ for M a connected noncompact manifold without boundary. Then consider the diagram

$$\begin{array}{ccc} H_n(M) \otimes Z_m & \xrightarrow{i_{p*} \otimes \text{id}} & H_n(M, M - p) \otimes Z_m \\ \alpha_1 \downarrow \text{mono} & & \alpha_2 \downarrow \text{mono} \\ H_n(M; Z_m) & \xrightarrow{i_{p*} \text{ mono}} & H_n(M, M - p; Z_m) \end{array}$$

where the vertical monomorphisms come from the universal coefficient theorem. The commutativity of the square implies that $i_{p*} \otimes \text{id}$ is a monomorphism. But

$$(i_{p*} \otimes \text{id})(z \otimes 1) = i_{p*}(z) \otimes 1 = \pm m \cdot w \otimes 1 = \pm w \otimes m = 0,$$

so that $z \otimes 1 = 0$. This only happens if $m = 1$. Therefore, i_{p*} is an isomorphism. □

Let M be an n -manifold without boundary. For each $p \in M$ let

$$T_p = H_n(M, M - p) \approx Z$$

and for coefficients in Z_2

$$T_p(Z_2) = H_n(M, M - p; Z_2) \approx Z_2.$$

Define the set

$$\mathcal{T} = \sum_{p \in M} T_p.$$

We want to introduce a topology on the set \mathcal{T} . To do so requires the notion of a proper n -ball. A *proper n -ball* in M is an open set $V \subseteq M$ such that there exists a homeomorphism of D^n onto \bar{V} taking S^{n-1} onto $\bar{V} - V$. For example, the interior of the region shown in Figure 6.11a fails to be a proper n -ball while the interior of the region in Figure 6.11b is a proper n -ball.

EXERCISE 4. Show that if M is an n -manifold without boundary, then the collection of all proper n -balls in M forms a basis for the topology on M .

Now if V is a proper n -ball in M and $p \in V$, then there is an isomorphism

$$j_{p*}: H_n(M, M - V) \xrightarrow{\cong} T_p.$$

As a basis for the topology on \mathcal{T} we take the sets

$$U_{\alpha, V} = \{j_{p*}(\alpha) | p \in V\}$$

as V ranges over all proper n -balls of M and α ranges over all elements for $H_n(M, M - V)$. For example, the choice of a generator for $H_n(M, M - V)$ dictates, via the isomorphisms j_{p*} , a generator for each T_p , and these selected generators form a sheet in \mathcal{T} which is homeomorphic to V . Since this may be

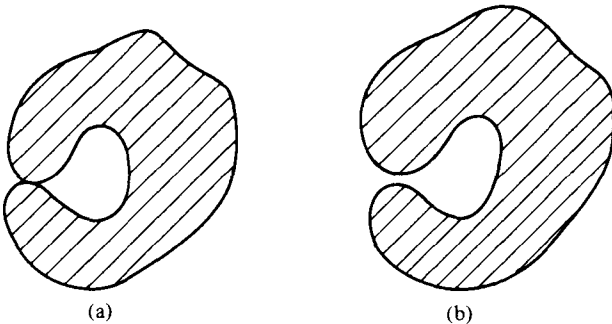

Figure 6.11

done for either generator of $H_n(M, M - V)$ we see that the generators of the T_p form two disjoint sheets each homeomorphic to V .

More generally, if $\tau: \mathcal{T} \rightarrow M$ is the natural projection, it is evident that τ is a local homeomorphism. Each component of \mathcal{T} is a covering space of M with either one or two sheets. In particular the generators of all the T_p form either a double covering of M or two distinct simple coverings. The restriction of τ to this subset of \mathcal{T} is the *orientation double covering* of M . In the case that there are two distinct simple coverings we say that M is *orientable*. An *orientation* of M is a map $s: M \rightarrow \mathcal{T}$ with $\tau \circ s = \text{identity on } M$ and $s(p)$ a generator of T_p for each $p \in M$. Of course, an orientable manifold has two possible orientations.

EXERCISE 5. Let B be the Möbius band so that $M = B - \partial B$ is a 2-manifold without boundary. Prove that M is not orientable by showing that the domain of its orientation double covering is homeomorphic to the annulus $S^1 \times (0, 1)$.

EXERCISE 6. Let M be an n -manifold without boundary and let \hat{M} be the domain of its orientation double covering. Then show that \hat{M} is an orientable n -manifold.

Following the same procedure for the groups $T_p(\mathbb{Z}_2)$, the generators form a simple covering of M so that there always exists a unique \mathbb{Z}_2 -orientation.

If M is a closed n -manifold, a *fundamental class* on M is an element $z \in H_n(M)$ such that

$$i_{p*}: H_n(M) \rightarrow H_n(M, M - p) = T_p$$

has $i_{p*}(z)$ a generator of T_p for each $p \in M$. A cycle representing z is a *fundamental cycle*.

6.8 Lemma. Let M be a closed n -manifold and U be an open subset of M . If an element $x \in H_n(M, U)$ has $j_{p*}(x) = 0$ for all $p \in M - U$, where

$$j_{p*}: H_n(M, U) \rightarrow T_p,$$

then $x = 0$.

Proof. First suppose that $M - U$ is contained in some coordinate neighborhood W . Then consider the commutative diagram

$$\begin{array}{ccc} H_n(W, W \cap U) & \xrightarrow{h_{p*}} & H_n(W, W - p) \\ \cong \downarrow & & \downarrow \cong \\ H_n(M, U) & \xrightarrow{j_{p*}} & H_n(M, M - p) = T_p \end{array}$$

where the vertical homomorphisms are excision isomorphisms. For each $p \in M - U = W - (W \cap U)$, it follows that $j_{p*}(x) = 0$ if and only if h_{p*} kills the preimage of x . Then by Lemma 6.3 the preimage of x must be zero, which implies that $x = 0$.

For the general case, since $M - U$ is compact, we express $M - U$ as the union of a finite number of compact sets, each contained in a coordinate neighborhood. We proceed by induction on the number k of such compact sets. In the previous paragraph we have proved the result for $k = 1$. For the inductive step we use the Mayer–Vietoris sequence

$$H_{n+1}(M, U' \cup U'') \rightarrow H_n(M, U' \cap U'') \rightarrow H_n(M, U') \oplus H_n(M, U''),$$

where U' and U'' are open sets in M , and the fact that $H_{n+1}(M, U' \cup U'') = 0$, which follows by Lemmas 6.1 and 6.5 and the exact sequence of a pair. \square

6.9 Lemma. *Let M be a closed orientable n -manifold with orientation $s: M \rightarrow \mathcal{F}$. Then there exists a class $z \in H_n(M)$ such that $i_{p^*}(z) = s(p) \in T_p$ for all $p \in M$.*

Proof. From our previous observations we know that for each p there exists a proper n -ball V_p about p and an element $x_p \in H_n(M, M - \bar{V}_p)$ such that if $q \in \bar{V}_p$, $j_{q^*}(x_p) = s(q)$. The technique then is to piece together such proper n -balls, using a Mayer–Vietoris sequence and the compactness of M , to construct the desired global homology class.

Since M is compact, there is a finite collection V_1, \dots, V_k of proper n -balls which cover M . Suppose that there is an element

$$z_m \in H_n(M, M - (\bar{V}_1 \cup \dots \cup \bar{V}_m))$$

such that

$$j_{q^*}(z_m) = s(q)$$

for all $q \in \bar{V}_1 \cup \dots \cup \bar{V}_m$. Then consider the relative Mayer–Vietoris sequence

$$\begin{aligned} H_n(M, M - (\bar{V}_1 \cup \dots \cup \bar{V}_{m+1})) \\ \rightarrow H_n(M, M - (\bar{V}_1 \cup \dots \cup \bar{V}_m)) \oplus H_n(M, M - \bar{V}_{m+1}) \\ \rightarrow H_n(M, M - (\bar{V}_1 \cup \dots \cup \bar{V}_m) \cap \bar{V}_{m+1}). \end{aligned}$$

Starting with the element $z_m - x_{m+1}$ in the direct sum, let w be its image in $H_n(M, M - (\bar{V}_1 \cup \dots \cup \bar{V}_m) \cap \bar{V}_{m+1})$. This implies that for all $q \in (\bar{V}_1 \cup \dots \cup \bar{V}_m) \cap \bar{V}_{m+1}$, $j_{q^*}(w) = 0$. Now by Lemma 6.8 it follows that $w = 0$.

Let $z_{m+1} \in H_n(M, M - (\bar{V}_1 \cup \dots \cup \bar{V}_{m+1}))$ be the element which is mapped into $z_m - x_{m+1}$ and note that $j_{q^*}(z_{m+1}) = s(q)$ for all $q \in \bar{V}_1 \cup \dots \cup \bar{V}_{m+1}$. This completes the inductive step and the desired class z is z_k . \square

All of these results are summarized in the following theorem expressing the precise relation between orientation and fundamental class:

6.10 Theorem. *If M is a closed connected orientable n -manifold with orientation $s: M \rightarrow \mathcal{F}$, then there is a unique fundamental class $z \in H_n(M)$ such that $i_{p^*}(z) = s(p)$ for each $p \in M$.*

Proof. This follows immediately from the previous lemmas. From Lemma 6.9 we have the existence of such a fundamental class z . If z' is another such class, then for each $p \in M$

$$i_{p*}(z - z') = s(p) - s(p) = 0$$

so that $z - z' = 0$ by Corollary 6.6. This proves uniqueness. □

EXERCISE 7. Let M_1 be a closed orientable n_1 -manifold and M_2 be a closed orientable n_2 -manifold. Then show $M_1 \times M_2$ is a closed orientable $(n_1 + n_2)$ -manifold.

Our procedure for proving the Poincaré duality theorem follows the style of Milnor [1957] by first establishing a form of the Thom isomorphism. So for the present, we assume that M is a closed, orientable n -manifold with an orientation $s: M \rightarrow \mathcal{T}$. Then by the above exercise, $M \times M$ is a compact, orientable $2n$ -manifold. Define maps $\pi_1, \pi_2: M \times M \rightarrow M$ by projection onto the first or second coordinate, and for any $p \in M$

$$l_p, r_p: M \rightarrow M \times M$$

by $l_p(x) = (p, x)$, $r_p(x) = (x, p)$. Finally, denote by

$$\Delta: M \rightarrow M \times M$$

the diagonal $\Delta(x) = (x, x)$ and note that

$$\pi_1 \circ \Delta = \pi_2 \circ \Delta = \text{identity on } M.$$

6.11 Lemma. Let V be a proper n -ball in M with $p \in V$ corresponding to the origin in D^n . There is a homeomorphism

$$\theta: \pi_1^{-1}(V) = V \times M \rightarrow \pi_1^{-1}(V)$$

such that

- (i) $\pi_1 = \pi_1 \circ \theta$ on all of $\pi_1^{-1}(V)$;
- (ii) $\theta \circ \Delta = r_p$ on V ;
- (iii) $(\pi_2 \circ \theta \circ l_q)_*(s(q)) = s(p)$ for all $q \in V$.

Note: This states that $V \times M$ may be deformed in such a way that the first coordinate is unchanged (i), and the diagonal over V is transformed into the level set $V \times \{p\}$ (ii). Furthermore this is done in such a way as to preserve the orientation in the sense that the composition

$$\begin{aligned} H_n(M, M - q) &\xrightarrow{l_{q*}} H_n(q \times M, q \times (M - q)) \\ &\xrightarrow{\theta_*} H_n(q \times M, q \times (M - p)) \\ &\xrightarrow{\pi_{2*}} H_n(M, M - p) \end{aligned}$$

takes $s(q)$ into $s(p)$ for all q in V .

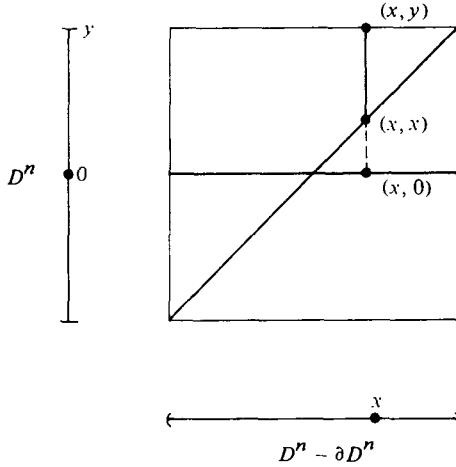

Figure 6.12

Proof. Denote by

$$h: \bar{V} \rightarrow D^n$$

the homeomorphism taking p into the origin. Define a homeomorphism

$$\lambda: (D^n - \partial D^n) \times D^n \rightarrow (D^n - \partial D^n) \times D^n$$

as follows: for $x \in D^n - \partial D^n$, $y \in \partial D^n$, map the entire segment from (x, x) to (x, y) linearly into the segment from $(x, 0)$ to (x, y) (Figure 6.12).

Now define

$$\theta(q, q') = \begin{cases} (q, q') & \text{if } q' \notin V \\ (q, h^{-1}(\lambda(h(q), h(q')))) & \text{for } q' \in V. \end{cases}$$

For fixed $q \in V$, as $q' \in V$ approaches ∂V , $\theta(q, q')$ approaches (q, q') . It follows that θ is a well-defined homeomorphism with the desired properties. \square

For any open set $U \subseteq M$ denote by U^\times the pair

$$U^\times = (\pi_1^{-1}(U), \pi_1^{-1}(U) - \Delta(M)) = (U \times M, U \times M - \Delta(M))$$

and in particular

$$M^\times = (M \times M, M \times M - \Delta(M)).$$

6.12 Lemma

- (i) $H_i(M^\times) = 0$ for $i < n$;
- (ii) $H_0(M) \approx H_n(M^\times)$ under the homomorphism sending the 0-chain represented by $p \in M$ into the relative class represented by $l_{p*}(s(p))$, where

$$l_{p*}: H_n(M, M - p) \rightarrow H_n(M \times M, M \times M - \Delta(M)).$$

Proof. First consider the statement of the lemma with a proper n -ball V replacing M . The homeomorphism θ of Lemma 6.11 induces

$$\theta: V^\times = (V \times M, V \times M - \Delta(M)) \rightarrow V \times (M, M - p),$$

since $\Delta(V)$ is taken into $V \times p$. Therefore, the induced homomorphism on the relative homology groups is an isomorphism. Applying the Künneth formula of Theorem 5.5 to $V \times (M, M - p)$, Statement (i) follows for V^\times

Consider the composition

$$\begin{aligned} H_n(V, V - q) &\xrightarrow{l_{q*}} H_n(V \times M, V \times M - \Delta(M)) \\ &\xrightarrow[\cong]{\theta_*} H_n(V \times (M, M - p)) \xrightarrow{\pi_2^*} H_n(M, M - p). \end{aligned}$$

$$\Downarrow$$

$$H_0(V) \otimes H_n(M, M - p)$$

From Lemma 6.11, Part (iii) we know that $\pi_{2*}\theta_*l_{q*}(s(q)) = s(p)$. The vertical isomorphism follows from the Künneth formula, where $H_0(V) \otimes H_n(M, M - p)$ is the infinite cyclic group generated by $\{q\} \otimes s(p)$. These two isomorphisms imply that Part (ii) holds for V replacing M .

Finally, we again use an inductive procedure to extend to the general case. Suppose that U and V are open sets in M such that the lemma holds for U , V , and $U \cap V$. There is a diagram of Mayer–Vietoris sequences

$$\begin{array}{ccccccc} \cdots \rightarrow & H_0(U \cap V) & \rightarrow & H_0(U) \oplus H_0(V) & \rightarrow & H_0(U \cup V) & \rightarrow 0 \rightarrow \cdots \\ & \downarrow & & \downarrow & & \downarrow & \downarrow \\ \cdots \rightarrow & H_n((U \cap V)^\times) & \rightarrow & H_n(U^\times) \oplus H_n(V^\times) & \rightarrow & H_n((U \cup V)^\times) & \rightarrow H_{n-1}((U \cap V)^\times) \rightarrow \cdots, \end{array}$$

where the vertical homomorphisms are those described in Part (ii). Note that if p and q are in the same path component of U , then it follows from Lemma 6.11, Part (iii) that $l_{p*}(s(p)) = l_{q*}(s(q))$. Applying the five lemma (Exercise 4, Chapter 2) completes the inductive step and, since M is compact, the proof is complete. □

We are now ready to prove the following important theorem which has many applications in algebraic topology.

6.13 Theorem (Thom Isomorphism Theorem). *For a compact oriented n -manifold M without boundary, there is a cohomology class $U \in H^n(M^\times)$ such that for any coefficient group G the homomorphism*

$$\Phi^*: H^k(M; G) \rightarrow H^{n+k}(M^\times; G)$$

given by

$$\Phi^*(x) = U \cup \pi_1^*(x)$$

is an isomorphism. Here the cup product has the form

$$\begin{aligned} H^k(M \times M; G) \otimes H^n(M \times M, M \times M - \Delta(M); Z) \\ \rightarrow H^{n+k}(M \times M, M \times M - \Delta(M); G). \end{aligned}$$

Note: The class $U \in H^n(M^\times)$ is called the *Thom class* of the topological manifold M .

Proof. We prove the theorem for $G = Z$. The general case follows by applying the universal coefficient theorem.

Since $H_i(M^\times) = 0$ for $i < n$, it follows from the universal coefficient theorem that $H^i(M^\times) = 0$ for $i < n$ and $H^n(M^\times) \approx \text{Hom}(H_n(M^\times), Z)$. From Lemma 6.12 we have a natural isomorphism of $H_n(M^\times)$ with $H_0(M)$, hence also of $\text{Hom}(H_n(M^\times), Z)$ with $\text{Hom}(H_0(M), Z)$. Then we define $U \in H^n(M^\times)$ to be the class corresponding to the augmentation homomorphism

$$H_0(M) \rightarrow Z$$

under these isomorphisms. In particular then it follows from Lemma 6.12 that for all $p \in M$ the Kronecker index

$$\langle U, l_{p^*}(s(p)) \rangle = 1.$$

For any open set $V \subseteq M$ we denote by $U_v \in H^n(V^\times)$ the restriction of the Thom class U . There is a cap product

$$H^n(V \times M, V \times M - \Delta(M)) \otimes H_k(V \times M, V \times M - \Delta(M)) \rightarrow H_{k-n}(V \times M)$$

sending $U_v \otimes \alpha$ into $U_v \cap \alpha$. For any $\alpha \in H_k(V^\times)$ define $\Phi_*(\alpha)$ to be the element of $H_{k-n}(V)$ given by $\Phi_*(\alpha) = \pi_{1*}(U_v \cap \alpha)$. Thus

$$\Phi_*: H_*(V^\times) \rightarrow H_*(V)$$

is a natural homomorphism of degree $-n$ between graded groups.

Now restrict to the case of V being a proper n -ball. Under the isomorphism of Lemma 6.11

$$\theta^*: H^n(V \times (M, M - p)) \rightarrow H^n(V^\times),$$

the element $\theta^{*-1}(U_v)$ may be identified via the Künneth formula with $1 \otimes \gamma \in H^0(V) \otimes H^n(M, M - p)$, where γ is a generator of the infinite cyclic group $H^n(M, M - p)$.

By the naturality of the cap product

$$\begin{aligned} \pi_{1*}(U_v \cap \alpha) &= \pi_{1*} \circ \theta_*(\theta^*(\theta^{*-1}(U_v)) \cap \alpha) \\ &= \pi_{1*}(\theta^{*-1}(U_v) \cap \theta_*(\alpha)). \end{aligned}$$

So if $\omega \in H_n(M, M - p)$ is a generator with $\langle \gamma, \omega \rangle = 1$, then

$$\pi_{1*}(U_v \cap \alpha) = \beta,$$

where $\beta \otimes \omega$ corresponds to α under the isomorphisms

$$H_{k-n}(V) \otimes H_n(M, M - p) \xrightarrow{\cong} H_k(V \times (M, M - p)) \xrightarrow{\cong} H_k(V^\times).$$

Therefore, $\Phi_*: H_k(V^\times) \rightarrow H_{k-n}(V)$ is an isomorphism for each k .

If $V_1 \subseteq V_2$ are open sets in M , the restriction of U_{v_2} is U_{v_1} . This fact, together with naturality and the Mayer–Vietoris sequence, may be used in the manner of Lemma 6.12 to extend the result inductively to an isomorphism

$$\Phi_*: H_k(M^\times) \xrightarrow{\cong} H_{k-n}(M).$$

By returning to the chain level we can define the adjoint of Φ_* ; this yields a homomorphism

$$\Phi^*: H^i(M) \rightarrow H^{i+n}(M^\times).$$

Applying the universal coefficient theorem, we see that Φ^* is also an isomorphism. Finally note that

$$\begin{aligned} \langle \Phi^*(x), y \rangle &= \langle x, \Phi_*(y) \rangle \\ &= \langle x, \pi_{1*}(U \cap y) \rangle \\ &= \langle \pi_1^*x, U \cap y \rangle \\ &= \langle U \cup \pi_1^*(x), y \rangle \end{aligned}$$

for any x and y , so that $\Phi^*(x) = U \cup \pi_1^*(x)$. □

EXAMPLE. As an aid to understanding this important theorem, consider the following simple example: Let $M = S^1$ so that $M \times M$ is the two-dimensional torus. Recall from Chapter 5 the determination of the cohomology ring structure in $M \times M$. As before we denote generating 1-cycles in $M \times M$ by $\bar{\alpha}$ and $\bar{\beta}$, and their dual cocycles by α and β (Figure 6.13). It is not difficult to see that $M \times M - \Delta M$ has the homotopy type of S^1 , as is demonstrated in the following deformation (Figure 6.14).

Now given an orientation for $M = S^1$, there is a generator $\bar{a} \in H_1(M)$ such that $i_{p*}(\bar{a}) = s(p)$ for all $p \in M$. Thus, from the commutative diagram

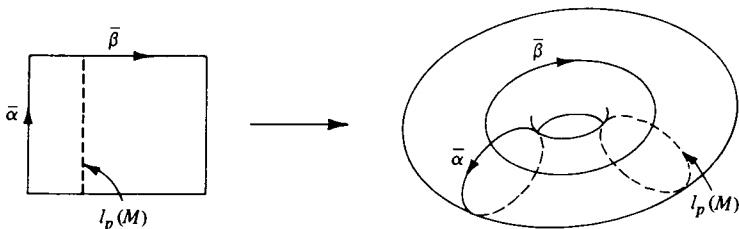

Figure 6.13

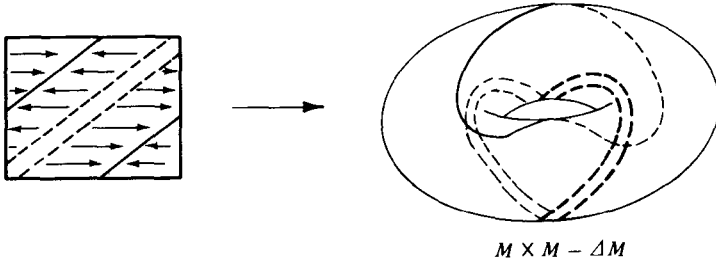

Figure 6.14

$$\begin{array}{ccc}
 H_1(M) & \xrightarrow{i_{p*}} & H_1(M, M - p) \\
 \downarrow l_{p*} & & \downarrow l_{p*} \\
 H_1(M \times M) & \xrightarrow{i_*} & H_1(M^\times)
 \end{array}$$

we see that $l_{p*}(s(p)) = l_{p*}i_{p*}(\bar{a}) = i_*l_{p*}(\bar{a})$. With a possible change in sign resulting from the choice of orientation, we have $l_{p*}(\bar{a}) = \bar{\alpha}$. Thus, the Thom class $U \in H^1(M^\times)$ will have the property that

$$1 = \langle U, l_{p*}s(p) \rangle = \langle U, i_*(\bar{\alpha}) \rangle = \langle i^*U, \bar{\alpha} \rangle.$$

From the exact cohomology sequence of the pair M^\times ,

$$H^1(M^\times) \xrightarrow{i^*} H^1(M \times M) \xrightarrow{j^*} H^1(M \times M - \Delta M),$$

it is not difficult to argue that i^* is a monomorphism and j^* is an epimorphism. Furthermore, $H^1(M \times M)$ is free abelian with basis elements α and β , and the kernel of j^* is infinite cycle generated by $\alpha - \beta$. This uniquely determines the Thom class U corresponding to the given orientation. Changing the orientation of M changes the sign of U .

Finally consider the Thom homomorphism

$$\Phi^*: H^1(M) \rightarrow H^2(M^\times).$$

If a is the generator dual to \bar{a} , $\Phi^*(a) = U \cup \pi_1^*(a)$. Now in $H^1(M \times M)$ we have

$$\langle \pi_1^*(a), m\bar{\alpha} + n\bar{\beta} \rangle = \langle a, \pi_{1*}(m\bar{\alpha} + n\bar{\beta}) \rangle = m,$$

so that $\pi_1^*(a) = \alpha$. Using the isomorphism $H^2(M^\times) \xrightarrow{i^*} H^2(M \times M)$, it follows that

$$\begin{aligned}
 i^*(\Phi^*(a)) &= i^*(U \cup \pi_1^*(a)) = i^*(U \cup \alpha) = i^*(U) \cup \alpha \\
 &= (\alpha - \beta) \cup \alpha = -\beta \cup \alpha,
 \end{aligned}$$

which is a generator of $H^2(M \times M)$. Thus, $\Phi^*(a)$ is a generator of $H^2(M^\times)$ and Φ^* is an isomorphism.

At this point we need another very basic property of topological manifolds.

6.14 Theorem. *If M is a closed topological n -manifold, there exists a topological embedding of M in \mathbb{R}^k for some large value of k . Furthermore, under this embedding there exists an open set U about M such that M is a retract of U , that is, there exists a map $r: U \rightarrow M$ such that $r|_M$ is the identity.*

Proof. See Appendix II. □

6.15 Lemma. *For M a closed manifold, there exists a neighborhood N of $\Delta(M)$ in $M \times M$ such that $\pi_1|_N$ and $\pi_2|_N$ are homotopic as maps from N to M .*

Proof. Applying Theorem 6.14 we embed M in \mathbb{R}^k and let U be a neighborhood of M which retracts onto M . Since M is compact there exists an $\varepsilon > 0$ such that for any points $x, y \in M$ having distance (in \mathbb{R}^k) between x and y less than ε , the segment from x to y lies in U . It is evident then that any two maps into M with the distance between corresponding points less than ε are homotopic in U via the obvious homotopy. Applying the retraction r moves the homotopy into M .

Now the projection maps π_1 and π_2 coincide on $\Delta(M)$ in $M \times M$. Again using compactness, there must exist a neighborhood N of $\Delta(M)$ in $M \times M$ such that the distance between $\pi_1|_N$ and $\pi_2|_N$ is less than ε . It follows then that these restrictions are homotopic in M . □

6.16 Lemma. *Define $t: M \times M \rightarrow M \times M$ by $t(x, y) = (y, x)$ and note that t induces a map of pairs $t: M^\times \rightarrow M^\times$. Then for $x \in H^*(M^\times; G)$, $t^*(x) = (-1)^n x$.*

Proof. First let V be a proper n -ball in M and consider the diagram

$$\begin{array}{ccc} H^n(M \times M, M \times M - \Delta(M)) & \xrightarrow{t^*} & H^n(M \times M, M \times M - \Delta(M)) \\ \downarrow i^* & & \downarrow i^* \\ H^n(V \times V, V \times V - \Delta(V)) & \xrightarrow{t^*} & H^n(V \times V, V \times V - \Delta(V)), \end{array}$$

where the vertical homomorphisms are induced by the inclusion map. Note that $H^n(V \times V, V \times V - \Delta(V))$ is infinite cyclic since $(V \times V, V \times V - \Delta(V))$ has the homotopy type of (D^n, S^{n-1}) . Furthermore, $i^*(U)$ is a generator of this group and $t^*(i^*U) = (-1)^n i^*(U)$. Thus, we conclude that

$$t^*(U) = (-1)^n U.$$

Now let N be a closed neighborhood of $\Delta(M)$ satisfying the requirement of Lemma 6.15. We may further require that N be invariant under t . Then the

diagram

$$\begin{array}{ccccc}
 H^*(M) & \xrightarrow{\pi_1^*} & H^*(M \times M) & \xrightarrow{U \cup} & H^*(M^\times) \\
 \searrow^{(\pi_1|_N)^*} & & \swarrow^{j^*} & & \swarrow^{j^* \approx \text{excision}} \\
 & & H^*(N) & \xrightarrow{j^*(U) \cup} & H^*(N, N - \Delta(M))
 \end{array}$$

is commutative where the composition across the top is Φ^* . Recalling that $\pi_2 = \pi_1 \circ t$ we have

$$\begin{aligned}
 t^*j^*(\Phi^*(x)) &= t^*j^*(U \cup \pi_1^*(x)) = t^*(j^*(U) \cup (\pi_1|_N)^*(x)) \\
 &= t^*j^*(U) \cup (\pi_2|_N)^*(x) = (-1)^n j^*(U) \cup (\pi_2|_N)^*(x)
 \end{aligned}$$

which by Lemma 6.15

$$= (-1)^n j^*(U) \cup (\pi_1|_N)^*(x) = (-1)^n j^*(\Phi^*(x)).$$

Since j^* and Φ^* are isomorphisms, the result follows. □

6.17 Proposition. *If M is a closed n -manifold, then $H_*(M)$ is finitely generated.*

Proof. Using Theorem 6.14 we embed M in a high-dimensional euclidean space \mathbb{R}^m so that some open set N about M in \mathbb{R}^m admits a retraction onto M , $r: N \rightarrow M$. Choose a large m -simplex s^m in \mathbb{R}^m so that M is contained in its interior. By the results of Appendix I there exists an integer k so that mesh $Sd^k s^m$ is less than the distance from M to $\mathbb{R}^m - N$.

Let K be the union of all simplices in $Sd^k s^m$ whose closures intersect M . Then K is a finite CW complex, $M \subseteq K \subseteq N$ and the retraction r restricts to a retraction $r: K \rightarrow M$.

By Proposition 2.23 $H_*(K)$ is finitely generated and by Corollary 1.12 $H_*(M)$ is isomorphic to a direct summand of $H_*(K)$; hence, $H_*(M)$ is finitely generated. □

We are now ready to prove the main theorem of this chapter.

6.18 Poincaré Duality Theorem. *For M a compact connected orientable n -manifold without boundary, with orientation $s: M \rightarrow \mathcal{F}$ and associated fundamental class z , the homomorphism*

$$D: H^k(M; G) \rightarrow H_{n-k}(M; G),$$

given by $D(x) = x \cap z$, is an isomorphism for each k .

Proof. Let \tilde{z} be a cycle in $S_n(M)$ representing z . Then there is a homomorphism of chain complexes

$$D_\#: S^k(M; G) \rightarrow S_{n-k}(M; G)$$

given by cap product with \tilde{z} . Note that $D_{\#}$ commutes with coboundary and boundary operators up to sign and induces D on cohomology and homology.

Now let R be a ring with unit, $x, y \in H^*(M; R)$ and $\alpha, \beta \in H_*(M; R)$. Then there are the elements

$$\alpha \times \beta \in H_*(M \times M; R) \quad \text{and} \quad x \times y = \pi_1^*(x) \cup \pi_2^*(y) \in H^*(M \times M; R).$$

If $U \in H^n(M^{\times})$ is the Thom class of M , denote by \tilde{U} the class $i^*(U)$, where

$$i^*: H^n(M^{\times}) \rightarrow H^n(M \times M)$$

is induced by inclusion. Let ε be a chosen generator for $H_0(M)$.

The homomorphism $i_*: H_n(M \times M) \rightarrow H_n(M^{\times})$ takes $\varepsilon \times z$ into $i_{p*}(s(p))$. Thus

$$\begin{aligned} (6.19) \quad (-1)^n \langle \tilde{U}, z \times \varepsilon \rangle &= \langle \tilde{U}, \varepsilon \times z \rangle \\ &= \langle i^*(U), \varepsilon \times z \rangle \\ &= \langle U, i_{p*}(s(p)) \rangle \\ &= 1. \end{aligned}$$

If $x \in H^r(M; R)$ and $y \in H^s(M; R)$, then we claim that

$$(6.20) \quad \tilde{U} \cup (x \times y) = (-1)^{rs} \tilde{U} \cup (y \times x).$$

In order to give this meaning we must view \tilde{U} as an element of $H^n(M \times M; R)$. This is done by using the coefficient homomorphism $Z \rightarrow R$ given by taking 1 into the unit of the ring R .

Then in the diagram

$$\begin{array}{ccc} H^n(M^{\times}; R) \otimes H^{r+s}(M \times M; R) & \xrightarrow{\cup} & H^{n+r+s}(M^{\times}; R) \\ \downarrow i^* \otimes \text{id} & & \downarrow i^* \\ H^n(M \times M; R) \otimes H^{r+s}(M \times M; R) & \xrightarrow{\cup} & H^{n+r+s}(M \times M; R), \end{array}$$

we have

$$\begin{aligned} (-1)^n U \cup (x \times y) &= t^*(U \cup (x \times y)) \\ &= t^*(U) \cup t^*(x \times y) \\ &= (-1)^{n+rs} U \cup (y \times x). \end{aligned}$$

Therefore

$$\begin{aligned} \tilde{U} \cup (x \times y) &= i^*(U) \cup \text{id}(x \times y) = i^*(U \cup (x \times y)) \\ &= (-1)^{rs} i^*(U \cup (y \times x)) = (-1)^{rs} \tilde{U} \cup (y \times x) \end{aligned}$$

which proves Equation (6.20).

Finally, for $x \in H^k(M; R)$ and $\alpha \in H_k(M; R)$ we have

$$\begin{aligned}
\langle \tilde{U}, D(x) \times \alpha \rangle &= \langle \tilde{U}, (x \cap z) \times \alpha \rangle \\
&= \langle \tilde{U}, (x \times 1) \cap (z \times \alpha) \rangle \\
&= \langle (x \times 1) \cup \tilde{U}, (z \times \alpha) \rangle.
\end{aligned}$$

Then by Equation (6.20)

$$\begin{aligned}
\langle \tilde{U}, D(x) \times \alpha \rangle &= \langle (1 \times x) \cup \tilde{U}, z \times \alpha \rangle \\
&= \langle \tilde{U}, (1 \times x) \cap (z \times \alpha) \rangle \\
&= (-1)^{nk} \langle \tilde{U}, z \times \langle x, \alpha \rangle \cdot \varepsilon \rangle.
\end{aligned}$$

It follows from Equation (6.19) that this last expression is equal to $(-1)^{n(n-k)} \langle x, \alpha \rangle \cdot 1$. We summarize these statements in the following important equation:

$$(6.21) \quad \langle x, \alpha \rangle = (-1)^{n(n-k)} \langle \tilde{U}, D(x) \times \alpha \rangle.$$

For the special case $R = \mathbb{Z}_p$, where p is a prime, the universal coefficient theorem becomes an isomorphism,

$$H^*(M; \mathbb{Z}_p) \approx \text{Hom}_{\mathbb{Z}_p}(H_*(M; \mathbb{Z}_p), \mathbb{Z}_p).$$

Applying this to the above equation we see that $x \neq 0$ implies $D(x) \neq 0$. Therefore

$$D: H^*(M; \mathbb{Z}_p) \rightarrow H_*(M; \mathbb{Z}_p)$$

is a monomorphism. By Proposition 6.17 these are finite-dimensional vector spaces, so since their dimensions must be the same, D must be an isomorphism.

To extend this result to more general coefficient groups we use the method of "algebraic mapping cylinders" [Eilenberg and Steenrod, 1952]. Recall that $D_\#$ is a homomorphism

$$D_\#: S^k(M) \rightarrow S_{n-k}(M)$$

with $D_\# \circ \delta = \partial \circ D_\#$. Define

$$C_{n-k} = S^{k+1}(M) \oplus S_{n-k}(M) \quad \text{or} \quad C_m = S^{n-m+1}(M) \oplus S_m(M),$$

and a boundary operator

$$\bar{\partial}: C_m \rightarrow C_{m-1} = S^{n-m+2}(M) \oplus S_{m-1}(M),$$

by

$$\bar{\partial}(\alpha, \beta) = (-\delta\alpha, \partial\beta + D_\#(\alpha)).$$

Then we check that

$$\begin{aligned}
\bar{\partial} \circ \bar{\partial}(\alpha, \beta) &= \bar{\partial}(-\delta\alpha, \partial\beta + D_\#(\alpha)) \\
&= (\delta\delta\alpha, \partial(\partial\beta + D_\#(\alpha)) - D_\#\delta(\alpha))
\end{aligned}$$

$$\begin{aligned}
 &= (0, \partial D_{\#}(x) - D_{\#}\delta(x)) \\
 &= 0.
 \end{aligned}$$

Hence, $\{C_m, \bar{\partial}\}$ defines a chain complex C .

There is a short exact sequence

$$0 \rightarrow S_m(M) \xrightarrow{\text{incl}} C_m \xrightarrow{\text{proj}} S^{n-m+1}(M) \rightarrow 0$$

that determines a short exact sequence of chain complexes (the second homomorphism will be a chain map up to sign only, but this will be sufficient for our purposes). Therefore, we have a long exact sequence of homology groups. What is the connecting homomorphism?

Let $y \in S^{n-m+1}(M)$ with $\delta y = 0$. Pick the element $(y, 0) \in C_m$ that projects onto y . Then

$$\bar{\partial}(y, 0) = (-\delta y, D_{\#}(y)) = (0, D_{\#}(y))$$

and the element in $S_{m-1}(M)$ having this as its image is $D_{\#}(y)$. Thus the connecting homomorphism for the sequence is D and the sequence has the form

$$\cdots \rightarrow H^{n-m}(M) \xrightarrow{D} H_m(M) \rightarrow H_m(C) \rightarrow H^{n-m+1}(M) \xrightarrow{D} H_{m-1}(M) \rightarrow \cdots.$$

Now we may identify $S^k(M; Z_p)$ with $S^k(M) \otimes Z_p$, so that for each prime p we have a long exact sequence

$$\cdots \rightarrow H^{n-m}(M; Z_p) \xrightarrow{D} H_m(M; Z_p) \rightarrow H_m(C; Z_p) \rightarrow H^{n-m+1}(M; Z_p) \rightarrow \cdots.$$

In the sequence, D is an isomorphism wherever it occurs. Hence, $H_m(C; Z_p) = 0$ for all integers m and primes p . But since $H_m(C)$ is finitely generated, it follows from the universal coefficient theorem that $H_m(C) = 0$ for all m . Thus, the first sequence shows D to be an isomorphism for integral coefficients. This same technique shows D to be an isomorphism for G any finitely generated abelian group.

Finally, to extend to the general case, the fact that $H_*(M)$ is finitely generated implies that $H_*(M; G)$ is the direct limit of $\{H_*(M; G')\}$ where G' ranges over the finitely generated subgroups of G . Since D commutes with coefficient homomorphisms, we conclude that D is an isomorphism for general abelian groups G . □

Note: The essence of the proof is the relationship between the Thom class and the duality homomorphism. Specifically, if x is a cohomology class and α is an homology class, the Kronecker index of x on α is, up to sign, the same as the Kronecker index of the “restricted” Thom class \bar{U} on the external homology product $D(x) \times \alpha$.

Since all manifolds are orientable when the coefficient group is Z_2 , we may duplicate the previous proof to establish:

6.22 Theorem. For M a closed connected n -manifold with Z_2 -fundamental class $z_2 \in H_n(M; Z_2)$, the homomorphism

$$D: H^k(M; Z_2) \rightarrow H_{n-k}(M; Z_2),$$

given by $D(x) = x \cap z_2$, is an isomorphism. \square

We now turn to the relative case, that is, the duality theorem for a manifold with boundary. Therefore, let M be a compact manifold with boundary ∂M . The structures that were defined previously, the local homology groups T_p and the orientation covering \mathcal{T} with projection τ , may still be defined for points $p \in M - \partial M$. We define $(M, \partial M)$ to be *orientable* if there exists a continuous map $s: M - \partial M \rightarrow \mathcal{T}$ with $\tau \circ s = \text{identity}$ and $s(p)$ a generator of T_p for each p in $M - \partial M$.

One of the most useful tools in studying manifolds with boundary is the “collaring theorem,” which states that there is a neighborhood of the boundary which resembles a collar, that is, it is homeomorphic to the cartesian product of the boundary and an interval. In its topological form it is due to Brown [1962].

6.23 Topological Collaring Theorem. If M is a topological manifold with boundary ∂M , then there exists a neighborhood W of ∂M in M such that W is homeomorphic to $\partial M \times [0, 1]$ in such a way that ∂M corresponds naturally with $\partial M \times 0$.

Proof. See Appendix II. \square

If M is a manifold with boundary, define the “double” of M to be the manifold \hat{M} formed by identifying two copies of M along ∂M .

EXERCISE 8. Show that $(M, \partial M)$ is orientable if and only if \hat{M} is orientable.

EXERCISE 9. Show that if $(M, \partial M)$ is orientable, then ∂M is an orientable manifold without boundary. Is the converse true?

6.24 Theorem. If $(M, \partial M)$ is a compact connected orientable n -manifold with orientation s , then there exists a unique fundamental class $z \in H_n(M, \partial M)$ such that for each $p \notin M - \partial M$, $j_{p*}(z) = s(p)$. Furthermore, if $\Delta: H_n(M, \partial M) \rightarrow H_{n-1}(\partial M)$ is the connecting homomorphism, then $\Delta(z)$ is a fundamental class of ∂M , that is, it restricts to a fundamental class on each component of ∂M .

Proof. Since \hat{M} is orientable, there exists a fundamental class $\hat{z} \in H_n(\hat{M})$ such that $\hat{j}_{p*}(\hat{z}) = \hat{s}(p)$ for all $p \in \hat{M}$. Then we define z to be the image of \hat{z} under the composition

$$H_n(\hat{M}) \rightarrow H_n(\hat{M}, \hat{M} - (M - \partial M)) \approx H_n(M, \partial M),$$

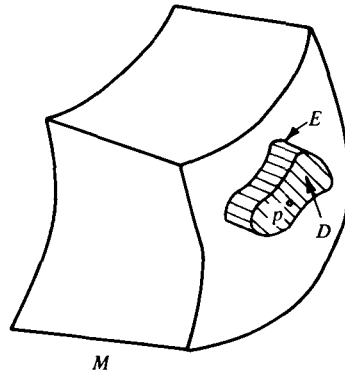

Figure 6.15

where the second homomorphism is the inverse of an excision isomorphism. This gives the existence of the desired fundamental class z .

Let D be a proper $(n - 1)$ -ball in ∂M . If W is a collar for ∂M in M (Theorem 6.23), then under the homeomorphism $W \approx \partial M \times I$ there is an n -cell E corresponding to $D \times I$ (Figure 6.15). For any point p in the interior, D^0 , of the $(n - 1)$ -cell D in ∂M we have the following diagram:

$$\begin{array}{ccccc}
 H_n(M, \partial M) & \xrightarrow{i_*} & H_n(M, M - E^0) & \xleftarrow[\cong]{k_*} & H_n(E, \partial E) \\
 \downarrow \Delta & & \downarrow \Delta & & \downarrow \Delta \\
 H_{n-1}(\partial M) & \xrightarrow{i_*} & H_{n-1}(M - E^0) & \xleftarrow{k'_*} & H_{n-1}(\partial E) \\
 \downarrow j_{p*} & & \downarrow & & \downarrow \cong \\
 H_{n-1}(\partial M, \partial M - p) & \xrightarrow{\cong} & H_{n-1}(M - E^0, (M - E^0) - p) & \xleftarrow{\cong} & H_{n-1}(\partial E, \partial E - p)
 \end{array}$$

in which each rectangle commutes and the horizontal isomorphisms follow by excision.

If q is a point in E^0 , the factorization

$$\begin{array}{ccc}
 H_n(M, \partial M) & \xrightarrow{j_{q*}} & H_n(M, M - q) \\
 & \searrow i_* & \nearrow \\
 & & H_n(M, M - E^0)
 \end{array}$$

and the fact that $j_{q*}(z)$ is the generator $s(q)$ imply that $i_*(z)$ is a generator for the infinite cyclic group $H_n(M, M - E^0)$. Thus, there exists a generator z' for $H_n(E, \partial E)$ such that $k_*(z') = i_*(z)$.

From the diagram $k'_*\Delta(z') = i_*\Delta(z)$ and hence the images of $\Delta(z)$ and $\Delta(z')$ in the infinite cyclic group $H_{n-1}(M - E^0, (M - E^0) - p)$ must coincide. Since

the image of $\Delta(z')$ is a generator, so is the image of $\Delta(z)$. Therefore, $j_{p*}(\Delta(z))$ is a generator of $H_{n-1}(\partial M, \partial M - p)$ and $\Delta(z)$ must be a fundamental class for ∂M .

To prove uniqueness, note first that if W is a collar for ∂M , then both M and $M - \partial M$ are homotopy equivalent to $M - W^0$. Thus

$$H_n(M) \approx H_n(M - \partial M) = 0$$

by Theorem 6.5. So suppose z and w are fundamental classes in $H_n(M, \partial M)$ corresponding to the orientation s . Since $\Delta(z)$ and $\Delta(w)$ are fundamental classes in $H_{n-1}(\partial M)$ corresponding to the orientation induced by s on ∂M , the restrictions of $\Delta(z)$ and $\Delta(w)$ to each component of ∂M must agree by Theorem 6.10. Thus, $z - w$ is in the kernel of Δ . By exactness and the fact that $H_n(M) = 0$ it follows that $z = w$. \square

6.25 Poincaré–Lefschetz Duality Theorem. *Let $(M, \partial M)$ be a compact orientable n -manifold with fundamental class $z \in H_n(M, \partial M)$. Then the duality maps*

$$D: H^k(M, \partial M) \rightarrow H_{n-k}(M) \quad \text{and} \quad D: H^k(M) \rightarrow H_{n-k}(M, \partial M)$$

given by taking the cap product with z are both isomorphisms.

Proof. In \hat{M} let M_1 and M_2 denote the two copies of M (Figure 6.16). There exists a two-sided collaring N of ∂M in \hat{M} . That is, N is homeomorphic to $\partial M \times I$, where $I = [-1, 1]$, with ∂M corresponding to $\partial M \times \{0\}$. Note that ∂N is homeomorphic to $\partial M \times \partial I$.

For $i = 1, 2$ consider the following diagram:

$$\begin{array}{ccc}
 H^k(M) & \xleftarrow[\cong]{j^*} & H^k(M_i \cup N) \\
 \downarrow D = \cap z & & \downarrow \cap j_*(z) \\
 H_{n-k}(M, \partial M) & \xrightarrow[\cong]{j_*} & H_{n-k}(M_i \cup N, \partial(M_i \cup N))
 \end{array}
 \begin{array}{c}
 \nearrow D_i \\
 \searrow \cong \text{excision} \\
 H_{n-k}(\hat{M}, M_{i \pm 1} - N^0)
 \end{array}$$

where D_i is defined to make the triangle commute. Since j is the inclusion

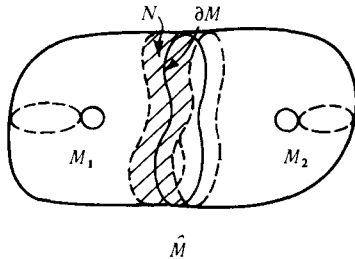

Figure 6.16

map, the rectangle commutes by the naturality of the cap product; that is,

$$j_*(j^*(x) \cap z) = x \cap j_*(z).$$

On the other hand, if $\sigma \in H_1(I, \partial I)$ is a generator, and ε is the element of $H^0(I)$ having $\varepsilon \cap \sigma = \sigma$, then we have the following diagram:

$$\begin{array}{ccc} H^k(\partial M) & \xrightarrow{\cong \times \varepsilon} & H^k(\partial M \times I) = H^k(N) \\ \downarrow \cong \cap \Delta z & & \downarrow \cap (\Delta z \times \sigma) \\ H_{n-k-1}(\partial M) & \xrightarrow{\cong \times \sigma} & H_{n-k}(\partial M \times (I, \partial I)) = H_{n-k}(N, \partial N) \end{array} \begin{array}{c} \searrow \bar{D} \\ \nearrow \cong \text{excision} \\ \rightarrow H_{n-k}(\hat{M}, \hat{M} - N^0) \end{array}$$

where, once again, \bar{D} is defined to make the diagram commute. The rectangle commutes since

$$(x \times \varepsilon) \cap (\Delta z \times \sigma) = (x \cap \Delta z) \times (\varepsilon \cap \sigma) = (x \cap \Delta z) \times \sigma.$$

Note further that since Δz is a fundamental class for ∂M , it follows from Theorem 6.18 that \bar{D} is an isomorphism.

These homomorphisms may be used to connect the following Mayer-Vietoris sequences:

$$\begin{array}{ccccccc} \cdots & \rightarrow & H^k(\hat{M}) & \longrightarrow & H^k(M_1 \cup N) \oplus H^k(M_2 \cup N) & & \\ & & \downarrow \hat{D} & & \downarrow D_1 \oplus D_2 & & \\ \cdots & \rightarrow & H_{n-k}(\hat{M}) & \rightarrow & H_{n-k}(\hat{M}, M_2 - N^0) \oplus H_{n-k}(\hat{M}, M_1 - N^0) & & \\ & & & \rightarrow & H^k(N) \rightarrow \cdots & & \\ & & & & \downarrow \bar{D} & & \\ & & & & H_{n-k}(\hat{M}, \hat{M} - N^0) \rightarrow \cdots, & & \end{array}$$

where \hat{D} is given by taking the cap product with \hat{z} , the fundamental class for \hat{M} which is associated with z . It can be checked that each rectangle commutes up to sign. Since \hat{D} and \bar{D} are isomorphisms, it follows by the five lemma (Exercise 4, Chapter 2) that $D_1 \oplus D_2$ is an isomorphism. Going back to the first diagram, the fact that D_1 is an isomorphism implies that

$$D: H^k(M) \rightarrow H_{n-k}(M, \partial M)$$

is an isomorphism for each k .

Finally, it follows from the diagram

$$\begin{array}{ccccccc} \cdots & \rightarrow & H^{k-1}(\partial M) & \longrightarrow & H^k(M, \partial M) & \longrightarrow & H^k(M) \rightarrow \cdots \\ & & \downarrow \cong \cap \Delta z & & \downarrow \cap z & & \downarrow \cong \cap z \\ \cdots & \rightarrow & H_{n-k}(\partial M) & \longrightarrow & H_{n-k}(M) & \longrightarrow & H_{n-k}(M, \partial M) \rightarrow \cdots \end{array}$$

and another application of the five lemma that

$$D: H^k(M, \partial M) \rightarrow H_{n-k}(M)$$

is an isomorphism. \square

EXERCISE 10. Suppose M is a compact connected oriented n -manifold with $\partial M = M_1 \cup M_2$, the disjoint union of two closed $(n-1)$ -manifolds. If $z \in H_n(M, \partial M)$ is a fundamental class, show that there is a suitably defined cap product which yields an isomorphism

$$H^k(M, M_1) \xrightarrow{\cong} H_{n-k}(M, M_2)$$

given by capping with z .

In the remainder of this chapter we will give a number of immediate applications of the Poincaré duality theorem. We make no attempt to be complete in this sense, because many of the known facts about manifolds are related to this theorem.

6.26 Lemma. *If M is a closed connected oriented n -manifold, then $H_{n-1}(M)$ is free abelian.*

Proof. Suppose this is not true. Since $H_{n-1}(M)$ is finitely generated, it must contain a direct summand isomorphic to Z_p for some integer $p > 1$. Thus

$$H_n(M) \approx Z \quad \text{and} \quad H_{n-1}(M) \approx Z_p \oplus A$$

for some abelian group A . By the universal coefficient theorem

$$\begin{aligned} H_n(M; Z_p) &\approx H_n(M) \otimes Z_p \oplus \text{Tor}(H_{n-1}(M), Z_p) \\ &\approx Z_p \oplus Z_p \oplus \text{Tor}(A, Z_p). \end{aligned}$$

Now from our previous observations we know that the inclusion map induces a monomorphism

$$H_n(M; Z_p) \rightarrow H_n(M, M-x; Z_p) \approx Z_p$$

for any point $x \in M$. This implies the existence of a monomorphism

$$Z_p \oplus Z_p \oplus \text{Tor}(A, Z_p) \rightarrow Z_p,$$

which is impossible. Thus, $H_{n-1}(M)$ is free abelian. \square

It follows immediately from Lemma 6.26 that if M is a closed, connected, oriented n -manifold,

$$\text{Ext}(H_{n-1}(M), Z) = 0$$

so that

$$H^n(M) \approx \text{Hom}(H_n(M), Z),$$

which is infinite cycle. If $z \in H_n(M)$ is the fundamental class corresponding to the given orientation, define $\alpha \in H^n(M)$ to be the “dual” of z in the sense that $\langle \alpha, z \rangle = 1$, so α is a generator for $H^n(M)$.

For any integer q define a pairing

$$H^q(M) \otimes H^{n-q}(M) \rightarrow Z$$

by sending $x \otimes y$ into the integer $\langle x \cup y, z \rangle$. Note that if $r \cdot x = 0$ in $H^q(M)$ for some integer $r \neq 0$, then $(r \cdot x) \cup y = r \cdot (x \cup y) = 0$; hence, $x \cup y = 0$ because $H^n(M)$ is infinite cyclic. Similarly $x \cup y = 0$ if y has finite order.

On the other hand, suppose that $x \in H^q(M)$ does not have finite order. From the universal coefficient theorem the homomorphism

$$H^q(M) \rightarrow \text{Hom}(H_q(M), Z),$$

sending x into the homomorphism $w \rightarrow \langle x, w \rangle$, must take x into a nontrivial homomorphism. Thus, there exists an element $w \in H_q(M)$ with $\langle x, w \rangle \neq 0$. Furthermore this is a split monomorphism, so that if x generates a direct summand of $H^q(M)$, then there exists an element $w \in H_q(M)$ with $\langle x, w \rangle = 1$.

Now by the Poincaré duality theorem there is an element $y \in H^{n-q}(M)$ with $y \cap z = w$. Then

$$\langle y \cup x, z \rangle = \langle x, y \cap z \rangle = \langle x, w \rangle \neq 0$$

and so $x \cup y \neq 0$. This completes the proof of the following:

6.27 Proposition. *If M is a closed connected oriented n -manifold and $A_q \subseteq H^q(M)$ is the torsion subgroup, then there is a nonsingular dual pairing*

$$H^q(M)/A_q \otimes H^{n-q}(M)/A_{n-q} \rightarrow Z. \quad \square$$

6.28 Corollary. *If $a \in H^2(\mathbb{C}P(n))$ is a generator, then $a^k \in H^{2k}(\mathbb{C}P(n))$ is a generator for $1 \leq k \leq n$.*

Proof. $\mathbb{C}P(n)$ is an orientable, compact, connected $2n$ -manifold whose cohomology is given by

$$H^m(\mathbb{C}P(n)) \approx \begin{cases} Z & \text{for } m \text{ even, } 0 \leq m \leq 2n \\ 0 & \text{otherwise.} \end{cases}$$

We prove the result by induction on n . It is obviously true for $n = 1$, so suppose it is true for $n - 1 \geq 1$, and consider the inclusion

$$i: \mathbb{C}P(n - 1) \subseteq \mathbb{C}P(n)$$

of the finite subcomplex which contains all cells of $\mathbb{C}P(n)$ except the one cell of dimension $2n$. From the exact sequence of the pair

$$\begin{aligned} \cdots \rightarrow H^{2k}(\mathbb{C}P(n), \mathbb{C}P(n - 1)) &\rightarrow H^{2k}(\mathbb{C}P(n)) \xrightarrow{i^*} H^{2k}(\mathbb{C}P(n - 1)) \\ &\rightarrow H^{2k-1}(\mathbb{C}P(n), \mathbb{C}P(n - 1)) \rightarrow \cdots \end{aligned}$$

we see that i^* is an isomorphism for $2k < 2n$. Since $i^*(a)$ generates $H^2(\mathbb{C}P(n-1))$, the inductive hypothesis implies that $[i^*(a)]^k$ generates $H^{2k}(\mathbb{C}P(n-1))$ for all $k < n$. Now i^* is a ring homomorphism, so a^k must generate $H^{2k}(\mathbb{C}P(n))$ for $k < n$.

Finally, by Proposition 5.27 there is an element $b \in H^{2n-2}(\mathbb{C}P(n))$ with $a \cup b$ generating $H^{2n}(\mathbb{C}P(n))$. This b must generate $H^{2n-2}(\mathbb{C}P(n))$ so that $b = \pm a^{n-1}$. Therefore, $a \cup b = \pm a^n$ is a generator of $H^{2n}(\mathbb{C}P(n))$. This completes the proof. \square

Note that this completely describes the structure of the cohomology ring of $\mathbb{C}P(n)$.

6.29 Corollary. $H^*(\mathbb{C}P(n))$ is a polynomial ring over the integers with one generator a in dimension two, subject to the relation $a^{n+1} = 0$. \square

Now let R be a field and M be a closed, connected, oriented manifold. As we observed previously

$$H^n(M; R) \approx \text{Hom}_R(H_n(M; R), R)$$

and

$$H^n(M; R) \approx R, \quad H_n(M; R) \approx R.$$

Denote by $z_R \in H_n(M; R)$ a generator as an R -module. Then a slight variation of the Poincaré duality theorem states that the homomorphism

$$H^q(M; R) \rightarrow H_{n-q}(M; R),$$

given by sending a into $a \cap z_R$, is an isomorphism. The technique of Proposition 6.27 may now be used to prove the following.

6.30 Proposition. The pairing $H^q(M; R) \otimes H^{n-q}(M; R) \rightarrow R$ given by sending $x \otimes y$ into $\langle x \cup y, z_R \rangle \in R$ is a nonsingular dual pairing. \square

6.31 Corollary. If M is a closed, connected n -manifold, then

$$H^q(M; Z_2) \otimes H^{n-q}(M; Z_2) \rightarrow Z_2$$

is a nonsingular dual pairing. \square

6.32 Corollary. If $a \in H^1(\mathbb{R}P(n); Z_2)$ is a generator, then a^k generates $H^k(\mathbb{R}P(n); Z_2)$ for $1 \leq k \leq n$. Thus, $H^*(\mathbb{R}P(n); Z_2)$ is a polynomial ring over Z_2 with one generator a in dimension one, subject to the relation $a^{n+1} = 0$. \square

Similar arguments may be used to compute the cohomology ring of quaternionic projective space $\mathbb{H}P(n)$.

6.33 Corollary. $H^*(\mathbb{H}P(n))$ is a polynomial ring over the integers with one generator a in dimension four subject to the relation $a^{n+1} = 0$. \square

With these results we may now establish the existence of certain maps having odd Hopf invariant (see Chapter 5).

6.34 Corollary. There exist maps $S^3 \rightarrow S^2$, $S^7 \rightarrow S^4$, and $S^{15} \rightarrow S^8$ having Hopf invariant 1.

Proof. Let $f: S^3 \rightarrow S^2$ be the Hopf map of Chapter 2. Recall that S_f^2 is homeomorphic to $\mathbb{C}P(2)$. So if b is a generator of $H^2(S_f^2)$ and a is a generator of $H^4(S_f^2)$, then $b^2 = \pm a$ by Corollary 6.29. Thus, $H(f) = \pm 1$. Now the results of Exercise 8 (i) of Chapter 5 indicate how to alter f , if necessary, to give a map with Hopf invariant 1.

The cases $S^7 \rightarrow S^4$ and $S^{15} \rightarrow S^8$ follow by applying the same approach to the quaternions and the Cayley numbers, respectively. \square

In order to develop some further applications we must introduce some basic facts about bilinear forms. Let V be a real vector space of finite dimension. A bilinear form

$$\Phi: V \times V \rightarrow \mathbb{R}$$

is *nonsingular* if $\Phi(x, y) = 0$ for all y in V implies $x = 0$.

EXERCISE 11. Show that this is equivalent to requiring that $\Phi(x, y) = 0$ for all x in V imply $y = 0$.

The form Φ is *symmetric* if $\Phi(x, y) = \Phi(y, x)$; it is *antisymmetric* if $\Phi(x, y) = -\Phi(y, x)$, for all x and y in V .

EXAMPLE. Let $V = \mathbb{R}^2$ and denote its points by (x, y) . Define

$$\Phi((x, y), (x', y')) = \det \begin{pmatrix} x & y \\ x' & y' \end{pmatrix}.$$

This is a nonsingular, antisymmetric bilinear form.

Given any bilinear form Φ on $V \times V$ we may write Φ uniquely as $\Phi = \Phi' + \Phi''$, where Φ' is symmetric and Φ'' is antisymmetric. To see this we set

$$\Phi'(x, y) = \frac{1}{2}[\Phi(x, y) + \Phi(y, x)]$$

and

$$\Phi''(x, y) = \frac{1}{2}[\Phi(x, y) - \Phi(y, x)].$$

Let Φ be antisymmetric on $V \times V$. Then $\Phi(x, x) = 0$ for all $x \in V$. If $x_1 \in V$ has $\Phi(x_1, y) \neq 0$ for some y , then obviously there exists an element y_1 in V with

$$\Phi(x_1, y_1) = 1.$$

Define V_1 to be the subspace of V given by

$$V_1 = \{x \in V \mid \Phi(x, x_1) = 0 \text{ and } \Phi(x, y_1) = 0\}.$$

This linear subspace may be identified with the kernel of the linear transformation

$$\theta: V \rightarrow \mathbb{R}^2$$

given by $\theta(x) = (\Phi(x, x_1), \Phi(x, y_1))$. Note that since $\theta(x_1) = (0, 1)$ and $\theta(y_1) = (-1, 0)$, the transformation is an epimorphism. Therefore, the dimension of V_1 is equal to dimension $V - 2$. By repeating this process using the subspace V_1 to produce a subspace V_2 , and so forth, we will eventually either exhaust V or reach a subspace with the property that the product of any pair of its vectors is zero.

Thus, there is a basis for V of the form

$$x_1, y_1, x_2, y_2, \dots, x_k, y_k, z_1, \dots, z_s$$

for which $\Phi(x_i, y_i) = 1 = -\Phi(y_i, x_i)$, and any other pair of basis vectors have product zero.

6.35 Lemma. *If $\Phi: V \times V \rightarrow \mathbb{R}$ is nonsingular and antisymmetric, then the dimension of V is even.*

Proof. This follows from the above, since $s = 0$. □

6.36 Corollary. *If M is a closed, oriented manifold of dimension $4k + 2$, then $\chi(M)$ is even.*

Proof. Recall that the Euler characteristic is given by

$$\chi(M) = \sum_{i=0}^{4k+2} (-1)^i \dim H_i(M; \mathbb{R}).$$

By the universal coefficient theorem this may also be expressed as the sum

$$\chi(M) = \sum_{i=0}^{4k+2} (-1)^i \dim H^i(M; \mathbb{R}).$$

Since M is closed and oriented, the Poincaré duality theorem implies

$$H^i(M; \mathbb{R}) \approx H_{4k+2-i}(M; \mathbb{R}) \approx \text{Hom}(H^{4k+2-i}(M; \mathbb{R}), \mathbb{R}).$$

Therefore, $\dim H^i(M; \mathbb{R}) = \dim H^{4k+2-i}(M; \mathbb{R})$. As a result the entries in the second sum are paired up, except in the middle dimension, so that

$$\sum_{i \neq 2k+1} (-1)^i \dim H^i(M; \mathbb{R})$$

is even.

Finally note that there is a bilinear form

$$\Phi: H^{2k+1}(M; \mathbb{R}) \times H^{2k+1}(M; \mathbb{R}) \rightarrow \mathbb{R}$$

defined by $\Phi(x, y) = \langle x \cup y, z_{\mathbb{R}} \rangle \in \mathbb{R}$. By Proposition 6.30 this is nonsingular, and since x and y are both odd dimensional, it is antisymmetric. Thus, by Lemma 6.35 the dimension of $H^{2k+1}(M; \mathbb{R})$ is even and $\chi(M)$ is even. \square

6.37 Corollary. *If M is a closed manifold of dimension $2k + 1$, then $\chi(M) = 0$.*

Proof. Since $H_i(M)$ is a finitely generated abelian group for each i , we may write

$$H_i(M) \approx A_i \oplus B_i \oplus C_i,$$

where A_i is free abelian of rank r_i , B_i is a direct sum of s_i cyclic groups of order a power of two, and C_i is a direct sum of cyclic groups of odd order. Note that

$$\chi(M) = \sum_{i=0}^{2k+1} (-1)^i r_i.$$

By the universal coefficient theorem

$$\begin{aligned} \dim H_i(M; \mathbb{Z}_2) &= \dim(H_i(M) \otimes \mathbb{Z}_2) + \dim(\text{Tor}(H_{i-1}(M), \mathbb{Z}_2)) \\ &= (r_i + s_i) + (s_{i-1}). \end{aligned}$$

Thus

$$\begin{aligned} \sum_{i=0}^{2k+1} (-1)^i \dim H_i(M; \mathbb{Z}_2) &= \sum_{i=0}^{2k+1} (-1)^i [r_i + s_i + s_{i-1}] \\ &= \sum_{i=0}^{2k+1} (-1)^i r_i = \chi(M). \end{aligned}$$

On the other hand, by the Poincaré duality theorem

$$H_i(M; \mathbb{Z}_2) \approx H^{2k+1-i}(M; \mathbb{Z}_2) \approx \text{Hom}(H_{2k+1-i}(M; \mathbb{Z}_2), \mathbb{Z}_2)$$

so that

$$\dim H_i(M; \mathbb{Z}_2) = \dim H_{2k+1-i}(M; \mathbb{Z}_2).$$

Since i and $2k + 1 - i$ have different parity, these appear in the sum with opposite signs. Therefore

$$\chi(M) = \sum_{i=0}^{2k+1} (-1)^i \dim H_i(M; \mathbb{Z}_2) = 0. \quad \square$$

Note: This result is obviously false for even-dimensional manifolds since $\chi(S^{2n}) = 2$, $\chi(\mathbb{R}P(2n)) = 1$, and $\chi(\mathbb{C}P(n)) = n + 1$. The vanishing of the Euler characteristic is a useful fact in differential geometry, as is seen in the following basic theorem: a closed differentiable manifold M admits a nonzero vec-

tor field if and only if $\chi(M) = 0$. Thus, Corollary 6.37 implies that any odd-dimensional, closed, differentiable manifold admits a nonzero vector field. We shall return to this subject in Chapter 7.

Now suppose that $\Phi: V \times V \rightarrow \mathbb{R}$ is symmetric. Then since

$$\Phi(x + y, x + y) = \Phi(x, x) + 2\Phi(x, y) + \Phi(y, y)$$

or

$$\Phi(x, y) = \frac{1}{2}[\Phi(x + y, x + y) - \Phi(x, x) - \Phi(y, y)],$$

it follows that if Φ is nontrivial, there exists an $x_1 \in V$ with $\Phi(x_1, x_1) \neq 0$. We may as well assume $\Phi(x_1, x_1) = \pm 1$. Consider the homomorphism

$$\alpha: V \rightarrow \mathbb{R}$$

given by $\alpha(x) = \Phi(x, x_1)$. This is an epimorphism since $\alpha(x_1) = \pm 1$, so if V_1 is the kernel of α , the dimension of V_1 is one less than the dimension of V . By applying the same analysis to V_1 to give an element x_2 , and continuing the process, we produce a basis for V which may be renumbered so as to have the form $x_1, \dots, x_r, x_{r+1}, \dots, x_{r+s}, x_{r+s+1}, \dots, x_{r+s+t}$, where

$$\Phi(x_i, x_i) = \begin{cases} 1 & \text{if } 1 \leq i \leq r \\ -1 & \text{if } r < i \leq r + s \\ 0 & \text{if } r + s < i \leq r + s + t, \end{cases}$$

and any other pair has product zero.

EXERCISE 12. Show that the numbers r and s are invariants of the symmetric form Φ ; that is, that they are independent of the various choices made.

The *signature* of a symmetric form Φ is the integer $r - s$. If Φ is an arbitrary bilinear form, then we write $\Phi = \Phi' + \Phi''$ with Φ' symmetric and Φ'' anti-symmetric. We then define the signature of Φ to be the signature of Φ' .

Let M be a closed, oriented n -manifold. Define the *index* of M , denoted $\tau(M)$, as follows:

- (i) $\tau(M) = 0$ if $n \neq 4k$ for some integer k ;
- (ii) if $n = 4k$, let $\tau(M)$ be the signature of the nonsingular symmetric bilinear form

$$\Phi: H^{2k}(M; \mathbb{R}) \times H^{2k}(M; \mathbb{R}) \rightarrow \mathbb{R}.$$

EXERCISE 13. Let M be a closed, connected oriented $4k$ -manifold. Define a bilinear form

$$\Psi: H^*(M; \mathbb{R}) \times H^*(M; \mathbb{R}) \rightarrow \mathbb{R}$$

by

$$\Psi(x, y) = \langle (x \cup y)_{4k}, z_{\mathbb{R}} \rangle \in \mathbb{R},$$

where $(x \cup y)_{4k}$ is the $4k$ -dimensional component of $x \cup y$. Then show that the signature of Ψ is $\tau(M)$.

EXERCISE 14. Let M_1 and M_2 be disjoint, closed, connected oriented manifolds.

(a) Show that the manifold $M_1 \times M_2$ may be oriented in such a way that

$$\tau(M_1 \times M_2) = \tau(M_1) \cdot \tau(M_2).$$

(b) If M_1 and M_2 have the same dimension, show that

$$\tau(M_1 \cup M_2) = \tau(M_1) + \tau(M_2).$$

Note that a change in the orientation of a manifold merely changes the sign of its index. It is evident that the index of $\mathbb{C}P(2k)$ is ± 1 , depending on the choice of orientation. Thus, it follows from the above exercise that there exist $4k$ -dimensional manifolds of arbitrary index for all values of k .

The final question we would like to consider is the following: given a closed topological manifold M , when does there exist a compact manifold W with $M = \partial W$? Of course we must require that W be compact since M is always the boundary of $M \times [0, 1)$. Our first result gives a necessary condition for M to be such a boundary.

6.38 Theorem. *If W is a compact topological manifold with $\partial W = M$, then $\chi(M)$ is even.*

Proof. If the dimension of M is odd, then $\chi(M) = 0$ by Corollary 6.37. Thus we assume that the dimension of M is even so that the dimension of W is odd. Now consider the manifold $W \times I$ (see Exercise 15), where $I = [0, 1]$. We have

$$\partial(W \times I) = M \times I \cup W \times \partial I = M \times I \cup W \times \{0\} \cup W \times \{1\}.$$

Define $U = \partial(W \times I) - W \times \{1\}$ and $V = \partial(W \times I) - W \times \{0\}$. Note that U and V are open subsets of $\partial(W \times I)$ and W , U , and V all have the same homotopy type, whereas $U \cap V$ has the homotopy type of M .

The Mayer-Vietoris sequence for U and V becomes

$$H_{i+1}(\partial(W \times I)) \xrightarrow{h_{i+1}} H_i(M) \xrightarrow{f_i} H_i(W) \oplus H_i(W) \xrightarrow{g_i} H_i(\partial(W \times I)),$$

where each group is finitely generated and zero in dimensions greater than the dimension of W .

From the exactness we see that

$$\begin{aligned} \text{rank}(H_i(M)) &= \text{rank}(\text{image } h_{i+1}) + \text{rank}(\text{image } f_i), \\ \text{rank}(H_i(W) \oplus H_i(W)) &= \text{rank}(\text{image } f_i) + \text{rank}(\text{image } g_i), \\ \text{rank}(H_i(\partial(W \times I))) &= \text{rank}(\text{image } g_i) + \text{rank}(\text{image } h_i). \end{aligned}$$

By multiple cancellations it follows that

$$\sum (-1)^i \text{rank}(H_i(M)) - \sum (-1)^i \text{rank}(H_i(W) \oplus H_i(W)) + \sum (-1)^i \text{rank}(H_i(\partial(W \times I))) = 0.$$

Since $\partial(W \times I)$ is an odd-dimensional, closed manifold, we have $\chi(\partial(W \times I)) = 0$ by Corollary 6.37. Therefore

$$\chi(M) = 2 \cdot \sum (-1)^i \text{rank } H_i(W) = 2 \cdot \chi(W). \quad \square$$

EXERCISE 15. Suppose M_1 and M_2 are topological manifolds. Then show that $M_1 \times M_2$ is a topological manifold with

$$\partial(M_1 \times M_2) = (\partial M_1) \times M_2 \cup M_1 \times (\partial M_2).$$

Note that as an immediate consequence of Theorem 6.38 we have many manifolds which are not boundaries of compact manifolds, for example, $\mathbb{R}P(2k)$ and $\mathbb{C}P(2k)$.

A necessary condition for a closed manifold M to bound a compact oriented manifold is that the index of M be zero. In order to prove this we will need the following:

6.39 Lemma. *Suppose Φ is a symmetric, nonsingular bilinear form on a vector space V of dimension $2n$, and $\{x_1, \dots, x_n\}$ is a linearly independent set in V such that $\Phi(\sum a_i x_i, \sum b_j x_j) = 0$ for any coefficients $a_1, \dots, a_n, b_1, \dots, b_n$. Then the signature of Φ is zero.*

Proof. In the decomposition described previously, it is evident that t must be zero since Φ is nonsingular. We must show that $r = s = n$. We will prove inductively that $r \geq n$; a similar argument establishes $s \geq n$, from which the conclusion follows.

For $n = 1$, there exists an element y_1 in V with $\Phi(x_1, y_1) \neq 0$. Then

$$\Phi(y_1 + ax_1, y_1 + ax_1) = \Phi(y_1, y_1) + 2a\Phi(x_1, y_1)$$

so by choosing

$$a = \frac{1 - \Phi(y_1, y_1)}{2\Phi(x_1, y_1)}$$

we have $\Phi(y_1 + ax_1, y_1 + ax_1) = 1$ and $r \geq 1 = n$.

Now suppose the assertion is true for vector spaces of dimension $2(n - 1)$. Define a homomorphism

$$\Theta: V \rightarrow \mathbb{R}^n$$

by $\Theta(z) = (\Phi(x_1, z), \dots, \Phi(x_n, z))$. If Θ is not an epimorphism, then the dimension of the kernel of Θ is $\geq n + 1$. On the other hand, we may extend the linearly independent set to a basis $\{x_1, \dots, x_n, \omega_1, \dots, \omega_n\}$ for V and define

$$\Theta': V \rightarrow \mathbb{R}^n$$

by $\Theta'(z) = (\Phi(\omega_1, z), \dots, \Phi(\omega_n, z))$. The dimension of the kernel of Θ' is $\geq n$; hence

$$\ker \Theta \cap \ker \Theta' \neq 0.$$

But this cannot happen since Φ is nonsingular, so Θ must be an epimorphism.

Let $y_1 \in \Theta^{-1}(1, 0, \dots, 0)$. As before, there exists a real number a with $\Phi(y_1 + ax_1, y_1 + ax_1) = 1$. Now define

$$\Psi: V \rightarrow \mathbb{R}^2$$

by $\Psi(z) = (\Phi(x_1, z), \Phi(y_1, z))$ and note that Ψ is an epimorphism. If V' is the kernel of Ψ , then the restriction of Φ to V' is a nonsingular form and $\{x_2, \dots, x_n\}$ is a linearly independent set in V' satisfying the hypothesis. Thus, by the inductive hypothesis there exist vectors q_2, \dots, q_n in V' with $\Phi(q_i, q_j) = \delta_{ij}$. The collection $y_1 + ax_1, q_2, \dots, q_n$ then shows that $r \geq n$. \square

6.40 Theorem. *If M is a compact oriented $(4n + 1)$ -manifold with boundary, then the index of ∂M is zero.*

Proof. Denote by Φ the symmetric nonsingular bilinear form on $H^{2n}(\partial M; \mathbb{R})$. We will show that the signature of Φ is zero by proving that the image of

$$j^*: H^{2n}(M; \mathbb{R}) \rightarrow H^{2n}(\partial M; \mathbb{R})$$

is a subspace of half the dimension of $H^{2n}(\partial M; \mathbb{R})$ on which Φ is identically zero, where $j: \partial M \rightarrow M$ is the inclusion.

Let $z_{\mathbb{R}} \in H_{4n+1}(M, \partial M; \mathbb{R})$ be a fundamental class and take $\Delta z_{\mathbb{R}} \in H_{4n}(\partial M; \mathbb{R})$ to be the fundamental class given by the image of $z_{\mathbb{R}}$ under the connecting homomorphism. If $j^*(\alpha)$ and $j^*(\beta)$ are two elements of $H^{2n}(\partial M; \mathbb{R})$ in the image of j^* , then

$$\begin{aligned} \Phi(j^*(\alpha), j^*(\beta)) &= \langle j^*(\alpha) \cup j^*(\beta), \Delta z_{\mathbb{R}} \rangle \\ &= \langle j^*(\alpha \cup \beta), \Delta z_{\mathbb{R}} \rangle \\ &= \langle \alpha \cup \beta, j_* \Delta z_{\mathbb{R}} \rangle \\ &= 0. \end{aligned}$$

So Φ is identically zero on the image of j^* .

Consider the commutative diagram

$$\begin{array}{ccc} H^{2n}(M; \mathbb{R}) & \xrightarrow{j^*} & H^{2n}(\partial M; \mathbb{R}) \\ \downarrow \cong D' & & \downarrow \cong D \\ H_{2n+1}(M, \partial M; \mathbb{R}) & \xrightarrow{\Delta} & H_{2n}(\partial M; \mathbb{R}) \end{array}$$

as in the proof of Theorem 6.25, where D and D' are Poincaré duality isomor-

phisms. Then since $D(j^*(x)) = \Delta(D'(x))$, it follows that the image of j^* is isomorphic to the image of Δ . Thus, the dimension of the image of j^* is the same as the dimension of the kernel of j_* .

On the other hand, since \mathbb{R} is a field, the universal coefficient theorem gives a commutative diagram

$$\begin{array}{ccc} H^{2n}(M; \mathbb{R}) & \xrightarrow{\cong} & \text{Hom}(H_{2n}(M; \mathbb{R}), \mathbb{R}) \\ \downarrow j^* & & \downarrow (j_*)^\# \\ H^{2n}(\partial M; \mathbb{R}) & \xrightarrow{\cong} & \text{Hom}(H_{2n}(\partial M; \mathbb{R}), \mathbb{R}) \end{array}$$

in which the horizontal maps are isomorphisms. Then it is easily checked that the dimension of the image of j^* is equal to the dimension of the image of j_* .

Putting these together we have

$$\begin{aligned} 2 \cdot \dim \text{im } j^* &= \dim \ker j_* + \dim \text{im } j_* \\ &= \dim H_{2n}(\partial M; \mathbb{R}) \\ &= \dim H^{2n}(\partial M; \mathbb{R}). \end{aligned}$$

Thus, the image of j^* is a subspace of $H^{2n}(\partial M; \mathbb{R})$ of half the dimension. It follows from Lemma 6.39 that the index of ∂M is zero. □

Note that Theorems 6.38 and 6.40 give certain necessary conditions for closed manifolds to be boundaries of compact manifolds of one dimension higher. These conditions are more closely related than may be readily apparent.

6.41 Proposition. *If M^n is a closed oriented manifold, then*

$$\tau(M) \equiv \chi(M) \pmod{2}.$$

Proof. This is clear if the dimension of M is odd since $\chi(M) = 0 = \tau(M)$. If $\dim M \equiv 2 \pmod{4}$, then by Corollary 6.36 $\chi(M)$ is even, hence congruent to $\tau(M) \pmod{2}$. If the dimension of M is $4k$, then $\chi(M) \equiv \dim H^{2k}(M; \mathbb{R}) \pmod{2}$. On the other hand, $\tau(M) = r - s$, where $r + s = \dim H^{2k}(M; \mathbb{R})$. Thus

$$\chi(M) - \tau(M) \equiv 2s \equiv 0 \pmod{2}. \quad \square$$

From considering such examples as S^{2n} or $\mathbb{C}P(n)$ it is apparent that the congruence in Proposition 6.41 cannot be replaced by equality.

“Index” invariants of this type for manifolds are very important in algebraic and differential topology. Of particular interest is their connection with analysis, which arises from the analytical interpretation of cohomology groups via the theory of Hodge and de Rham. Much significant progress has

been made in recent years in relating geometric invariants to such analytical invariants as the indices of differential operators.

The results of Theorems 6.38 and 6.40 introduce us to another area of considerable current interest. Let M^n be a closed, oriented manifold. M^n is said to *bound* if there exists a compact, oriented manifold W^{n+1} and an orientation-preserving homeomorphism of M^n onto ∂W^{n+1} . Note that it is essential to require W^{n+1} to be compact, as M^n will always bound $M^n \times [0, 1]$ if $[0, 1]$ is properly oriented.

Two closed, oriented n -manifolds M_1^n and M_2^n are *oriented cobordant*, $M_1^n \sim M_2^n$, if the manifold given by the disjoint union $M_1^n \cup -M_2^n$ bounds a compact $(n + 1)$ -manifold W^{n+1} , where $-M_2^n$ is the manifold given by reversing the orientation on M_2^n . The manifold W^{n+1} is called a *cobordism* between M_1^n and M_2^n .

This defines an equivalence relation on the class of closed oriented n -manifolds. To see this, note that $M^n \sim M^n$ because $M^n \cup -M^n$ is homeomorphic to the boundary of $M^n \times [0, 1]$ by an orientation-preserving homeomorphism. To establish transitivity we glue two cobordisms together (Figure 6.17). That is, if $\partial W^{n+1} = M_1^n \cup -M_2^n$ and $\partial V^{n+1} = M_2^n \cup -M_3^n$ then by identifying W^{n+1} and V^{n+1} along the common copy of M_2^n we get a compact oriented manifold with boundary oriented homeomorphic to $M_1^n \cup -M_3^n$.

Let $[M^n]$ be the equivalence class represented by M^n . Denote the set of equivalence classes by $\mathfrak{N}_n^{\text{STOP}}$. We define an additive operation in $\mathfrak{N}_n^{\text{STOP}}$ by setting $[M_1^n] + [M_2^n] = [M_1^n \cup M_2^n]$, the equivalence class of the disjoint union. This gives $\mathfrak{N}_n^{\text{STOP}}$ the structure of an abelian group in which $-[M^n] = [-M^n]$ and the additive identity is the equivalence class of those manifolds which bound. The graded group

$$\mathfrak{N}_*^{\text{STOP}} = \sum_{n=0}^{\infty} \mathfrak{N}_n^{\text{STOP}}$$

may be given the structure of a commutative graded ring by defining $[M_1^n] \cdot$

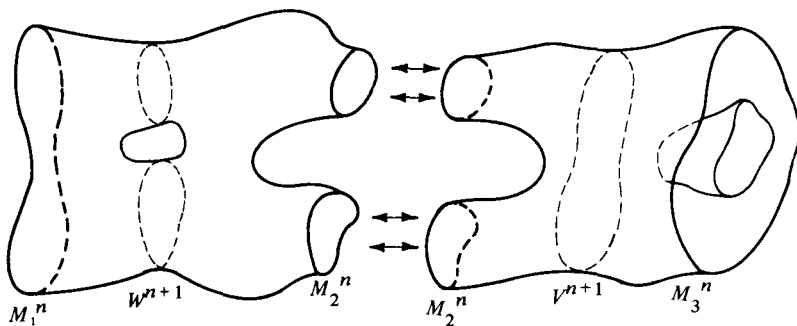

Figure 6.17

$[M_2^n] = [M_1^n \times M_2^n]$, the unit being the class of a positively oriented point in $\mathfrak{N}_0^{\text{STOP}}$. $\mathfrak{N}_*^{\text{STOP}}$ is the *oriented topological cobordism ring*.

If in the previous discussion we omit all references to orientation, there result the *unoriented* topological cobordism groups $\mathfrak{N}_n^{\text{TOP}}$. Denoting the unoriented equivalence class of the closed manifold M^n by $[M^n]_2$, it is apparent that $2 \cdot [M^n]_2 = 0$ since $M^n \cup M^n$ bounds $M^n \times [0, 1]$. Thus the *unoriented topological cobordism ring* $\mathfrak{N}_*^{\text{TOP}}$ becomes a Z_2 -algebra.

Define mappings $\Psi: \mathfrak{N}_*^{\text{STOP}} \rightarrow Z$ and $\Psi_2: \mathfrak{N}_*^{\text{TOP}} \rightarrow Z_2$ by $\Psi([M^n]) = \tau(M^n)$, the index of M^n , and $\Psi_2([M^n]_2) = \chi(M^n)$ reduced mod 2. By Theorems 6.38 and 6.40 these are well-defined functions of the respective cobordism classes. Furthermore, since both invariants are additive over disjoint unions and multiplicative over cartesian products, Ψ and Ψ_2 are ring homomorphisms.

A closed, oriented 0-manifold is a finite collection of points, each given a positive or negative orientation. It bounds if and only if the “algebraic” sum of the points is zero. Similarly an unoriented 0-manifold bounds if and only if it consists of an even number of points. Thus, $\Psi: \mathfrak{N}_0^{\text{STOP}} \rightarrow Z$ and $\Psi_2: \mathfrak{N}_0^{\text{TOP}} \rightarrow Z_2$ are both isomorphisms.

Note that since any closed 1-manifold is homeomorphic to a finite disjoint union of circles, it follows immediately that $\mathfrak{N}_1^{\text{TOP}} = 0 = \mathfrak{N}_1^{\text{STOP}}$.

EXERCISE 16. From the classification of closed 2-manifolds, compute $\mathfrak{N}_2^{\text{TOP}}$ and $\mathfrak{N}_2^{\text{STOP}}$.

It is evident that since each $\mathbb{R}P(2n)$ has Euler characteristic equal to one, $\Psi_2: \mathfrak{N}_{2n}^{\text{TOP}} \rightarrow Z_2$ is an epimorphism for each n . Similarly each $\mathbb{C}P(2n)$ has index ± 1 so that $\Psi: \mathfrak{N}_{4n}^{\text{STOP}} \rightarrow Z$ is an epimorphism for each n .

The structure of these rings has remained a mystery for some time. Recently the ring $\mathfrak{N}_*^{\text{TOP}}$ has been determined in all dimensions $\neq 4$ by Brumfiel *et al.* [1971], using results of Kirby and Siebenmann [1969]. As an excellent further reference in this area we recommend Stong [1968].

CHAPTER 7

Fixed-Point Theory

We are interested in studying the behavior of continuous functions on manifolds with particular interest in detecting the presence or absence of fixed points or coincidences. This is a classical problem, so it may prove enlightening to take a brief look at some of its early development.

During the 1880s, Poincaré studied vector distributions on surfaces. For an isolated singularity of such a distribution he assigned an *index* which was an integer (positive, negative, or zero). A vector distribution may be interpreted as a map of the surface to itself by translating a point via the vector based at that point. Here the fixed points of the map are the singularities of the distribution. Thus, summing the indices of the isolated singularities was the first step toward “algebraically” counting the fixed points of a map. Poincaré proved that if the surface is orientable of genus p and the distribution has only isolated singularities, then the sum of the indices is $2 - 2p$.

At the beginning of the twentieth century, Brouwer defined the *degree* of a mapping between n -manifolds. This allowed him to prove his fixed point theorem for mappings of D^n as well as to extend from 2 to n dimensions the definition of the index given by Poincaré. One of his important results was: if f and g are homotopic mappings of an n -manifold to itself and both f and g have only a finite number of fixed points, then the sum of the indices of the fixed points is the same for both functions. Since every mapping can be deformed into one with only a finite number of fixed points, this produces a homotopy invariant for the “algebraic” number of fixed points.

In 1923 Lefschetz published the first version of his fixed-point formula. Let M be a closed manifold and $f: M \rightarrow M$ be a map. Then for each k there is the induced homomorphism on homology with rational coefficients

$$f_k: H_k(M; \mathbb{Q}) \rightarrow H_k(M; \mathbb{Q}).$$

For each k we may choose a basis for the finite-dimensional, rational vector

space $H_k(M; \mathbb{Q})$ and write f_k as a matrix with respect to this basis. Denote by $\text{tr}(f_k)$ the trace of this matrix. If we define the *Lefschetz number* of f by

$$L(f) = \sum_{k=0}^{\infty} (-1)^k \text{tr}(f_k),$$

then $L(f)$ is independent of the choices involved and hence is a well-defined, rational-valued function of f . It is evident that $L(f)$ depends only on the homotopy class of f .

To see how this is connected with the earlier work of Brouwer, consider the case of a closed orientable manifold. Lefschetz proved the following: for each $\varepsilon > 0$ there is an ε -approximation g to f (here we are assuming a metric on the manifold) such that (i) g has only a finite number of fixed points, and (ii) for each fixed point x of g , g takes some neighborhood of x homeomorphically onto some other neighborhood of x . If x_1, \dots, x_m are the fixed points of g , denote by a_1, \dots, a_m the local degrees of g at these points in the sense of Brouwer. Then Lefschetz showed that

$$L(g) = \sum_{i=1}^m a_i.$$

Now for ε small, f and g are homotopic; hence, $f_* = g_*$ and we have

$$L(f) = \sum_{i=1}^m a_i.$$

This implies that $L(f)$ is always an integer and leads to the celebrated *Lefschetz fixed-point theorem*: if $L(f) \neq 0$, then f has a fixed point.

The idea of the proof is as follows: in the product space $M \times M$ consider the diagonal $\Delta(M)$ (Figure 7.1). Denote by $G(g)$ the graph of the function g . The points of $\Delta(M) \cap G(g)$ correspond to the fixed points of g . The previously

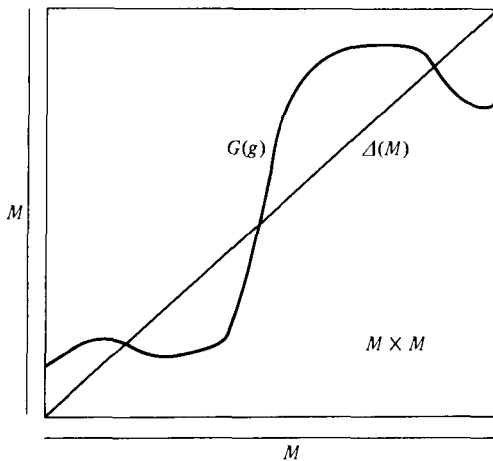

Figure 7.1

stated process of approximating f by g corresponds to making slight changes in $G(f)$ in order to put it into “general position” with respect to $\Delta(M)$. Here we see that the a_i have the proper interpretation, determined by that particular intersection of the graph with the diagonal. Considering $\Delta(M)$ and $G(g)$ as n -dimensional chains in $M \times M$, Lefschetz computed their intersection number and showed it to be the trace formula.

As a special case we may take f to be the identity map. Then $L(f) = \chi(M)$, the Euler characteristic of M . If M is a connected, differentiable manifold which admits a nonzero vector field, we may interpret this as before as a map homotopic to the identity but having no fixed points. Thus, $L(f) = 0$ and this implies $\chi(M) = 0$. The classical theorem of Hopf is the converse of this, that is, that if $\chi(M) = 0$ then M admits a nonzero vector field.

Generalizing the previous, if f and $g: M_1 \rightarrow M_2$ are maps between closed oriented n -manifolds, a *coincidence* of f and g is a point $x \in M_1$ such that $f(x) = g(x)$. Geometrically, if $G(f)$ and $G(g)$ are the graphs of the respective functions in $M_1 \times M_2$, their points of intersection correspond to the coincidences.

From the diagram

$$\begin{array}{ccc}
 H_q(M_1; \mathbb{Q}) & \xrightarrow{f_*} & H_q(M_2; \mathbb{Q}) \\
 \uparrow \mu \approx & & \uparrow \nu \approx \\
 H^{n-q}(M_1; \mathbb{Q}) & \xleftarrow{g^*} & H^{n-q}(M_2; \mathbb{Q})
 \end{array}$$

where the vertical homomorphisms are Poincaré duality isomorphisms, we define

$$\Theta_q: H_q(M_1; \mathbb{Q}) \rightarrow H_q(M_1; \mathbb{Q})$$

to be $\Theta_q = \mu g^* \nu^{-1} f_*$. Then the *coincidence number* of f and g is given by

$$L(f, g) = \sum_{q=0}^n (-1)^q \text{tr}(\Theta_q).$$

As before, $L(f, g)$ is the intersection number of $G(f)$ and $G(g)$, so if $L(f, g) \neq 0$, f and g have a coincidence. Note that if $M_1 = M_2$ and g is the identity, then $L(f, g) = L(f)$.

In this chapter we will prove these major results in the framework of the previous chapters. We will do this by first defining the coincidence index and the fixed-point index and establishing their basic properties. By introducing certain characteristic cohomology classes we establish the link between these indices and the corresponding coincidence numbers and Lefschetz numbers. In the process we encounter the Euler class and show that when evaluated on the fundamental class it yields the Euler characteristic. The principal tools used are the Poincaré duality theorem and the Thom isomorphism theorem. We close with some applications and observations.

It should be pointed out the spaces we consider, closed, oriented mani-

folds, could be made much more general. Similar techniques may be applied in the nonorientable case by using twisted coefficients. Many of the theorems are valid for such spaces as euclidean neighborhood retracts [Dold, 1965]. We impose these restrictions both for the purpose of continuity with the previous material and so that the reader may easily grasp the fundamental ideas involved. Many of the techniques of this chapter have been evolved from the excellent papers of Dold [1965] and Samelson [1965].

Let M_1 and M_2 be closed, connected, oriented n -manifolds with fundamental classes $z_i \in H_n(M_i)$, and corresponding Thom classes

$$U_i \in H^n(M_i \times M_i, M_i \times M_i - \Delta(M_i)), \quad i = 1, 2.$$

Suppose W is an open set in M_1 and

$$f, g: W \rightarrow M_2$$

are maps for which the coincidence set $C = \{x \in W | f(x) = g(x)\}$ is a compact subset of W .

By the normality of M_1 there exists an open set V in M_1 with $C \subseteq V \subseteq \bar{V} \subseteq W$. Define the *coincidence index* of the pair (f, g) on W to be the integer $I_{f,g}^W$ given by the image of the fundamental class z_1 under the composition

$$H_n(M_1) \rightarrow H_n(M_1, M_1 - V) \xrightarrow{\text{excision}} H_n(W, W - V) \xrightarrow{(f,g)_*} H_n(M_2 \times M_2, M_2 \times M_2 - \Delta(M_2)) \approx \mathbb{Z}.$$

Here the map $(f, g): W \rightarrow M_2 \times M_2$ is given by $(f, g)(x) = (f(x), g(x))$, and the identification

$$H_n(M_2 \times M_2, M_2 \times M_2 - \Delta(M_2)) \approx \mathbb{Z}$$

is given by sending a class α into the integer $\langle U_2, \alpha \rangle$. That this is an isomorphism follows from the fact in Equation (6.19) that for $p \in M_2$, $\langle U_2, I_{p,*}(s(p)) \rangle = 1$.

It must first be shown that this definition is independent of the choice of the open set V . Suppose V' is another open set with $C \subseteq V' \subseteq \bar{V}' \subseteq W$. Then consider the following diagram:

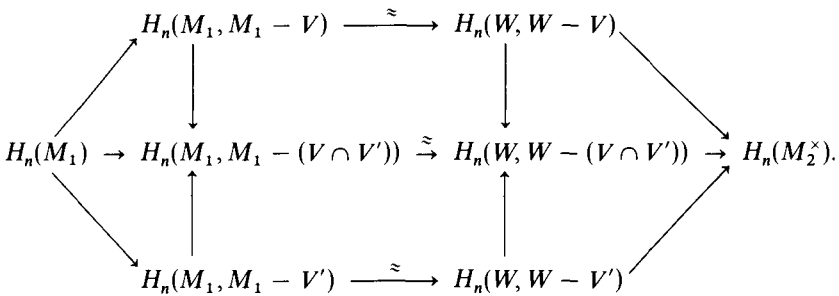

Here, as in Chapter 6, M_2^\times denotes the pair $(M_2 \times M_2, M_2 \times M_2 - \Delta(M_2))$. Since each triangle and rectangle commutes, the images of z_1 across the top

and across the bottom must be the same. This shows that $I_{f,g}^W$ is independent of the choice of V .

EXERCISE 1. Let W' be another open set in M_1 and f' and $g': W' \rightarrow M_2$ be maps such that $f = f'$ and $g = g'$ on $W \cap W'$ and

$$C' = \{x \in W' \mid f'(x) = g'(x)\}$$

is equal to C . Then show that

$$I_{f',g'}^{W'} = I_{f,g}^W.$$

This exercise tells us that the coincidence index is completely determined by the behavior of the functions around the coincidence set. In this sense it may be viewed as a local invariant. It is of particular interest then to see how the later results will amalgamate these local invariants into a global invariant.

Now suppose $W = W_1 \cup W_2 \cup \dots \cup W_k$ is a disjoint union of open sets and denote by C_i the compact set $C \cap W_i$ and by f_i and g_i the restrictions of f and g to W_i .

7.1 Lemma.

$$I_{f,g}^W = \sum_{i=1}^k I_{f_i,g_i}^{W_i}.$$

That is, the coincidence index is additive.

Proof. For each i choose an open set V_i such that $C_i \subseteq V_i \subseteq \bar{V}_i \subseteq W_i$ and set $V = \bigcup_{i=1}^k V_i$. Then the result follows from the commutativity of the following diagram:

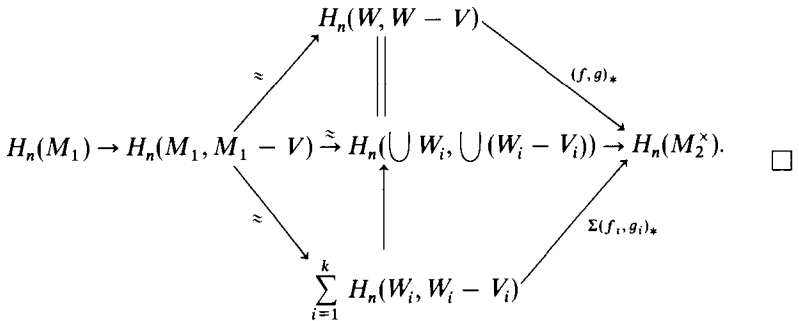

More generally, for any W let $C = C_1 \cup \dots \cup C_k$ be a decomposition of C into disjoint compact sets. Then by repeatedly using the normality of M_1 we can find a disjoint collect of open subsets of W , denoted W_1, \dots, W_k , such that $C_i \subseteq W_i$ for each i . Setting $W' = \bigcup W_i$ we can apply Lemma 7.1 and Exercise 1 to conclude that

$$I_{f,g}^W = \sum_{i=1}^k I_{f_i,g_i}^{W_i}.$$

7.2 Lemma. *If $C = \emptyset$, then $I_{f,g}^W = 0$.*

Proof. Suppose f and g have no coincidence points in the open set W . Then for any V , the map

$$(f, g): (W, W - V) \rightarrow (M_2 \times M_2, M_2 \times M_2 - \Delta(M_2))$$

can be factored through the pair $(M_2 \times M_2 - \Delta(M_2), M_2 \times M_2 - \Delta(M_2))$ so that the induced homomorphism $(f, g)_*$ must be zero. \square

7.3 Corollary. *If $I_{f,g}^W \neq 0$, then f and g have a coincidence in W .* \square

7.4 Lemma. *Suppose f_t and $g_t: W \rightarrow M_2, 0 \leq t \leq 1$, are homotopies and denote by*

$$C_t = \{x \in W \mid f_t(x) = g_t(x)\}$$

for $0 \leq t \leq 1$. If $D = \bigcup_t C_t$ is a compact subset of W , then

$$I_{f_0, g_0}^W = I_{f_1, g_1}^W.$$

Proof. Let V be an open set with $D \subseteq V \subseteq \bar{V} \subseteq W$. Then the maps

$$(f_t, g_t): (W, W - V) \rightarrow (M_2 \times M_2, M_2 \times M_2 - \Delta(M_2))$$

for $0 \leq t \leq 1$ give a homotopy of maps of pairs; hence

$$(f_0, g_0)_* = (f_1, g_1)_* \quad \text{and} \quad I_{f_0, g_0}^W = I_{f_1, g_1}^W. \quad \square$$

EXERCISE 2. Suppose M'_1 and M'_2 are closed, oriented m -manifolds and f' and $g': W' \rightarrow M'_2$ are maps, where W' is open in M'_1 . If

$$C' = \{y \in W' \mid f'(y) = g'(y)\}$$

is a compact subset of W' , show that the coincidence index $I_{f' \times f', g' \times g'}^{W' \times W'}$ is defined and is equal to $(I_{f', g'}^W) \cdot (I_{f', g'}^{W'})$.

As a special case of this construction we may take $M_1 = M_2$ (denoted by M) and $g = \text{identity}$ on the open set W . Here a coincidence of f and g is merely a fixed point of f . For this reason the coincidence index $I_{f, \text{id}}^W$ is denoted I_f^W and called the *fixed-point index* of f on W . For convenience we restate the previous results in terms of the fixed-point index.

7.5 Lemma. *If $f': W' \rightarrow M$ is a map from an open set W' in M such that $f = f'$ on $W \cap W'$ and the fixed-point sets of f and f' are the same compact subset of $W \cap W'$, then $I_f^W = I_{f'}^{W'}$.* \square

7.6 Lemma. *If $W = W_1 \cup W_2 \cup \dots \cup W_k$ is a disjoint union of open subsets of M , then*

$$I_f^W = \sum_{i=1}^k I_{f_i}^{W_i}. \quad \square$$

7.7 Lemma. *If $I_f^W \neq 0$, then f has a fixed point in W .* □

7.8 Lemma. *If $f_t: W \rightarrow M$ is a homotopy for which the set*

$$D = \{x \in W \mid f_t(x) = x \text{ for some } 0 \leq t \leq 1\}$$

is compact, then $I_{f_0}^W = I_{f_1}^W$. □

For most of the cases we will consider, the open set W will be the entire manifold M_1 . In this case we may choose the open set V to be M_1 so that the coincidence index becomes the image of the class z_1 under the homomorphism

$$(f, g)_*: H_n(M_1) \rightarrow H_n(M_2^x) \approx Z.$$

When this occurs, the coincidence index is denoted by $I_{f,g}$ and the fixed-point index by I_f .

EXAMPLE. Suppose M_1 and M_2 are closed, connected, oriented n -manifolds, $p \in M_2$, $f(M_1) = p$, and g has the property that

$$g_*: H_n(M_1) \rightarrow H_n(M_2)$$

is given by $g_*(z_1) = m \cdot z_2$. We want to determine the coincidence index $I_{f,g}$.

To do this consider the following diagram:

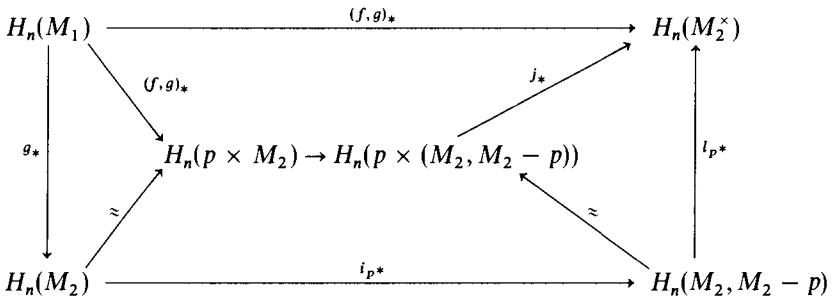

The definition of f allows us to factor $(f, g)_*$ through the upper rectangle. The commutativity of the other portions follows by using the natural identifications. Thus

$$\begin{aligned} I_{f,g} &= \langle U_2, (f, g)_*(z_1) \rangle = \langle U_2, l_{p*} i_{p*} g_*(z_1) \rangle = \langle U_2, l_{p*} i_{p*} (m \cdot z_2) \rangle \\ &= m \cdot \langle U_2, l_{p*} i_{p*} (z_2) \rangle = m \cdot \langle U_2, l_{p*} (s(p)) \rangle = m. \end{aligned}$$

In particular, if $M_1 = M_2$ and g is the identity, then $I_f = 1$.

As another example, suppose $M_1 = M_2 = M$ and $f: W \rightarrow M$ has a single fixed point $p \in W$. We want to give another interpretation of I_f^W for this case.

First, working in euclidean space, let D^n denote the closed unit disk in \mathbb{R}^n . Define a map

$$F: D^n \times D^n \rightarrow D^n$$

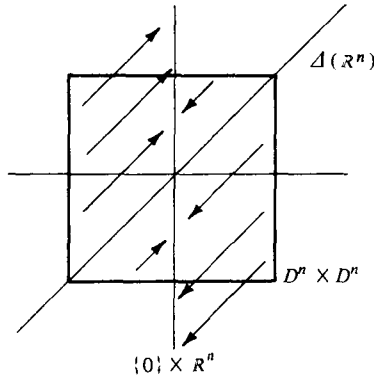

Figure 7.2

by $F(x, y) = \frac{1}{2}(y - x)$. This may be viewed geometrically in $\mathbb{R}^n \times \mathbb{R}^n$ as first taking the element of $\{0\} \times \mathbb{R}^n$ which is equivalent to (x, y) modulo the linear subspace $\Delta(\mathbb{R}^n)$ and then multiplying by $\frac{1}{2}$ (Figure 7.2).

Note that this map induces a homotopy equivalence of pairs

$$F: (D^n \times D^n, D^n \times D^n - \Delta(D^n)) \rightarrow (D^n, D^n - 0).$$

To see this define $j: D^n \rightarrow D^n \times D^n$ by $j(w) = (0, w)$. The homotopy $h_t: D^n \rightarrow D^n$ given by $h_t(w) = w/(1 + t)$ has $h_0(w) = w$, $h_1(w) = F \circ j(w)$, and $h_t(D^n - 0) \subseteq D^n - 0$ for $0 \leq t \leq 1$.

On the other hand, define

$$g_t: D^n \times D^n \rightarrow D^n \times D^n \quad \text{by } g_t(x, y) = \left(\frac{(1-t)x}{(1+t)}, \frac{y-tx}{1+t} \right).$$

It is easily checked that both coordinates lie in D^n . Then

$$g_0(x, y) = (x, y), \quad g_1(x, y) = (0, \frac{1}{2}(y - x)) = j \circ F(x, y)$$

and

$$g_t(D^n \times D^n - \Delta(D^n)) \subseteq D^n \times D^n - \Delta(D^n) \quad \text{for } 0 \leq t \leq 1.$$

Thus, j is a homotopy inverse for F .

Let Y be a closed, proper n -disk in M containing p such that the homeomorphism $h: Y \rightarrow D^n$ takes p into the origin. There exists an open, proper n -disk V in M such that $p \in V$, $\bar{V} \subseteq W \cap Y$ and $f(\bar{V}) \subseteq Y$. Denote by $k: \bar{V} \rightarrow D^n$ the homeomorphism and note that k restricts to a homeomorphism of the boundaries $k: \partial \bar{V} \rightarrow S^{n-1}$. We may assume that D^n is oriented and both k and h preserve orientations.

Define a map $\phi: S^{n-1} \rightarrow S^{n-1}$ by taking the following composition:

$$S^{n-1} \xrightarrow{k^{-1}} \partial \bar{V} \xrightarrow{f, \text{id}} Y \times Y - \Delta(Y) \xrightarrow{h \times h} D^n \times D^n - \Delta(D^n) \xrightarrow{F} D^n - 0 \xrightarrow{\pi} S^{n-1},$$

where the last map is given by projecting radially from the origin.

7.9 Proposition. *The degree of ϕ is I_f^W .*

Proof. As we have observed, the chosen generator for $H_{n-1}(S^{n-1})$ is given by the image of the fundamental class z of M under the composition

$$H_n(M) \rightarrow H_n(M, M - V) \approx H_n(\bar{V}, \partial\bar{V}) \xrightarrow{\partial} H_{n-1}(\partial\bar{V}) \xrightarrow{k_*} H_{n-1}(S^{n-1}).$$

Note that in computing the fixed-point index of f on W we may choose the open proper n -disk V . Consider the following commutative diagram:

$$\begin{array}{ccc} H_n(M) \rightarrow H_n(M, M - V) \xrightarrow{\cong} H_n(W, W - V) & \xrightarrow{(\mathcal{U}, i)_*} & H_n(M^\times) \approx Z \\ \uparrow \cong \text{incl}_* & & \uparrow \cong \text{incl}_* \\ H_n(\bar{V}, \partial\bar{V}) & \xrightarrow{(\mathcal{U}, i)_*} & H_n(Y \times Y, Y \times Y - \Delta(Y)) \\ \downarrow \partial & & \downarrow \cong (h \times h)_* \\ & & H_n(D^n \times D^n, D^n \times D^n - \Delta(D^n)) \\ & & \downarrow \cong F_* \\ & & H_n(D^n, D^n - 0) \\ & & \downarrow \cong \partial \\ H_{n-1}(S^{n-1}) & \xrightarrow{k_*^{-1}} H_{n-1}(\partial\bar{V}) & \xrightarrow{[F \circ (h \times h) \circ (\mathcal{U}, i)]_*} H_{n-1}(D^n - 0) \xrightarrow{\cong} H_{n-1}(S^{n-1}) \end{array}$$

Note that since the chosen generator of $H_n(M^\times)$, $l_{p^*}(s(p))$, arises from the orientation of the “vertical space” at $(p, p) \in \Delta(M)$ and the equivalence F collapses onto this vertical space, the vertical composition on the right takes $l_{p^*}(s(p))$ into the chosen generator for $H_{n-1}(S^{n-1})$. Now all of the vertical homomorphisms are isomorphisms, so if the composition across the top takes z into $m \cdot l_{p^*}(s(p))$, then ϕ must have degree m . \square

Note: As pointed out in the introduction, this is an important step: identifying the local degree of f at an isolated fixed point (degree of ϕ) with the local fixed-point index.

Having established these basic properties of the local index, we turn our attention to the corresponding global invariants. As before, we assume that M_1 and M_2 are closed connected oriented topological n -manifolds with fundamental classes z_1 and z_2 , respectively, and that f and $g: M_1 \rightarrow M_2$ are maps.

Using the coefficient homomorphism $Z \xrightarrow{\varepsilon} \mathbb{Q}$, we denote by \bar{z}_1 and \bar{z}_2 the images of z_1 and z_2 in rational homology. That is

$$\bar{z}_1 = \varepsilon_*(z_1) \in H_n(M_1; \mathbb{Q}) \quad \text{and} \quad \bar{z}_2 = \varepsilon_*(z_2) \in H_n(M_2; \mathbb{Q}).$$

Consider the following diagram of groups and homomorphisms:

$$\begin{array}{ccc}
 H_q(M_1; \mathbb{Q}) & \xrightarrow{f_*} & H_q(M_2; \mathbb{Q}) \\
 \uparrow \cong D_1 & & \uparrow \cong D_1 \\
 H^{n-q}(M_1; \mathbb{Q}) & \xleftarrow{g^*} & H^{n-q}(M_2; \mathbb{Q})
 \end{array}$$

where D_1 and D_2 are the Poincaré duality isomorphisms corresponding to \bar{z}_1 and \bar{z}_2 , respectively. For each q define

$$\Theta_q: H_q(M_1; \mathbb{Q}) \rightarrow H_q(M_1; \mathbb{Q})$$

by $\Theta_q = D_1 \circ g^* \circ D_2^{-1} \circ f_*$. Then the *Lefschetz number* or *coincidence number* of the pair (f, g) is defined to be the rational number

$$L(f, g) = \sum_q (-1)^q \text{tr } \Theta_q,$$

where $\text{tr } \Theta_q$ means the usual trace of Θ_q as a linear transformation from the finite-dimensional rational vector space $H_q(M_1; \mathbb{Q})$ to itself.

There is an alternate definition which will prove to be useful. For each q let

$$\hat{\Theta}_{n-q}: H^{n-q}(M_2; \mathbb{Q}) \rightarrow H^{n-q}(M_2; \mathbb{Q})$$

by given by

$$\hat{\Theta}_{n-q} = D_2^{-1} \circ f_* \circ D_1 \circ g^*.$$

Then we define

$$\hat{L}(f, g) = \sum_{r=1}^n (-1)^r \text{tr } \hat{\Theta}_r.$$

The relationship between these two definitions is given in the following exercises.

EXERCISE 3. Show that $\text{tr } \Theta_q = \text{tr } \hat{\Theta}_{n-q}$. Hence, conclude that

$$\hat{L}(f, g) = (-1)^n L(f, g).$$

EXERCISE 4. Show that $L(f, g) = (-1)^n L(g, f)$.

Recall that we have chosen a Thom class

$$U_2 \in H^n(M_2 \times M_2, M_2 \times M_2 - \Delta(M_2))$$

corresponding to the fundamental class z_2 in the manner of Chapter 6. From the composition

$$M_1 \xrightarrow{d} M_1 \times M_1 \xrightarrow{f \times g} M_2 \times M_2 \xrightarrow{i} (M_2 \times M_2, M_2 \times M_2 - \Delta(M_2))$$

we define the *Lefschetz class* or *coincidence class* of (f, g) to be

$$\mathcal{E}_{f,g} = d^* \circ (f \times g)^* \circ i^*(U_2) \in H^n(M_1).$$

Here d denotes the diagonal map. Note that the composition $(f \times g) \circ d$ is the map we have previously written as (f, g) . Let $\bar{\mathcal{E}}_{f,g}$ be the image of $\mathcal{E}_{f,g}$ in rational cohomology under the coefficient homomorphism.

We now want to establish a relationship between the Lefschetz number and the Lefschetz class of (f, g) . To do so we will first establish two lemmas.

Select a homogeneous basis $\{x_i\}$ for $H^*(M_2; \mathbb{Q})$ and denote by $\{a_i\}$ the basis for $H_*(M_2; \mathbb{Q})$ dual to $\{x_i\}$ under the Kronecker index. Define another basis $\{x'_i\}$ for $H^*(M_2; \mathbb{Q})$ by requiring that $D_2(x'_i) = a_i$ and let $\{a'_i\}$ be the basis for $H_*(M_2; \mathbb{Q})$ dual to $\{x'_i\}$ via the Kronecker index.

Using the duality isomorphism D_1 we may define similarly related bases $\{y_i\}$ and $\{y'_i\}$ for $H^*(M_1; \mathbb{Q})$ and $\{b_i\}$ and $\{b'_i\}$ for $H_*(M_1; \mathbb{Q})$.

Suppose now that

$$f^*(x_j) = \sum_l \beta_{jl} \cdot y_l \quad \text{and} \quad g^*(x'_i) = \sum_k \gamma_{ik} \cdot y'_k$$

for some rational coefficients β_{jl} and γ_{ik} .

7.10 Lemma. $\sum_i f_* \circ D_1 \circ g^*(x'_i) \times a'_i = \sum_i (f \times g)_*(b_i \times b'_i)$.

Proof. Expanding $g_*(b'_i)$ in terms of the basis $\{a'_k\}$ we have

$$g_*(b'_i) = \sum_k \lambda_{kj} \cdot a'_k$$

for some rational coefficients λ_{kj} . Then note that

$$\begin{aligned} \gamma_{ij} &= \left\langle \sum_k \gamma_{ik} y'_k, b'_j \right\rangle = \langle g^*(x'_i), b'_j \rangle \\ &= \langle x'_i, g_*(b'_j) \rangle = \left\langle x'_i, \sum_k \lambda_{kj} a'_k \right\rangle = \lambda_{ij}. \end{aligned}$$

Thus, $g_*(b'_j) = \sum_i \gamma_{ij} a'_i$, or, in other words, the coefficient of y'_k in $g^*(x'_i)$ is the same as the coefficient of a'_i in $g_*(b'_k)$.

Using the same approach, we can show that

$$f_*(b_i) = \sum_l \beta_{il} \cdot a_l.$$

To prove the lemma, we first expand $f_* \circ D_1 \circ g^*(x'_i)$ in terms of the basis $\{a_j\}$ and note that the coefficient of a_j is given by

$$\begin{aligned} \langle x_j, f_* \circ D_1 \circ g^*(x'_i) \rangle &= \langle f^*(x_j), D_1 \circ g^*(x'_i) \rangle \\ &= \left\langle \sum_l \beta_{jl} \cdot y_l, D_1 \left(\sum_k \gamma_{ik} \cdot y'_k \right) \right\rangle \\ &= \left\langle \sum_l \beta_{jl} \cdot y_l, \sum_k \gamma_{ik} b_k \right\rangle \\ &= \sum_k \beta_{jk} \cdot \gamma_{ik}. \end{aligned}$$

Thus

$$\begin{aligned}\sum_i f_* \circ D_1 \circ g^*(x'_i) \times a'_i &= \sum_i \left(\sum_j \left(\sum_k \beta_{jk} \cdot \gamma_{ik} \right) a_j \right) \times a'_i \\ &= \sum_{i,j,k} (\beta_{jk} \cdot \gamma_{ik}) (a_j \times a'_i).\end{aligned}$$

On the other hand,

$$\begin{aligned}\sum_i (f \times g)_*(b_i \times b'_i) &= \sum_i f_*(b_i) \times g_*(b'_i) \\ &= \sum_i \left(\sum_l \beta_{li} \cdot a_l \right) \times \left(\sum_k \gamma_{ki} a'_k \right) \\ &= \sum_{i,l,k} (\beta_{li} \cdot \gamma_{ki}) \cdot (a_l \times a'_k)\end{aligned}$$

and the conclusion follows. \square

7.11 Lemma. *If $d: M_1 \rightarrow M_1 \times M_1$ is the diagonal and $\bar{z}_1 \in H_n(M_1; \mathbb{Q})$ is the fundamental class, then*

$$d_*(\bar{z}_1) = \sum_i (-1)^{(\dim b_i)(\dim b'_i)} \cdot b_i \times b'_i.$$

Proof. This follows from the equations

$$\begin{aligned}&(-1)^{(\dim b'_j)(\dim b_k)} \cdot \langle y_k \times y'_j, d_*(\bar{z}_1) \rangle \\ &= (-1)^{(\dim y'_j)(\dim y_k)} \cdot \langle y_k \cup y'_j, \bar{z}_1 \rangle \\ &= \langle y'_j \cup y_k, \bar{z}_1 \rangle \\ &= \langle y_k, y'_j \cap \bar{z}_1 \rangle \\ &= \langle y_k, b_j \rangle \\ &= \delta_{k,j}.\end{aligned}$$

\square

7.12 Theorem. *The Lefschetz class $\bar{\mathcal{E}}_{f,g}$ and the Lefschetz number $L(f, g)$ of the pair (f, g) are related by the equation*

$$\langle \bar{\mathcal{E}}_{f,g}, \bar{z}_1 \rangle = L(f, g).$$

Proof. Since the $\{x'_i\}$ and $\{a'_i\}$ are dual bases under the Kronecker index, we may compute the Lefschetz number by

$$\begin{aligned}\hat{L}(f, g) &= \sum_r (-1)^r \operatorname{tr} \hat{\Theta}_r \\ &= \sum_r (-1)^{\dim x'_i} \langle \hat{\Theta}(x'_i), a'_i \rangle \\ &= \sum_r (-1)^{\dim x'_i} \langle D_2^{-1} \circ f_* \circ D_1 \circ g^*(x'_i), a'_i \rangle.\end{aligned}$$

By Equation (6.21) and the fact that $n - \dim x'_i = \dim x_i$, this is

$$\hat{L}(f, g) = \sum_i (-1)^{n(\dim x_i)(\dim x'_i)} \cdot \langle i^*(\bar{U}_2), f_* \circ D_1 \circ g^*(x'_i) \times a'_i \rangle$$

and by Lemma 7.10.

$$\hat{L}(f, g) = \sum_i (-1)^{n(\dim b_i)(\dim b'_i)} \cdot \langle i^*(\bar{U}_2), (f \times g)_*(b_i \times b'_i) \rangle.$$

[The sign change, while bothersome, works out nicely, since

$$\dim f_*(b_i) = \dim b_i, \quad \dim g_*(b'_i) = \dim b'_i$$

and the sum of the two dimensions in each case is always n .]

By Lemma 7.11

$$\begin{aligned} \hat{L}(f, g) &= (-1)^n \langle i^*(\bar{U}_2), (f \times g)_* d_*(\bar{z}_1) \rangle \\ &= (-1)^n \langle d^*(f \times g)^* i^*(\bar{U}_2), \bar{z}_1 \rangle \\ &= (-1)^n \langle \bar{\mathcal{E}}_{f, g}, \bar{z}_1 \rangle. \end{aligned}$$

Therefore, $L(f) = \langle \bar{\mathcal{E}}_{f, g}, \bar{z}_1 \rangle$. □

This relationship enables us to prove the following very important theorem:

7.13 Lefschetz Coincidence Theorem. *The coincidence index of the pair (f, g) on M_1 is equal to the Lefschetz number of (f, g) ; that is*

$$I_{f, g} = L(f, g).$$

Proof. Recall that the coincidence index is the integer given by

$$I_{f, g} = i_* \circ (f \times g)_* \circ d_*(z_1) \in H_n(M_2^{\times}) \approx \mathbb{Z},$$

where the isomorphism is given by sending a class α into the integer $\langle U_2, \alpha \rangle$.

Thus

$$\begin{aligned} I_{f, g} &= \langle U_2, i_*(f \times g)_* d_*(z_1) \rangle \\ &= \langle d^*(f \times g)^* i^*(U_2), z_1 \rangle \\ &= \langle \bar{\mathcal{E}}_{f, g}, z_1 \rangle \end{aligned}$$

and the image of this in the rationals is just

$$\langle \bar{\mathcal{E}}_{f, g}, \bar{z}_1 \rangle = L(f, g)$$

by Theorem 7.12. □

Note first that this may be viewed as an “integrality” theorem. That is, the Lefschetz number $L(f, g)$ is, by definition, a rational number in general. How-

ever, its identification with the coincidence index guarantees that it will be an integer.

7.14 Corollary. *If $f, g: M_1 \rightarrow M_2$ are maps between closed oriented manifolds for which $L(f, g) \neq 0$, then f and g have a coincidence.*

Proof. This follows immediately from the fact that

$$I_{f,g} = L(f, g) \neq 0$$

and applying Corollary 7.3. □

This is a convenient result, since in many cases the Lefschetz number is easier to compute than the coincidence index. Before proceeding with some applications, we examine a few special cases of the coincidence theorem.

First suppose $M_1 = M_2 = M$ and g is the identity map. As before the coincidence index $I_{f,\text{id}}$ is written I_f and called the fixed-point index. Similarly the Lefschetz number $L(f, \text{id})$ is written $L(f)$. For each k define

$$\Phi_k = f_*: H_k(M; \mathbb{Q}) \rightarrow H_k(M; \mathbb{Q}).$$

7.15 Lemma.

$$\sum_k (-1)^k \text{tr } \Phi_k = L(f).$$

Proof. Recall that

$$L(f) = L(f, \text{id}) = \sum_k (-1)^k \text{tr } \Theta_k,$$

where

$$\Theta_k = D \circ \text{id}^* \circ D^{-1} \circ f_* = f_*.$$

Thus, $\Phi_k = \Theta_k$ for each k , and the result follows. □

The Lefschetz class $\mathcal{E}_{f,\text{id}}$ is written \mathcal{E}_f and, as before, its image in rational cohomology will be denoted by $\bar{\mathcal{E}}_f$. With these definitions we have the following immediate consequences of the previous results.

7.16 Lefschetz Fixed-Point Theorem. *If $f: M \rightarrow M$ is a map of a closed, oriented n -manifold to itself, then $I_f = L(f)$. Thus, if $L(f) \neq 0$, then f has a fixed point.*

Proof. As in Theorem 7.13 we have

$$I_f = \langle \bar{\mathcal{E}}_f, \bar{z} \rangle = L(f).$$

Then the second conclusion follows from Lemma 7.7. □

In a further simplification we may take g and f both to be the identity on M . In this case the Lefschetz class is denoted by \mathcal{E}_M and called the *Euler class* of the oriented topological manifold M . The reason for this name is readily apparent since the Lefschetz number of the identity map is the Euler characteristic, that is

$$\begin{aligned} L(\text{identity}) &= \sum_k (-1)^k \text{tr}(\text{id}_k) \\ &= \sum_k (-1)^k \dim H^k(M; \mathbb{Q}) \\ &= \chi(M). \end{aligned}$$

Thus, as a special case of the coincidence theorem (Theorem 7.13) we have established the following:

7.17 Corollary. *The value of the Euler class of M on the fundamental class of M is equal to the Euler–Poincaré characteristic of M . That is*

$$\langle \mathcal{E}_M, z \rangle = \chi(M). \quad \square$$

Note that the definition of the Lefschetz number $L(f, g)$ is dependent only on the homotopy classes of the maps f and g . Thus, we can observe the following corollaries:

7.18 Corollary. *If $L(f, g) \neq 0$, g' is homotopic to g and f' is homotopic to f , then g' and f' have a coincidence.* \square

7.19 Corollary. *If $f: M \rightarrow M$ has $L(f) \neq 0$, then any map homotopic to f has a fixed point.* \square

7.20 Corollary. *If $\chi(M) \neq 0$, then any map $f: M \rightarrow M$ homotopic to the identity must have a fixed point.* \square

We now proceed with a number of applications of these theorems. First we give several fixed-point theorems due to Brouwer analogous to his theorem for the n -disk (Corollary 1.18), although slightly less well known.

7.21 Corollary. *If $f: S^n \rightarrow S^n$ is a map of degree $m \neq (-1)^{n+1}$, then f has a fixed point.*

Proof. If f has degree m , then the trace of $f_*: H_n(S^n; \mathbb{Q}) \rightarrow H_n(S^n; \mathbb{Q})$ must also be m . Since the trace of $f_*: H_0(S^n; \mathbb{Q}) \rightarrow H_0(S^n; \mathbb{Q})$ is 1, we have

$$\begin{aligned} L(f) &= \sum_i (-1)^i \text{tr} f_*^{(i)} \\ &= 1 + (-1)^n \cdot m. \end{aligned}$$

Now since $m \neq (-1)^{n+1}$ we have that $L(f) \neq 0$ and f must have a fixed point by Theorem 7.16. \square

Note that the antipodal map $A: S^n \rightarrow S^n$ does not have fixed points, but, as we saw in Corollary 1.22, the degree of A on S^n is $(-1)^{n+1}$.

7.22 Corollary. *If $f: \mathbb{R}P(2n + 1) \rightarrow \mathbb{R}P(2n + 1)$ is a map such that $f_*: H_{2n+1}(\mathbb{R}P(2n + 1); \mathbb{Q}) \rightarrow H_{2n+1}(\mathbb{R}P(2n + 1); \mathbb{Q})$ is multiplication by $m \neq 1$, then f has a fixed point.*

Proof. Note from the universal coefficient theorem that the rational homology groups of $\mathbb{R}P(2n + 1)$ are given by

$$H_k(\mathbb{R}P(2n + 1); \mathbb{Q}) \approx \begin{cases} \mathbb{Q} & \text{for } k = 0, 2n + 1 \\ 0 & \text{otherwise.} \end{cases}$$

Thus

$$\begin{aligned} L(f) &= \sum_i (-1)^i \text{tr } f_*^{(i)} \\ &= 1 + (-1)^{2n+1} \cdot m \\ &= 1 - m. \end{aligned}$$

So if $m \neq 1$, $L(f) \neq 0$ and f has a fixed point. \square

To see that the restriction in the theorem is necessary, consider the following function on $\mathbb{R}P(2n + 1)$. First write S^{2n+1} in complex coordinates as $S^{2n+1} = \{(z_1, \dots, z_{n+1}) \in \mathbb{C}^{n+1} \mid \sum |z_j|^2 = 1\}$. Let

$$\hat{g}: S^{2n+1} \rightarrow S^{2n+1}$$

be given by $\hat{g}(z_1, \dots, z_{n+1}) = (i \cdot z_1, \dots, i \cdot z_{n+1})$, where $i = \sqrt{-1}$. Note that $\hat{g} \circ \hat{g}$ is the antipodal map A and $\hat{g} \circ A = A \circ \hat{g}$. Thus, there is associated with \hat{g} a map $g: \mathbb{R}P(2n + 1) \rightarrow \mathbb{R}P(2n + 1)$ for which $g^2 = \text{identity}$.

If g has a fixed point, then there must be a nonzero $z_k = a + b \cdot i$ such that either $i \cdot z_k = z_k$ or $i \cdot z_k = -z_k$. But neither of these can happen, hence, g does not have a fixed point.

Note that $\mathbb{R}P(2n + 1)$ is a closed orientable manifold having the same rational homology groups as a sphere of the corresponding dimension. Such manifolds are called *rational homology spheres*. It is evident that corollaries of the type of Corollaries 7.21 and 7.22 will hold for any rational homology spheres.

7.23 Corollary. *If $f: \mathbb{C}P(n) \rightarrow \mathbb{C}P(n)$ is a map for which either*

- (1) n is even, or
- (2) $f_*: H^2(\mathbb{C}P(n)) \rightarrow H^2(\mathbb{C}P(n))$

is multiplication by $m \neq (-1)$, then f has a fixed point.

Proof. Recall that

$$H^*(\mathbb{C}P(n); \mathbb{Q}) \approx \mathbb{Q}[t]/t^{n+1},$$

where $t \in H^2(\mathbb{C}P(n); \mathbb{Q})$ is the image of an integral generator under the coefficient homomorphism. Thus, the trace of

$$f^*: H^{2k}(\mathbb{C}P(n); \mathbb{Q}) \rightarrow H^{2k}(\mathbb{C}P(n); \mathbb{Q})$$

is m^k for $0 \leq k \leq n$. This implies that the trace of

$$f_*^{(2k)}: H_{2k}(\mathbb{C}P(n); \mathbb{Q}) \rightarrow H_{2k}(\mathbb{C}P(n); \mathbb{Q})$$

is also m^k for $0 \leq k \leq n$. So we have

$$\begin{aligned} L(f) &= \sum_i (-1)^i \operatorname{tr} f_*^{(i)} \\ &= 1 + m + m^2 + \cdots + m^n \\ &= \begin{cases} \frac{1 - m^{n+1}}{1 - m} & \text{if } m \neq 1 \\ n + 1 & \text{if } m = 1. \end{cases} \end{aligned}$$

Note that if $n + 1$ is odd, this number must be nonzero. On the other hand, if $n + 1$ is even, it can only be zero when $m = -1$. Therefore, under the hypotheses of the corollary, $L(f) \neq 0$ and f has a fixed point. \square

Note that for $n = 1$, the antipodal map on $\mathbb{C}P(1) = S^2$ has no fixed points. Here, of course, $m = -1$.

EXERCISE 5. For a general odd integer n , define a map $f: \mathbb{C}P(n) \rightarrow \mathbb{C}P(n)$ that does not have fixed points.

In the same manner we may establish the following.

7.24 Corollary. *If $f: \mathbb{H}P(n) \rightarrow \mathbb{H}P(n)$ is a map for which either*

- (1) *n is even, or*
- (2) *$f^*: H^4(\mathbb{H}P(n)) \rightarrow H^4(\mathbb{H}P(n))$ is multiplication by $m \neq -1$,*

then f has a fixed point. \square

Let us now investigate the situation for maps of the torus

$$T^n = \underbrace{S^1 \times S^1 \times \cdots \times S^1}_{n\text{-fold}}$$

In this case it is necessary to change coefficients to an algebraically closed field, so let $i: \mathbb{Q} \rightarrow \mathbb{C}$ denote the inclusion of the rationals in the complex numbers. Using the coefficient homomorphism on homology and cohomol-

ogy, the previous theorems could easily be established using complex coefficients.

Recall that $H^*(T^n; \mathbb{C}) \approx E(\mathbb{C}; x_1, \dots, x_n)$, the exterior algebra over \mathbb{C} on n generators, all of dimension 1. Thus, $f^*: H^1(T^n; \mathbb{C}) \rightarrow H^1(T^n; \mathbb{C})$ is a linear transformation on an n -dimensional complex vector space. Since \mathbb{C} is algebraically closed, there exists a basis $\{y_1, \dots, y_n\}$ for $H^1(T^n; \mathbb{C})$ with respect to which the matrix $A = (a_{ij})$ of f^* is upper triangular. This basis retains the property that

$$H^*(T^n; \mathbb{C}) \approx E(\mathbb{C}; y_1, \dots, y_n).$$

In $H_1(T^n; \mathbb{C})$ denote by z_1, \dots, z_n the dual basis. Then

$$\begin{aligned} \langle y_k, f_*(z_i) \rangle &= \langle f^*(y_k), z_i \rangle \\ &= \left\langle \sum_j a_{ki} y_j, z_i \right\rangle \\ &= a_{ki}. \end{aligned}$$

Thus, $f_*(z_i) = \sum_k a_{ki} z_k$, and the trace of $f_*^{(1)}$ is given by $\sum_i a_{ii}$.

Denote by $z_i \wedge z_j$ the element of $H_2(T^n; \mathbb{C})$ dual to the product $y_i \wedge y_j$. Then $\{z_i \wedge z_j | i < j\}$ is a basis for $H_2(T^n; \mathbb{C})$ and

$$\begin{aligned} \langle y_i \wedge y_j, f_*(z_i \wedge z_j) \rangle &= \langle f^*(y_i \wedge y_j), z_i \wedge z_j \rangle \\ &= \langle f^*(y_i) \wedge f^*(y_j), z_i \wedge z_j \rangle \\ &= \left\langle \left(\sum_k a_{ik} y_k \right) \wedge \left(\sum_l a_{jl} y_l \right), z_i \wedge z_j \right\rangle \\ &= a_{ii} a_{jj} - a_{ij} a_{ji} = a_{ii} a_{jj}. \end{aligned}$$

The last equality follows from the fact that $i < j$; hence, $a_{ji} = 0$. Thus, the trace of $f_*^{(2)}$ is given by

$$\sum_{i < j} a_{ii} a_{jj}.$$

Similarly we find that for $1 \leq k \leq n$ the trace of $f_*^{(k)}$ is given by

$$\sum_{i_1 < \dots < i_k} a_{i_1 i_1} \cdots a_{i_k i_k}.$$

This implies that the Lefschetz number of f has the form

$$\begin{aligned} L(f) &= 1 - \sum_i a_{ii} + \sum_{i < j} a_{ii} a_{jj} - \dots + (-1)^n a_{11} a_{22} \cdots a_{nn} \\ &= (1 - a_{11})(1 - a_{22}) \cdots (1 - a_{nn}) \\ &= \det(I - A). \end{aligned}$$

Therefore, we have established the following result.

7.25 Corollary. *If $f: T^n \rightarrow T^n$ is a map for which $f^*: H^1(T^n) \rightarrow H^1(T^n)$ does not have $+1$ as an eigenvalue, then f has a fixed point. \square*

It is evident that many maps of the torus exist without fixed points. For example if $f_2: T^{n-1} \rightarrow T^{n-1}$ is any map and $f_1: S^1 \rightarrow S^1$ is a nontrivial rotation, then $f_1 \times f_2: T^n \rightarrow T^n$ has no fixed points.

EXERCISE 6. Let f and $g: S^n \rightarrow S^n$ be maps of degree m and k , respectively. Determine $L(f, g)$.

EXERCISE 7. (a) Let $f, g: S^{2n} \rightarrow \mathbb{C}P(n)$ be maps, $n > 1$. Show that $I_{f, g} = 0$.

(b) Do there exist maps $f, g: \mathbb{C}P(n) \rightarrow S^{2n}$ such that $I_{f, g} = m$ for any integer m ?

EXERCISE 8. Suppose that M is a closed, connected, oriented n -manifold with fundamental class $z \in H_n(M)$. If $f: M \rightarrow M$ is a map for which $f_*(z) = k \cdot z$ for some integer k , then show that

$$L(f, f) = k \cdot \chi(M).$$

The coincidence theorem gives an indirect, but appealing approach to the following basic result.

7.26 Fundamental Theorem of Algebra. *If $f(z) = z^n + a_{n-1}z^{n-1} + \dots + a_1z + a_0$ is a nonconstant, complex polynomial, then $f(z)$ has a root.*

Proof. Denoting by \mathbb{C} the complex numbers, we view f as a map from \mathbb{C} to \mathbb{C} . Note that $|f(z)| \rightarrow \infty$ as $|z| \rightarrow \infty$; hence, we may extend f to a map of the one-point compactification

$$f: S^2 \rightarrow S^2$$

by setting $f(\infty) = \infty$, where ∞ denotes the north pole.

Similarly the map $g: \mathbb{C} \rightarrow \mathbb{C}$ given by $g(z) \equiv 0$ may be extended to S^2 by setting $g(\infty) = 0$, 0 being identified with the south pole. Then a coincidence of f and g will be a root of the polynomial $f(z)$.

This situation corresponds to that of the example following Lemma 7.8, so that the coincidence number $L(f, g) = k$, where

$$f_*: H_2(S^2) \rightarrow H_2(S^2)$$

is multiplication by k .

Certainly, if there is any justice, the degree of f should be n . To prove this, define the contracting homeomorphism $r: \mathbb{C} \rightarrow D^2 - S^1$ by $r(z) = z/(1 + |z|)$. Note that $r^{-1}(w) = w/(1 - |w|)$. There is a uniquely defined map \hat{f} making the following diagram commute:

$$\begin{array}{ccc} \mathbb{C} & \xrightarrow{f} & \mathbb{C} \\ \downarrow r & & \downarrow r \\ D^2 - S^1 & \xrightarrow{\hat{f}} & D^2 - S^1 \end{array}$$

We want to extend \hat{f} to a map from D^2 to D^2 . So let $w_0 \in S^1$ and let w approach w_0 through values in the interior of D^2 :

$$\begin{aligned} \hat{f}(w) &= r(f(r^{-1}(w))) \\ &= r\left(f\left(\frac{w}{1-|w|}\right)\right) \\ &= \frac{f(w/(1-|w|))}{1+|f(w/(1-|w|))|} \\ &= \frac{w^n + a_{n-1}w^{n-1}(1-|w|) + \dots + a_0(1-|w|)^n}{(1-|w|)^n + |w^n + a_{n-1}w^{n-1}(1-|w|) + \dots + a_0(1-|w|)^n|} \end{aligned}$$

so that

$$\lim_{\substack{w \rightarrow w_0 \\ |w| < 1}} \hat{f}(w) = \frac{w_0^n}{|w_0^n|} = w_0^n.$$

This implies that we may extend \hat{f} to be defined on all of D^2 by setting $\hat{f}(w_0) = w_0^n$. Note that the mapping r^{-1} may be extended to a map $h: D^2 \rightarrow S^2$ by taking each point of S^1 into ∞ . Then from the diagram

$$\begin{array}{ccc} H_2(S^2, \infty) & \xrightarrow{f_*} & H_2(S^2, \infty) \\ \uparrow \approx h_* & & \uparrow \approx h_* \\ H_2(D^2, S^1) & \xrightarrow{\hat{f}_*} & H_2(D^2, S^1) \\ \downarrow \approx \partial & & \downarrow \approx \partial \\ H_1(S^1) & \xrightarrow{\hat{f}_*} & H_1(S^1) \end{array}$$

and the fact that on S^1 , $\hat{f}(e^{i\theta}) = e^{in\theta}$, we conclude that the degree of f must be n .

Therefore, $L(f, g) = n$ and f must have a root. □

EXERCISE 9. In the above setting, suppose that z_0 is a root of f of multiplicity k . Show that there exists an open set U about z_0 such that the local coincidence index $I_{f,g}^U$ is k .

The proof of Theorem 7.26 and, particularly, the accompanying exercise demonstrate that coincidence theory is a natural way to study problems of this type.

As another application of Theorem 7.16 we can prove the Poincaré–Hopf theorem on the sum of the indices of a vector field. For this purpose we must assume that our closed oriented manifold M^n is differentiable.

Let v be a smooth vector field on M^n such that the singularities (zeros) of v are isolated points of M^n . As observed before, we may associate with v a map

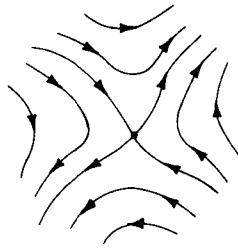

Figure 7.3

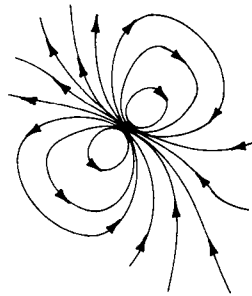

Figure 7.4

$f: M \rightarrow M$, homotopic to the identity, having as its fixed-point set the singularities of v . If x is an isolated singularity of v , one defines the *index* of v at x , i_x , as follows. Select a coordinate neighborhood U of x , homeomorphic to an open n -disk, which contains no other singularities of v . Within U choose an $(n - 1)$ -sphere about x . At each point of this sphere the associated vector of v must be nonzero. Transferring this into \mathbb{R}^n and normalizing the vectors defines a map from S^{n-1} to S^{n-1} . The degree of this map is i_x .

For example, on a two-dimension manifold a singularity of index -1 is shown in Figure 7.3, while the index in Figure 7.4 is $+2$. An excellent reference in this area is Milnor [1965].

It is intuitively clear that the index i_x is equal to the local degree of f at the fixed point x as defined prior to Proposition 7.9. We may use this fact to establish the following classical theorem.

7.27 Poincaré–Hopf Theorem. *If v is a smooth vector field with isolated singularities on the closed oriented differentiable manifold M^n , then the sum of the indices of v is the Euler characteristic of M ; that is*

$$\sum_x i_x = \chi(M).$$

Proof. From the observations above, the sum of the local indices of v is the same as the sum of the local degrees of f at its isolated fixed points. By Proposition 7.9 this is the sum of the local fixed-point indices of f . The additivity of the fixed-point index (Lemma 7.6), together with Theorem 7.16, implies that this sum is $L(f)$. But since f is homotopic to the identity, $L(f) = \chi(M)$. \square

Note: The theorem of Poincaré mentioned in the introduction to this chapter is a special case of Theorem 7.27. Specifically, a closed surface of genus p has Euler characteristic equal to $2 - 2p$; hence, this must also be the index sum.

Having strayed this far afield, we may consider one more connection with differential topology and geometry. On a smooth manifold M we may define a cochain complex using the differential forms of M and the exterior derivative. The homology groups of the complex are the *de Rham cohomology* groups of M , denoted $H^*(M, d)$. There is a natural transformation into cohomology with real coefficients

$$\Phi: H^*(M, d) \rightarrow H^*(M; \mathbb{R})$$

that may be described as follows. Suppose that M has been smoothly triangulated and ω is a smooth k -form on M . Then Φ associates with ω the function from the k -simplices of M into \mathbb{R} , whose value on a given simplex is the integral of ω over that simplex.

The famous *de Rham theorem* states that Φ is an isomorphism under which the exterior product in $H^*(M, d)$ corresponds to the cup product in $H^*(M; \mathbb{R})$. For a highly readable account of this, see Singer and Thorpe [1967].

Let M be a closed, connected, oriented, smooth 2-manifold endowed with a Riemannian metric. Then the *volume element* vol is a smooth 2-form on M and the *curvature* K is a smooth function associated with the Riemannian connection on M . The classical *Gauss–Bonnet theorem* then states that if the 2-form $K \cdot \text{vol}$ is integrated over the manifold M , the result is $2\pi \cdot \chi(M)$. In other words,

$$\frac{1}{2\pi} \int_M K \cdot \text{vol} = \chi(M).$$

The connection between these results and the previous is that integrating a 2-form over the manifold M corresponds under Φ with taking the Kronecker index with the fundamental class. It follows by Corollary 7.17 that the cohomology class represented by the 2-form $(1/2\pi)K \cdot \text{vol}$ is assigned by Φ to the Euler class \mathcal{E}_M of M .

As a final application let M be a closed, oriented n -manifold. A *flow* on M is a one-parameter group of homeomorphisms of M . Specifically, a flow is a function

$$\phi: \mathbb{R} \times M \rightarrow M$$

which is continuous and satisfies

- (i) $\phi(t_1 + t_2, x) = \phi(t_1, \phi(t_2, x))$,
- (ii) $\phi(0, x) = x$

for all $t_1, t_2 \in \mathbb{R}$ and $x \in M$.

Note that for each $t \in \mathbb{R}$ this defines a homeomorphism $\phi_t: M \rightarrow M$ by $\phi_t(x) = \phi(t, x)$ because $\phi_t^{-1} = \phi_{-t}$. A point $x_0 \in M$ is a *fixed point* of the flow if $\phi_t(x_0) = x_0$ for all $t \in \mathbb{R}$. Flows arise naturally on closed differentiable manifolds as the parameterized curves of a given vector field.

7.28 Theorem. *If M is a closed oriented manifold such that $\chi(M) \neq 0$, then any flow on M has a fixed point.*

Proof. For any $t_0 \in \mathbb{R}$ the homeomorphism

$$\phi_{t_0}: M \rightarrow M$$

is homotopic (actually isotopic) to the identity. So $L(\phi_{t_0}) = L(\text{identity}) = \chi(M) \neq 0$, and ϕ_{t_0} has a fixed point.

Now for each positive integer n denote by F_n the fixed-point set of $\phi_{1/2^n}$. It follows from the additivity of the parameter that F_n will be fixed by $\phi_{m/2^n}$ for any integer m . F_n is also compact since it is the inverse image of $\Delta(M)$ under the composition

$$M \xrightarrow{d} M \times M \xrightarrow{\phi_{1/2^n} \times \text{id}} M \times M.$$

For each positive integer n we have $F_{n+1} \subseteq F_n$ because

$$\phi_{1/2^{n+1}} \circ \phi_{1/2^{n+1}} = \phi_{1/2^n}.$$

Thus, $\{F_n\}$ is a nested family of nonempty, compact subsets of M which must have a nonempty intersection F .

This set F is fixed by ϕ_r for any dyadic rational r . Since these are dense in \mathbb{R} , the continuity of ϕ implies that each point of F must be a fixed point of the flow ϕ . □

EXERCISE 10. A flow on a manifold is the same as an *action* of the additive group of real numbers on the manifold. Using the techniques of this chapter, what results can you derive concerning actions of pathwise connected groups on closed oriented manifolds (for example, the additive group \mathbb{R}^n or the multiplicative group S^1)?

EXERCISE 11. Let f and g be maps from S^3 to S^2 . Show that if f is not homotopic to g , then f and g must have a coincidence.

It should be pointed out that although the fixed-point techniques we have developed can be very useful, they are still inadequate to solve many problems. As a specific example we cite the “last geometric theorem” of Poincaré.

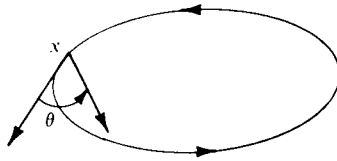

Figure 7.5

Suppose that we have an oval billiard table as in Figure 7.5, on which a single ball is rolling. Do periodic orbits with k bounces per period exist for every $k \geq 2$?

That the answer is yes was conjectured by Poincaré and proved by Birkhoff [1913].

If we orient the boundary curve, then the initial motion from the cushion is determined by the initial point x and the angle θ of projection measured from the forward pointing tangent (so $0 \leq \theta \leq \pi$). This set of initial motions given the product topology is an annulus $A = S^1 \times [0, \pi]$.

Now define

$$F: A \rightarrow A$$

by taking each initial motion onto that which follows the next bounce of the orbit. The conjecture may be stated by saying that F^k has a fixed point in the interior of A for all $k \geq 2$.

In solving the problem, the following theorem was proved: Any mapping $G: A \rightarrow A$ has two fixed points in the interior of A if

- (i) G is a homeomorphism leaving every point of the boundary circles fixed;
- (ii) the G image of a radial 1-cell wraps at least twice around the annulus;
- (iii) G preserves areas.

It is interesting to note that this problem could not have been solved by our techniques because the Lefschetz number in this case is zero.

In closing we consider briefly the question of the existence of a converse to the Lefschetz fixed-point theorem. For differentiable manifolds the Hopf theorem states that if $\chi(M) = 0$, then M admits a nonzero vector field, hence a map without fixed points which is homotopic to the identity. For topological manifolds there are a number of results by Brown and Fadell [1964], and others. As representatives of these results we state the following two theorems.

7.29 Theorem. *Let M be a compact, connected topological manifold. Then*

- (i) M admits maps close to the identity with a single fixed point;
- (ii) $\chi(M) = 0$ if and only if M admits maps close to the identity without fixed points. □

7.30 Theorem. *If M is a compact, simply connected topological manifold and $f: M \rightarrow M$ is a continuous map with $L(f) = 0$, then there exists a map g homotopic to f such that g is fixed-point free. \square*

For a deeper, more comprehensive study of fixed-point theory see Brown [1971].

Appendix I

The purpose of this appendix is to give a proof of Theorem 1.14. The proof requires the development of the subdivision operators on the chain groups. This fundamental technique is at the basis of essentially all of the computations and applications we will be able to make.

If $C \subseteq \mathbb{R}^n$ is a bounded set, then the *diameter* of C is given by $\text{diam } C = \text{lub}\{\|x - y\| \mid x, y \in C\}$. If $\mathcal{C} = \{C_i\}$ is a family of bounded subsets of \mathbb{R}^n , then $\text{mesh } \mathcal{C} = \text{lub}\{\text{diam } C_i\}$.

I.1 Proposition. *If s^n is an n -simplex with vertices a_0, a_1, \dots, a_n , then $\text{diam } s^n = \max\{\|a_i - a_j\| \mid i, j = 0, \dots, n\}$.*

Proof. Let $x = \sum t_i a_i$ and $y = \sum t'_i a_i$ be points in s^n . First fix x and allow y to vary. We want to show that

$$\text{lub}_{y \in s^n} \|x - y\| = \text{lub}_i \|x - a_i\|.$$

Now

$$\begin{aligned} \|x - y\| &= \|x - \sum t'_i a_i\| = \|\sum t'_i (x - a_i)\| \\ &\leq \sum |t'_i| \cdot \|x - a_i\| = \sum t'_i \|x - a_i\| \\ &\leq \sum t'_i \cdot \max\{\|x - a_i\|\} = \max\|x - a_i\|. \end{aligned}$$

Repeating the above, letting x vary gives

$$\|x - y\| \leq \max\|a_j - a_i\|. \quad \square$$

Let s^n be an n -simplex with vertices a_0, a_1, \dots, a_n . The *barycenter* $b(s^n)$ of s^n is the point in s^n given by

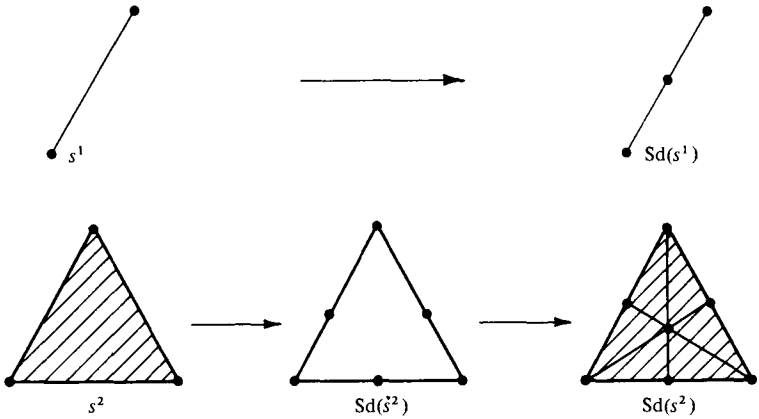

Figure I.1

$$b(s^n) = (1/(n + 1))(a_0 + \dots + a_n).$$

It is not difficult to show that for any i with $0 \leq i \leq n$, the points

$$\{b(s^n), a_0, \dots, a_{i-1}, a_{i+1}, \dots, a_n\}$$

span an n -simplex. We now define the *barycentric subdivision* $Sd(s^n)$ inductively on the dimension of the simplex. First set $Sd(s^0) = s^0$ for any zero simplex s^0 . Suppose now that Sd is defined on any simplex of dimension $(n - 1)$, so if t^{n-1} is any $(n - 1)$ -simplex, $Sd(t^{n-1})$ is a collection of $(n - 1)$ -simplices geometrically contained in t^{n-1} . Denote by \mathcal{s}^n the collection of all $(n - 1)$ -faces of s^n and define

$$Sd(\mathcal{s}^n) = \bigcup_{t^{n-1} \in \mathcal{s}^n} Sd(t^{n-1}).$$

Then $Sd(s^n)$ will consist of all n -simplices of the form $(b(s^n), t_0, \dots, t_{n-1})$, where (t_0, \dots, t_{n-1}) is an $(n - 1)$ -simplex in $Sd(\mathcal{s}^n)$ (Figure I.1).

I.2 Proposition. *If K is a collection of n -simplices, then*

$$\text{mesh } Sd(K) \leq (n/(n + 1)) \text{mesh } K.$$

Proof. Proceeding by induction on n , for $n = 0$ both sides are zero. So suppose the result is true for any collection of $(n - 1)$ -simplices. Let t^n be an n -simplex in $Sd(K)$. Then $t^n = (b(s^n), u_0, \dots, u_{n-1})$ where $s^n \in K$ and u_0, \dots, u_{n-1} are vertices of an $(n - 1)$ -simplex ω in $Sd(\mathcal{s}^n)$. Let s^{n-1} be the $(n - 1)$ -simplex in \mathcal{s}^n containing ω .

By Proposition I.1

$$\text{diam } t^n = \max \{ \|u_i - u_j\|, \|u_i - b(s^n)\| \}.$$

First consider the terms of the form $\|u_i - u_j\|$. We know that

$$\|u_i - u_j\| \leq \text{diam } \omega \leq ((n - 1)/n) \text{diam } s^{n-1}$$

by the inductive hypothesis. Now since $x/(x + 1)$ is an increasing function and the diameter of a subset is less than or equal to the diameter of the set, we have

$$\frac{n - 1}{n} \text{diam } s^{n-1} \leq \frac{n}{n + 1} \text{diam } s^n.$$

Hence, any term of the form $\|u_i - u_j\|$ is less than or equal to $(n/(n + 1)) \text{diam } s^n$.

For the terms $\|u_i - b(s^n)\|$ recall that if u'_0, \dots, u'_n are the vertices of s^n then $b(s^n) = (1/(n + 1)) \cdot \sum u'_i$. Each vertex u_i is a point in s^n so that $\|u_i - b(s^n)\| \leq \|u'_j - b(s^n)\|$ for some j by the proof of Proposition I.1. Then

$$\|u'_j - b(s^n)\| = \left\| u'_j - \frac{1}{n + 1} \sum_i u'_i \right\| = \left\| \sum_{i \neq j} \frac{u'_j - u'_i}{n + 1} \right\|,$$

where the sum now has n terms. But then

$$\begin{aligned} \left\| \sum_{i \neq j} \frac{u'_i - u'_j}{n + 1} \right\| &\leq \frac{1}{n + 1} \sum_{i \neq j} \|u'_j - u'_i\| \\ &\leq \frac{n}{n + 1} \max \|u'_j - u'_i\| \\ &\leq \frac{n}{n + 1} \text{diam } s^n. \end{aligned}$$

Thus, all terms will satisfy the desired inequality and the proof is complete. □

I.3 Corollary. *If K is a collection of n -simplices, let $\text{Sd}^m(K) = \text{Sd}(\text{Sd}^{m-1}(K))$ be the iterated barycentric subdivision. Then for an n -simplex s^n and any $\varepsilon > 0$ there exists a positive integer m such that*

$$\text{mesh } \text{Sd}^m(s^n) < \varepsilon.$$

Proof. This follows immediately from Proposition I.2 and the fact that

$$\lim_{m \rightarrow \infty} \left(\frac{n}{n + 1} \right)^m = 0. \quad \square$$

With these basic properties of the subdivision operator on simplices in mind, we now want to define an analogous operation on singular simplices. If C and C' are convex sets, a map $f: C \rightarrow C'$ is *affine* if given $x, y \in C$, $0 \leq t \leq 1$, then

$$f((1 - t)x + ty) = (1 - t)f(x) + tf(y).$$

It follows from this that if $x_0, \dots, x_p \in C$ and t_0, \dots, t_p are nonnegative with

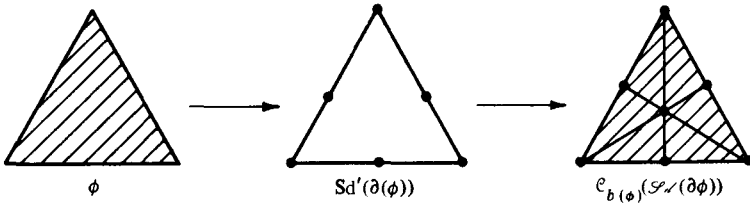

Figure I.2

$\sum t_i = 1$, then

$$f(\sum t_i x_i) = \sum t_i f(x_i).$$

If C is convex, define $A_n(C) \subseteq S_n(C)$ to be the subgroup generated by all affine singular n -simplices $\phi: \sigma_n \rightarrow C$. Denoting by v_0, v_1, \dots, v_n the vertices of σ_n , for any affine $\phi: \sigma_n \rightarrow C$ let $x_i = \phi(v_i)$. Then we can denote ϕ by $x_0 x_1 \cdots x_n$. In this notation it is evident that

$$\partial_i(x_0 x_1 \cdots x_n) = (x_0 \cdots x_{i-1} x_{i+1} \cdots x_n).$$

Thus, $\partial(A_n(C)) \subseteq A_{n-1}(C)$ and $\{A_n(C)\} = A_*(C)$ is a chain complex.

We now define a chain map $\mathcal{S}d': A_n(C) \rightarrow A_n(C)$ which is the algebraic analog of the subdivision operation. The definition is given inductively on the dimension n . For $n = 0$ let $\mathcal{S}d'$ be the identity. Suppose now that it is defined up through dimension $n - 1$, and let $\phi = x_0 x_1 \cdots x_n$ be an affine singular n -simplex in C . The *barycenter* of ϕ is the point

$$b(\phi) = \frac{x_0 + \cdots + x_n}{n + 1}.$$

For any point $b \in C$ define a homomorphism

$$\mathcal{C}_b: A_{n-1}(C) \rightarrow A_n(C)$$

by

$$\mathcal{C}_b(y_0 y_1 \cdots y_{n-1}) = (b y_0 y_1 \cdots y_{n-1}).$$

This is called the *cone* on b for obvious geometrical reasons. Finally, define for any affine singular n -simplex ϕ (see Figure I.2)

$$\mathcal{S}d'(\phi) = \mathcal{C}_{b(\phi)}(\mathcal{S}d'(\partial\phi)).$$

I.4 Proposition. $\partial \circ \mathcal{S}d' = \mathcal{S}d' \circ \partial$.

Proof. It is sufficient to check this on some affine singular n -simplex $\phi = x_0 x_1 \cdots x_n$. Let $b = b(\phi)$. Certainly the formula is true in dimension $n = 0$, so assume that it holds in dimension $(n - 1)$,

$$\partial \mathcal{S}d'(x_0 \cdots x_n) = \partial \mathcal{C}_b(\mathcal{S}d' \partial(x_0 \cdots x_n)).$$

We may split up the boundary on the right into those terms containing b and those not containing b ,

$$\partial \mathcal{S}d'(x_0 \cdots x_n) = \mathcal{S}d' \partial(x_0 \cdots x_n) - \mathcal{C}_b(\partial \mathcal{S}d' \partial(x_0 \cdots x_n)).$$

But the second term here must be zero, for by the inductive hypothesis

$$\partial \mathcal{S}d' \partial(x_0 \cdots x_n) = \mathcal{S}d' \partial \partial(x_0 \cdots x_n) = 0.$$

Therefore

$$\partial \mathcal{S}d' = \mathcal{S}d' \partial. \quad \square$$

Thus, $\mathcal{S}d': A_*(C) \rightarrow A_*(C)$ is a chain map of degree zero. Since the homology should not be affected by subdividing simplices, it is reasonable to expect that $\mathcal{S}d'$ is chain homotopic to the identity. To verify that this is indeed the case we must define a homomorphism

$$T': A_n(C) \rightarrow A_{n+1}(C)$$

such that

$$\partial T' + T' \partial = \mathcal{S}d' - 1.$$

We define T' inductively on n . Since for $n = 0$, $\mathcal{S}d'$ is the identity, we take T' to be zero. Now suppose T' is satisfactorily defined on all chains of dimension less than n and let ϕ be an affine singular n -simplex.

Note that

$$\begin{aligned} \partial(\mathcal{S}d' \phi - \phi - T' \partial \phi) &= [\partial \mathcal{S}d' - \partial - (\mathcal{S}d' - 1 - T' \partial)] \phi \\ &= 0 \quad \text{since } \mathcal{S}d' \partial = \partial \mathcal{S}d' \text{ and } \partial \partial = 0. \end{aligned}$$

Then set

$$T'(\phi) = \mathcal{C}_{b(\phi)}(\mathcal{S}d' \phi - \phi - T' \partial \phi).$$

To compute $\partial T'(\phi)$ we split it up into that part containing $b(\phi)$ and that part not containing $b(\phi)$. In other words,

$$\partial T'(\phi) = (\mathcal{S}d' \phi - \phi - T' \partial \phi) - \mathcal{C}_{b(\phi)} \partial(\mathcal{S}d' \phi - \phi - T' \partial \phi).$$

But from the above computation, the second term must be zero and T has the desired property.

If $f: C \rightarrow C'$ is an affine map between convex sets, then

$$f_*(A_n(C)) \subseteq A_n(C')$$

and f_* commutes with both $\mathcal{S}d'$ and T' .

We want to use the above homomorphisms to construct a degree-zero chain map

$$\mathcal{S}d: S_n(X) \rightarrow S_n(X)$$

for any space X , and show that it is chain homotopic to the identity.

Using the same technique as in the proof of Theorem 1.10, let $\psi: \sigma_n \rightarrow X$ be

a singular n -simplex. There is the induced homomorphism

$$\psi_{\#}: S_n(\sigma_n) \rightarrow S_n(X).$$

Now the element $\tau_n \in S_n(\sigma_n)$ given by the identity map is in $A_n(\sigma_n)$. So define

$$\mathcal{S}d(\psi) = \mathcal{S}d\psi_{\#}(\tau_n) = \psi_{\#}\mathcal{S}d'(\tau_n).$$

This just has the effect of subdividing the simplex by subdividing in its domain, which is convex. Similarly, set

$$T(\psi) = T\psi_{\#}(\tau_n) = \psi_{\#}T'(\tau_n).$$

1.5 Proposition. $\partial T + T\partial = \mathcal{S}d - 1$.

Proof. This follows immediately from the same properties of T' and $\mathcal{S}d'$. \square

We are now ready to give a proof of the theorem.

1.14. Theorem. *If \mathcal{U} is a family of subsets of X such that $\text{Int } \mathcal{U}$ covers X , then the chain map $i: S_{*}(X) \rightarrow S_{*}^{\mathcal{U}}(X)$ induces an isomorphism*

$$i_{*}: H_n(S_{*}^{\mathcal{U}}(X)) \rightarrow H_n(X).$$

Proof. We will construct a chain map $\Phi: S_{*}(X) \rightarrow S_{*}^{\mathcal{U}}(X)$ such that $\Phi \cdot i$ is the identity and $i \cdot \Phi$ is chain homotopic to the identity.

Let $\phi: \sigma_n \rightarrow X$ be a singular n -simplex. The family $\mathcal{V} = \{\phi^{-1}(U) \mid U \in \mathcal{U}\}$ has $\text{Int } \mathcal{V}$ covering σ_n . Since σ_n is compact, there exists a $\delta > 0$ such that if $C \subseteq \sigma_n$ and $\text{diam } C < \delta$, then C is contained in $\phi^{-1}(U)$ for some U .

By Corollary I.3 there exists an $m \geq 0$ with

$$\text{mesh } \text{Sd}^m \sigma_n < \delta.$$

This will imply that

$$\mathcal{S}d^m \phi \in S_n^{\mathcal{U}}(X).$$

Now for any singular simplex ϕ in X let $m(\phi)$ be the least integer for which

$$\mathcal{S}d^{m(\phi)} \phi \in S_n^{\mathcal{U}}(X).$$

Note that for $0 \leq i \leq n$, $m(\phi) \geq m(\partial_i \phi)$.

Recall that $\partial T + T\partial = \mathcal{S}d - 1$, so for any positive integer k we have

$$\partial T\mathcal{S}d^{k-1} + T\mathcal{S}d^{k-1}\partial = \mathcal{S}d^k - \mathcal{S}d^{k-1}.$$

Adding a sequence of these together gives

$$\partial T(1 + \cdots + \mathcal{S}d^{k-1}) + T(1 + \cdots + \mathcal{S}d^{k-1})\partial = \mathcal{S}d^k - 1.$$

So we define for any ϕ

$$\mathcal{F}(\phi) = T(1 + \mathcal{S}d + \cdots + \mathcal{S}d^{m(\phi)-1}),$$

and consider

$$\begin{aligned} (\partial \mathcal{T} + \mathcal{T} \partial) \phi &= \sum (-1)^i \partial_i T(1 + \cdots + \mathcal{S}d^{m(\phi)-1}) \phi \\ &\quad + \sum (-1)^i T(1 + \cdots + \mathcal{S}d^{m(\hat{c}_i, \phi)-1}) \partial_i \phi. \end{aligned}$$

By the above we have

$$\begin{aligned} (\partial \mathcal{T} + \mathcal{T} \partial) \phi &= \mathcal{S}d^{m(\phi)} \phi - \phi - T(1 + \cdots + \mathcal{S}d^{m(\phi)-1}) \partial \phi \\ &\quad + \sum (-1)^i T(1 + \cdots + \mathcal{S}d^{m(\hat{c}_i, \phi)-1}) \partial_i \phi \\ &= \mathcal{S}d^{m(\phi)} \phi - \phi - \sum_{i=0}^n (-1)^i T(\mathcal{S}d^{m(\hat{c}_i, \phi)} + \cdots + \mathcal{S}d^{m(\phi)-1}) \partial_i \phi. \end{aligned}$$

This leads us to define

$$\Phi(\phi) = \mathcal{S}d^{m(\phi)} \phi - \sum_{i=0}^n (-1)^i T(\mathcal{S}d^{m(\hat{c}_i, \phi)} + \cdots + \mathcal{S}d^{m(\phi)-1}) \partial_i \phi.$$

From looking at the summation we conclude that

$$\Phi(\phi) \in S_n^{\#}(X).$$

To consider $\Phi(\phi)$ as an element of $S_n(X)$ we apply the mapping i . The above manipulation shows that

$$\partial \mathcal{T} + \mathcal{T} \partial = i \circ \Phi - 1;$$

hence, $i \circ \Phi$ is chain homotopic to the identity. On the other hand, if $\phi \in S_n^{\#}(X)$, then $m(\phi) = 0$ and $\Phi \circ i$ is the identity. \square

Appendix II

The purpose of this appendix is to prove two of the basic theorems on topological manifolds which were used in Chapter 6. The first theorem states that any closed topological manifold may be imbedded in some euclidean space \mathbb{R}^n and that the imbedded manifold is a retract of a neighborhood in \mathbb{R}^n . The second theorem states that the boundary of a compact topological manifold admits a collaring.

The first result is an excellent example of a “folk” theorem, that is, a result which is well known and may be proved in a variety of ways, but which is difficult to locate in the literature or trace to its true origin. The imbedding technique we use is due to Dold, whereas the approach to the retraction property was suggested by Bing.

The second result is of more recent vintage. A collaring theorem for differentiable manifolds was proved by Milnor, and the analog for topological manifolds, by Brown [1962]. The proof we present here is due to Connelly [1971].

II.1 Theorem. *If M is a closed topological n -manifold, then M can be imbedded in euclidean space \mathbb{R}^k for some k .*

Proof. Let B_1, \dots, B_m be a collection of proper open n -balls in M which cover M . For $i = 1, \dots, m$ denote by

$$\bar{h}_i: B_i \rightarrow S^n - \{y\}$$

a homeomorphism onto the complement of the north pole. We can extend each \bar{h}_i to a map

$$h_i: M \rightarrow S^n$$

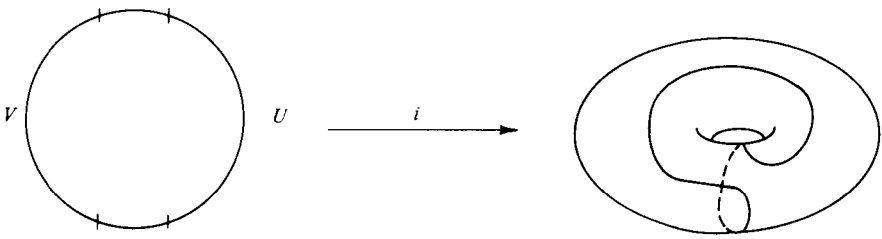

Figure II.1

by defining

$$h_i(x) = \begin{cases} \bar{h}_k(x) & \text{if } x \in B_i \\ \{y\} & \text{if } x \in M - B_i. \end{cases}$$

Now define the map

$$i: M \rightarrow S^n \times S^n \times \cdots \times S^n \subseteq \mathbb{R}^{n+1} \times \mathbb{R}^{n+1} \times \cdots \times \mathbb{R}^{n+1} = \mathbb{R}^{m(n+1)}$$

by $i(x) = (h_1(x), h_2(x), \dots, h_m(x))$. Then i gives the desired imbedding. □

Note: In general this is not a very economical way to imbed the manifold. That is, the dimension of the euclidean space is much higher than is generally necessary. For example, the covering of a circle by two proper 1-balls will produce the imbedding illustrated in Figure II.1 (actually in \mathbb{R}^4).

Suppose now that $i: M^n \rightarrow \mathbb{R}^k$ is an imbedding of a closed topological n -manifold. Denote by s a large k -simplex in \mathbb{R}^k containing M in its interior. We want to triangulate the complement of M in s in a particular way. Denote by Sd the barycentric subdivision operator defined in Appendix I and let $s_1 = Sd(s)$, a simplicial complex that is a finite union of k -simplices.

Now examine each closed k -simplex in s_1 . To those which intersect M we apply the operator Sd . Those which do not intersect M are left intact. The resulting simplicial complex is denoted s_2 .

By continuing this process, we produce a sequence of finite simplicial complexes $\{s_n\}$, each a finite union of closed k -simplices, with the property that s_m subdivides s_n whenever $m \geq n$ (Figure II.2).

II.2 Lemma. *This process defines a triangulation of $s - M$. In other words, for every point x of $s - M$ there is an integer m such that each k -simplex containing x in s_m remains intact in $s_{m'}$ for all $m' \geq m$.*

Proof. Let $x \in s - M$. Since M is compact, the distance from x to M is some positive number ϵ . By Corollary I.3 there is a positive integer m such that

$$\text{mesh } Sd^m(s) < \epsilon.$$

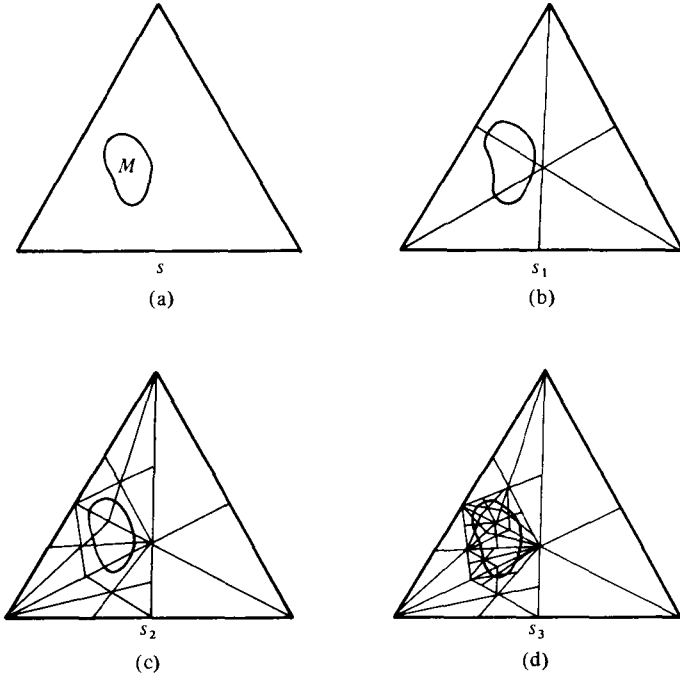

Figure II.2

There are two possibilities:

- (a) at some stage s_l , $l < m$, all of the closed k -simplices containing x were disjoint from M ; or
- (b) at each stage s_l , $l < m$, some closed k -simplex containing x intersected M .

In the first case, for all stages beyond s_l the triangulation around x remains unchanged. In the second case, each k -simplex of s_{m-1} that intersects M will be a k -simplex of $Sd^{m-1}(s)$. Thus, the k -simplices of s_m containing x will either be k -simplices of s_{m-1} that do not intersect M , or barycentric subdivisions of those that did, hence k -simplices of $Sd^m(s)$. In either situation it follows that the k -simplices of s_m that contain x will be disjoint from M .

Therefore, in each s_j , $j \geq m$, the triangulation about x remains constant. In this way we define the triangulation of $s - M$. \square

We now want to use this triangulation to define inductively a collection of subsets $N_0 \subseteq N_1 \subseteq \dots \subseteq N_k = N$ of s together with a map $r: N \rightarrow M$. Initially we take N_0 to be the union of M with all the vertices of $s - M$. If $y \in M$, define $r(y) = y$. If x_0 is a vertex of $s - M$, define $r(x_0)$ to be some point of M for which $\text{dist}(x_0, r(x_0)) = \text{dist}(x_0, M)$.

Suppose then that N_{i-1} and $r: N_{i-1} \rightarrow M$ have been defined. Let α be a

closed i -simplex in $s - M$; α will be contained in N_i if both of the following requirements are satisfied:

- (a) the boundary of α is contained in N_{i-1} ;
- (b) the map $r: \partial\alpha \rightarrow M$ can be extended continuously over α .

The space N_i will be the union of N_{i-1} together with all such closed i -simplices α . To define $r: N_i \rightarrow M$ it is sufficient to define r on each α so that it is compatible with the previous definition on the boundary. Let

$$A = \{ \delta \in \mathbb{R} \mid \text{there is a map } f: \alpha \rightarrow M, f|_{\partial\alpha} = r, \text{ and } \text{diam}(\text{image } f) = \delta \}$$

For α an i -simplex in N_i , A is a nonempty set that is bounded below. Let a be the greatest lower bound for A . Now define $r: \alpha \rightarrow M$ by choosing a map that extends the restriction of r to $\partial\alpha$ and satisfies $a \leq \text{diam}(r(\alpha)) \leq 2a$. Note that if $a = 0$, we may take r to be the constant map taking α into $r(\partial\alpha)$.

This completes the inductive step so that $N = N_k$ is a well-defined subset of s containing M and $r: N \rightarrow M$ is a function which is the identity on M . It remains to be shown that r is continuous and N is a neighborhood of M in \mathbb{R}^k . First we present some preliminary lemmas.

II.3 Lemma. *For any $\varepsilon > 0$ there exists a $\delta > 0$ such that if x is a point of $s - M$ and $\text{dist}(x, M) < \delta$, then the mesh of the set of k -simplices of $s - M$ containing x is less than ε .*

Proof. Let $\varepsilon > 0$; choose a positive integer m so that $(k/(k + 1))^m \cdot \text{diam}(s) < \varepsilon$. Define K_m to be the union of all closed k -simplices of s_m that do not intersect M . K_m is a compact subset of s .

Let $\delta = \text{dist}(M, K_m)$, or, if K_m is empty, take $\delta = 1$. Then if $\text{dist}(x, M) < \delta$, each closed k -simplex of s_m that contains x must intersect M . Thus, each of these simplices must lie in $\text{Sd}^m(s)$ and their mesh is less than or equal to $\text{mesh } \text{Sd}^m(s) \leq (k/(k + 1))^m \cdot \text{diam } s < \varepsilon$. The same inequality will obviously be true for the set of k -simplices of $s - M$ containing x . □

II.4 Lemma. *If \mathfrak{S} is a p -simplex, K is a convex set, and $f: \partial\mathfrak{S} \rightarrow K$ is a map, then f can be extended over all of \mathfrak{S} .*

Proof. Let $b(\mathfrak{S})$ be the barycenter of \mathfrak{S} and select a point $w \in K$. Every point x of \mathfrak{S} has a unique representation in the form $x = ty + (1 - t) \cdot b(\mathfrak{S})$, where y is a point of $\partial\mathfrak{S}$ and $0 \leq t \leq 1$. For each such point x define

$$f(x) = t \cdot f(y) + (1 - t)w.$$

This is well defined since K is convex; f is continuous and extends the original definition of f on $\partial\mathfrak{S}$. □

II.5 Corollary. *If \mathfrak{S} is a p -simplex and B is a proper n -ball in a topological manifold, then any map $f: \partial\mathfrak{S} \rightarrow B$ can be extended over all of \mathfrak{S} .*

Proof. Since B is a proper n -ball, there is a homeomorphism

$$h: B \rightarrow D^n - S^{n-1},$$

a convex subset of \mathbb{R}^n . We may compose f with h and apply Lemma II.4 to give the desired extension. \square

II.6 Theorem. *The function $r: N \rightarrow M$ defined previously is a continuous retraction of a neighborhood of M in \mathbb{R}^k onto M .*

Proof. From the construction of r it is apparent that r is continuous at each point of $s - M$. Thus, it is sufficient to check continuity at a point $y \in M$. So let $\varepsilon > 0$ and denote by $B(y, \varepsilon)$ the ball of radius ε about $y = r(y)$ in \mathbb{R}^k .

We construct inductively a collection of open sets V_0, V_1, \dots, V_{k+1} in \mathbb{R}^k about y . Let $V_0 = B(y, \varepsilon)$. For the inductive step, suppose that V_{l-1} has been defined. Let V_l be an open subset of V_{l-1} in \mathbb{R}^k containing y having the following properties:

- (i) $V_l \subseteq B(y, \delta_l)$, where $B(y, 5\delta_l) \subseteq V_{l-1}$;
- (ii) $V_l \cap M$ is a proper n -ball about y ;
- (iii) if $x \in V_l - M$, then the mesh of the set of k -simplices of $s - M$ containing x is $\leq \delta_l$.

That Requirement (iii) may be satisfied follows from Lemma II.3.

Now let $x \in V_{k+1}$, an open set about y . If $x \in M$, then

$$r(x) = x \in V_0 = B(y, \varepsilon).$$

So suppose $x \notin M$ and let \mathfrak{S} be a k -simplex of $s - M$ containing x .

By Requirements (iii) and (i) all of the vertices of \mathfrak{S} must lie in V_k and must be mapped by r into the proper n -ball $V_k \cap M$. By Corollary II.5 each 1-simplex α in \mathfrak{S} admits a map into $V_k \cap M$ extending the restriction of r to $\partial\alpha$. Thus, each set α is contained in N . Furthermore, since the diameter of the image of this extension is less than $2\delta_k$, the diameter of $r(\alpha)$ must be less than $4\delta_k$. The fact that $r(\alpha)$ intersects $V_k \cap M$, together with Requirement (i), implies that $r(\alpha) \subseteq V_{k-1} \cap M$.

Thus, the image of the 1-skeleton of \mathfrak{S} under r is contained in $V_{k-1} \cap M$, a proper n -ball. We may now apply the same argument to the 2-simplices of \mathfrak{S} . Continuing inductively, we find that the image of the k -skeleton of \mathfrak{S} under r , that is, $r(\mathfrak{S})$, is contained in $V_{k-k} = V_0 = B(y, \varepsilon)$. In particular $r(x) \in B(y, \varepsilon)$ and r is continuous at y .

To see that N is a neighborhood of M in \mathbb{R}^k , note that in the above argument, V_{k+1} is an open set about $y \in M$ on which r is completely defined. Hence, $V_{k+1} \subseteq N$ and y is an interior point of N . \square

EXERCISE 1. Make the necessary modifications in the preceding proofs to show that the results hold as well for compact manifolds with boundary.

EXERCISE 2. Prove a similar imbedding and retraction theorem for noncompact manifolds.

Finally, we turn to the collaring theorem for topological manifolds. As we stated previously, the proof given here is an intuitively appealing one due to Conelly [1971].

II.7 Theorem (Topological collaring theorem). *Let M^n be a compact topological manifold with boundary $\partial M = B$. Then there exists an open set U in M , containing B , and a homeomorphism*

$$h: U \rightarrow B \times [0, 1]$$

such that $h(x) = (x, 0)$ for all $x \in B$.

Proof. The idea of the proof is as follows. Since $B = \partial M$ we can find about each point of B an open set which looks like a portion of a “collar”; that is, B is locally collared in M . We attach a collar to the boundary of M and then use the local collaring to push the added collar into the manifold (or pull the manifold out over it), so that the added collar becomes the desired open set U .

By using the topological properties of euclidean half-space \mathbb{H}^n , we can show that for any point $x \in B = \partial M$ there is an open set U_x in B about x and an imbedding

$$h_x: \bar{U}_x \times [0, 1] \rightarrow M$$

such that for any $x' \in \bar{U}_x$, $h_x(x', 0) = x'$. Now B is a closed subspace of the compact manifold M ; hence, B is compact and there exist a finite number of open sets U_1, \dots, U_m in B and imbeddings

$$\bar{h}_i: \bar{U}_i \times [0, 1] \rightarrow M$$

such that

$$\bar{h}_i(x, 0) = x \quad \text{for all } x \text{ in } \bar{U}_i$$

and

$$B = \bigcup_i U_i.$$

Since B is compact Hausdorff, it is also normal; hence, there exist open sets V_1, \dots, V_m covering B such that $\bar{V}_i \subseteq U_i$ for each i .

Define M^+ to be the space formed from the union $M \cup (B \times [-1, 0])$ by identifying $x \in B \subseteq M$ with $(x, 0) \in B \times [-1, 0]$ (Figure II.3). For each i let

$$h_i: \bar{U}_i \times [-1, 1] \rightarrow M^+$$

be the function given by

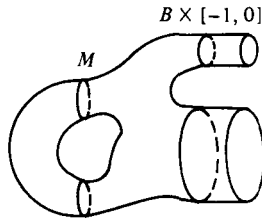

Figure II.3

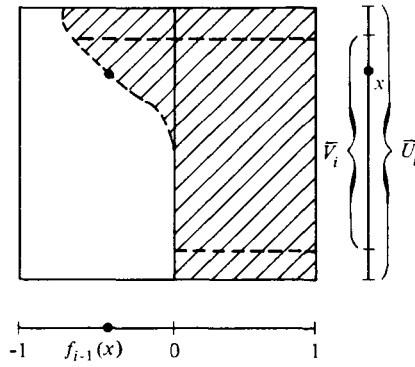

Figure II.4

$$h_t(x, t) = \begin{cases} \bar{h}_i(x, t) & \text{if } 0 \leq t \leq 1 \\ (x, t) & \text{if } -1 \leq t \leq 0. \end{cases}$$

Since these agree on the intersection, each h_i is a well-defined imbedding.

We now use these maps h_i to define inductively a family of imbeddings $g_i: M \rightarrow M^+$ and maps $f_i: B \rightarrow [-1, 0]$, $i = 0, 1, 2, \dots, m$, satisfying the following:

- (a) $g_i(M)$ contains $M \cup (\bigcup_{j \leq i} \bar{V}_j \times [-1, 0])$;
- (b) for any $x \in B$, $g_i(x) = (x, f_i(x))$;
- (c) $f_m(x) \equiv -1$;
- (d) for any $x \in B$, $\{x\} \times [f_i(x), 0] \subseteq g_i(M)$.

The imbeddings g_i correspond to the consecutive stages of pushing the collar into the manifold while the functions f_i keep track of the location of the boundary of M at each stage. It follows that g_m will be a homeomorphism of M with M^+ taking $x \in B$ to $(x, -1)$ in M^+ . This will give the desired collaring of B .

Define $g_0: M \rightarrow M^+$ to be the inclusion and set $f_0(B) \equiv 0$. Inductively, suppose g_{i-1} and f_{i-1} have been defined. Consider

$$h_i^{-1}(g_{i-1}(M)) \subseteq \bar{U}_i \times [-1, 1]$$

(for example, the shaded region in Figure II.4). We want to define an imbedding

$$\phi_i: h_i^{-1}(g_{i-1}(M)) \rightarrow \bar{U}_i \times [-1, 1]$$

by pushing to the left along the fibers until $\phi_i(h_i^{-1}(g_{i-1}(\bar{V}_i))) = \bar{V}_i \times \{-1\}$, but requiring that ϕ_i be the identity on $(\bar{U}_i - U_i) \times [-1, 1] \cup \bar{U}_i \times \{1\}$. Thus, ϕ_i represents a “pushing out” operation inside this local collar which will not affect the rest of the manifold.

To do this, we want a map $\lambda_i: \bar{U}_i \rightarrow [-1, 1]$ such that

$$\lambda_i(x) = \begin{cases} 2f_{i-1}(x) + 1 & \text{if } x \in \bar{V}_i \\ -1 & \text{if } x \in \bar{U}_i - U_i \end{cases}$$

and $\lambda_i(x) \leq 2f_{i-1}(x) + 1$ for all $x \in \bar{U}_i$.

Since \bar{V}_i and $\bar{U}_i - U_i$ are disjoint closed subsets of a normal space, we can find a map satisfying the stated condition on these two subspaces using the Tietze extension theorem. Taking the minimum of this map and $2f_{i-1}(x) + 1$ produces the desired map λ_i .

Now define ϕ_i by

$$\phi_i(x, t) = \begin{cases} (x, t) & \text{if } \lambda_i(x) \leq t \leq 1 \\ (x, 2t - \lambda_i(x)) & \text{if } f_{i-1}(x) \leq t \leq \lambda_i(x). \end{cases}$$

The behavior of the map ϕ_i may be described as taking each interval $\{x\} \times [\frac{1}{2}(\lambda_i(x) - 1), \lambda_i(x)]$ linearly onto $\{x\} \times [-1, \lambda_i(x)]$, recalling that $\frac{1}{2}(\lambda_i(x) - 1) \leq f_{i-1}(x)$ with equality holding on \bar{V}_i (Figure II.5).

We may now use ϕ_i to alter g_{i-1} to produce g_i . Specifically

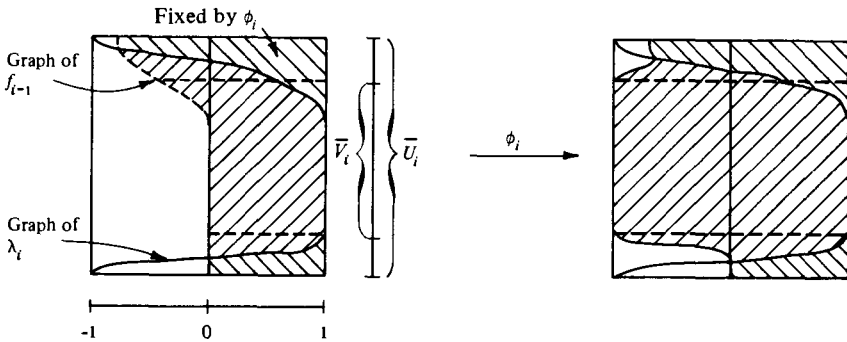

Figure II.5

$$g_i(x) = \begin{cases} (h_i \phi_i h_i^{-1}) g_{i-1}(x) & \text{if } x \in g_{i-1}(M) \cap h_i(\bar{U}_i \times [-1, 1]) \\ g_{i-1}(x) & \text{otherwise.} \end{cases}$$

Both g_i and g_i^{-1} are continuous. We define $f_i: B \rightarrow [-1, 0]$ by setting $f_i(x) = \pi(g_i(x))$ where π is the projection from $B \times [-1, 0]$ onto the second factor.

This completes the induction step and the homeomorphism g_m gives the required collaring of B . \square

References

- Adams, J.F. [1960]. On the nonexistence of elements of Hopf invariant one. *Ann. Math.* **72**, 20–104.
- Adams, J.F. [1962]. Vector fields on spheres. *Ann. Math.* **75**, 603–632.
- Adem, J. [1952]. The iteration of the Steenrod squares in algebraic topology. *Proc. Natl. Acad. Sci. U.S.A.* **38**, 720–726.
- Birkhoff, G.D. [1913]. Proof of Poincaré's geometric theorem. *Trans. Am. Math. Soc.* **14**, 14–22.
- Brown, M. [1962]. Locally flat embeddings of topological manifolds. In "Topology of 3-Manifolds and Related Topics" (M. K. Fort, Jr., ed.), pp. 83–91. Prentice-Hall, Englewood Cliffs, New Jersey.
- Brown, R. [1968]. "Elements of Modern Topology." McGraw-Hill, New York.
- Brown, R. [1988]. "Topology, 2nd ed." (Ellis Horwood Series: Mathematics and its Applications). Ellis Horwood, Ltd., Chichester.
- Brown, R.F. [1971]. "The Lefschetz Fixed Point Theorem." Scott, Foresman, Glenview, Illinois.
- Brown, R.F., and Fadell, E. [1964]. Non-singular path fields on compact topological manifolds. *Notices Am. Math. Soc.* **11**, 533.
- Brumfiel, G., Madsen, I., and Milgram, R. J. [1971]. PL characteristic classes and cobordism. *Bull. Am. Math. Soc.* **77**, 1025–1030.
- Connelly, R. [1971]. A new proof of Brown's collaring theorem. *Proc. Am. Math. Soc.* **27**, 180–182.
- Dold, A. [1965]. Fixed point index and fixed point theorem for Euclidean neighborhood retracts. *Topology* **4**, 1–8.
- Eckmann, B. [1943]. Gruppentheoretischer Beweis des Satzes von Hurwitz-Radon über die Komposition quadratischer Formen. *Comment. Math. Helv.* **15**, 358–366.
- Eilenberg, S., and Steenrod, N. [1952]. "Foundations of Algebraic Topology." Princeton Univ. Press, Princeton, New Jersey.
- Gray, B. [1975]. "Homotopy Theory: An Introduction to Algebraic Topology." (Pure and Applied Mathematics, **64**). Academic Press, New York.
- Hu, S.T. [1959]. "Homotopy Theory." Academic Press, New York.
- Kirby, R., and Siebenmann, L. [1969]. Foundations of TOPology. *Notices Am. Math. Soc.* **16**, 848.

- Lefschetz, S. [1926]. Intersections and transformations of complexes in manifolds. *Trans. Am. Math. Soc.* **29**, 429–462.
- Massey, W.S. [1967]. “Algebraic Topology: An Introduction.” Harcourt, New York.
- Massey, W.S. [1967], [1977]. “Algebraic Topology: An Introduction” (Graduate Texts in Mathematics, **56**). Springer-Verlag, New York—Heidelberg.
- Milnor, J.W. [1957]. Lectures on characteristic classes. Mimeographed notes, Princeton University, Princeton, New Jersey.
- Milnor, J.W. [1965]. “Topology from the Differentiable Viewpoint.” University of Virginia Press, Charlottesville, Virginia.
- Mosher, R.E., and Tangora, M. C. [1968]. “Cohomology Operations and Applications in Homotopy Theory.” Harper, New York.
- Samelson, H. [1965]. On Poincaré duality. *J. Anal. Math.* **14**, 323–336.
- Singer, I.M., and Thorpe, J. A. [1967]. “Lecture Notes on Elementary Topology and Geometry.” Scott, Foresman, Glenview, Illinois.
- Spanier, E.H. [1966]. “Algebraic Topology.” McGraw-Hill, New York.
- Steenrod, N., and Epstein, D. B. A. [1962]. “Cohomology Operations.” Princeton University Press, Princeton, New Jersey.
- Stong, R.E. [1968]. “Notes on Cobordism Theory.” Princeton University Press, Princeton, New Jersey.

Bibliography

Books and Historical Articles Since 1973

- Adams, J.F. (1972). "Algebraic Topology—A Student's Guide." (London Mathematical Society Lecture Note Series, 4.) Cambridge University Press, London.
- Adams, J.F. (1971). Algebraic topology in the last decade, In "Algebraic Topology," Proc. Sympos. Pure Math., vol. XXII, U. Wisconsin, Madison, 1970, pp. 1–22. Amer. Math. Soc., Providence, Rhode Island.
- Agoston, M.K. (1976). "Algebraic Topology: a First Course" (Monographs and Texts in Pure and Applied Math.), No. 32. Marcel Dekker, Inc., New York.
- Bott, R. (1985). On topology and other things. *Notices Amer. Math. Soc.* (2) **32**, 152–158.
- Browder, W. (1989). Commentary on topology, In "A Century of Mathematics in America, Part II," (Hist. Math.), Vol. 2, pp. 347–351. Amer. Math. Soc., Providence, Rhode Island.
- Brown, R. (1988). "Topology, 2nd ed." (Ellis Horwood Series: Mathematics and its Applications). Ellis Horwood, Ltd., Chichester.
- Croon, F.H. (1978). "Basic Concepts of Algebraic Topology" (Undergraduate Texts in Mathematics). Springer-Verlag, New York and Heidelberg.
- Dieudonné J. (1984). Emmy Noether and algebraic topology. *J. Pure Appl. Algebra* (1–3, 5–6) **31**.
- Dieudonné J. (1989). A History of Algebraic and Differential Topology 1900–1960." Birkhäuser Boston, Inc., Boston.
- Dold, A.A. (1972). "Lectures on Algebraic Topology" (Die Grundlehren der mathematischen Wissenschaften), Band 200. Springer-Verlag, New York and Berlin.
- Greenberg, M. J., and Harper, J. R. (1981). "Algebraic Topology, a First Course," (Mathematical Lecture Notes Series), Vol. 58. Benjamin/Cummings Publ. Co., Inc., Reading, Mass.
- Hilton, P. (1987). The birth of homological algebra. *Exposition Math.* (2) **5**, 137–142.
- Hilton, P. (1988). A brief, subjective history of homology and homotopy theory in this century. *Math. Mag.* (5) **61**, 282–291.

- James, I.M. (1984). "General Topology and Homotopy Theory." Springer-Verlag, New York and Berlin.
- James, I.M. (1990). Reminiscences of a topologist. *Math. Intelligencer* (1) **12**, 50–55.
- Johnson, D.M. (1987). "Brouwer's Coming of Age as a Topologist. Studies in the History of Mathematics" (MAA Studies in Math.), Vol. 26. Math. Assoc. Amer., Washington, D.C.
- Kosniowski, C. (1980). "A First Course in Algebraic Topology." Cambridge University Press, Cambridge and New York.
- Lefschetz, S. (1970). The early development of algebraic topology. *Bol. Soc. Brasil. Mat.* (1) **1**, 1–48.
- MacLane, S. (1978). Origins of the cohomology of groups. *Enseign. Math.* (2) **24**, 1-2, 1-29.
- Massey, W.S. (1977). "Algebraic Topology: an Introduction" (Graduate Texts in Mathematics), Vol. 56. Springer-Verlag, New York and Heidelberg. [A reprint of the 1967 original by Harcourt, Brace & World, New York].
- Massey, W.S. (1978). "Homology and Cohomology Theory" (Monographs and Textbooks in Pure and Applied Mathematics), Vol. 46. Marcel Dekker, Inc., New York.
- Massey, W.S. (1980). "Singular Homology Theory" (Graduate Texts in Mathematics), Vol. 70. Springer-Verlag, New York and Heidelberg.
- Maunder, C.R.F. (1980). "Algebraic Topology." Cambridge University Press, Cambridge and New York.
- May, J.P. (1990). Memorial address for J. Frank Adams. *Math. Intelligencer* (1) **12**, 40–44.
- May, J.P. (1990). Reminiscences on the life and mathematics of J. Frank Adams. *Math. Intelligencer* (1) **12**, 45–48.
- Munkres, J.R. (1984). "Elements of Algebraic Topology." Addison-Wesley, Menlo Park, California.
- Rotman, J.J. (1988). "An Introduction to Algebraic Topology" (Graduate Texts in Mathematics), Vol. 119. Springer-Verlag, New York and Berlin.
- Seifert, H., and Threlfall, W. (1980). "A Textbook of Topology." Academic Press, New York. [Translated by Michael Goldman from the 1934 German edition.]
- Switzer, R.M. (1975). "Algebraic Topology—Homotopy and Homology" (Die Grundlehren der mathematischen Wissenschaften), Band 212. Springer-Verlag, New York and Heidelberg.
- Toda, H. (1973). A survey of homotopy theory. *Advances in Math.* **10**, 417–455.
- Weil, A. (1979). Riemann, Betti, and the birth of topology. *Arch. Hist. Exact Sci.* (2) **20**, 91–96.
- Whitehead, G.W. (1983). Fifty years of homotopy theory. *Bull. Amer. Math. Soc* (NS) (1) **8**, 1–29.
- Whitney, H. (1988). Moscow 1935: Topology moving toward America. In "A Century of Mathematics in America, Part I" (Hist. Math), Vol. 1. Amer. Math. Soc., Providence, Rhode Island.

Books and Notes

- Abraham, R., and Robbin, J. (1967). "Transversal Mappings and Flows." Benjamin, New York.
- Adams, J.F. (1966). "Stable Homotopy Theory" (Lecture Notes in Mathematics), Vol. 3. Springer-Verlag, Berlin and New York.
- Aleksandrov, P.S. (1956). "Combinatorial Topology," Vols. 1–4. Graylock Press, Rochester, New York.

- Aleksandrov, P.S., and Hopf, H. (1965). "Topologie." Chelsea, New York.
- Arkowitz, M., and Curjel, C. R. (1967). "Groups of Homotopy Classes" (Lecture Notes in Mathematics), Vol. 4. Springer-Verlag, Berlin and New York.
- Artin, E., and Braun, H. (1969). "Introduction to Algebraic Topology." Merrill Publ., Columbus, Ohio.
- Atiyah, M.F. (1967). "K-Theory." Benjamin, New York.
- Auslander, L., and MacKenzie, R. E. (1963). "Introduction to Differentiable Manifolds." McGraw-Hill, New York.
- Berger, M., and Berger, M. (1968). "Perspectives in Nonlinearity. An Introduction to Nonlinear Analysis." Benjamin, New York.
- Bishop, R.L., and Crittenden, R.J. (1964). "Geometry of Manifolds." Academic Press, New York.
- Borel, A. (1964). "Cohomologie des espaces localement compacts d'après J. Leray" (Lecture Notes in Mathematics), Vol. 2. Springer-Verlag, Berlin and New York.
- Borel, A. (1967). "Topics in the Homology Theory of Fibre Bundles" (Lecture Notes in Mathematics), Vol. 36. Springer-Verlag, Berlin.
- Hocking, J.G., and Young, G.S. "Topology." Addison-Wesley, Reading, Massachusetts.
- Hu, S.-T. (1959). "Homotopy theory" (Pure and Appl. Mathematics), Vol. 8. Academic Press, New York.
- Hu, S.-T. (1965). "Theory of Retracts." Wayne State Univ. Press, Detroit, Michigan.
- Hu, S.-T. (1966). "Homology Theory: A First Course in Algebraic Topology." Holden-Day, San Francisco, California.
- Hu, S.-T. (1968). "Cohomology Theory." Markham Publ., Chicago, Illinois.
- Hu, S.-T. (1969). "Differentiable Manifolds." Holt, New York.
- Hudson, J.F.P. (1969). "Piecewise Linear Topology." Benjamin, New York.
- Hurewicz, W., and Wallman, H. (1941). "Dimension Theory." Princeton Univ. Press, Princeton, New Jersey.
- Husemoller, D. (1966). "Fibre Bundles." McGraw-Hill, New York.
- Husseini, S.Y. (1969). "The Topology of Classical Groups and Related Topics." Gordon & Breach, New York.
- "International Symposium on Algebraic Topology" (1958). Univ. Nacional Automata de México, México, D.F.
- Janich, K. (1968). "Differenzierbare G-Mannigfaltigkeiten" (Lecture Notes in Mathematics), Vol. 59. Springer-Verlag, Berlin and New York.
- Kamber, F., and Tondeur, P. (1968). "Flat Manifolds," (Lecture Notes in Mathematics), Vol. 67. Springer-Verlag, Berlin and New York.
- Kérékjártó, B. (1923). "Vorlesungen über Topologie" (Grundlehren der Math. Wissenschaften), Vol. 8. Springer-Verlag, Berlin and New York.
- Kultze, R. (1970). "Garbentheorie." Teubner, Stuttgart.
- Lamotke, K. (1968). "Semisimpliziale Algebraische Topologie" (Die Grundlehren der Mathematischen Wissenschaften), Vol. 147. Springer-Verlag, Berlin and New York.
- Lang, S. (1962). "Introduction to Differentiable Manifolds." Wiley (Interscience), New York.
- "Lectures given at Nordic Summer School in Mathematics" (1968). Math. Inst., Aarhus Univ., Aarhus.
- Lefschetz, S. (1930). "Topology" (Colloq. Publ.), Vol. 12. Am. Math. Soc. New York.
- Lefschetz, S. (1942). "Algebraic Topology" (Colloq. Publ.), Vol. 27. Am. Math. Soc., New York.
- Lefschetz, S. (1942). "Topics in Topology," Annals of Math. Stud., No. 10. Princeton Univ. Press, Princeton, New Jersey.
- Lefschetz, S. (1949). "Introduction to Topology." Princeton Univ. Press, Princeton, New Jersey.
- Maclane, S. "Homology." Academic Press, New York and Springer-Verlag, Berlin and New York.

- "Manifolds—Amsterdam 1970" (1971). (Lecture Notes in Mathematics), Vol. 197. Springer-Verlag, Berlin and New York.
- Massey, W.S. (1967). "Algebraic Topology: An Introduction." Harcourt, New York.
- May, J.P. (1967). "Simplicial Objects in Algebraic Topology." Van Nostrand-Reinhold, Princeton, New Jersey.
- Mayer, K.H. (1969). "Relationen zwischen charakteristischen Zahlen" (Lecture Notes in Mathematics), Vol. 111. Springer-Verlag, Berlin and New York.
- Milnor, J. (1957). Lectures on characteristic classes. Mimeographed notes, Princeton University, Princeton, New Jersey.
- Milnor, J. (1958). "Lectures on Differential Topology," mimeographed notes. Princeton Univ., Princeton, New Jersey.
- Milnor, J. (1963). "Morse Theory" (Annals of Mathematics Studies), No. 51. Princeton Univ. Press, Princeton, New Jersey.
- Milnor, J. (1965). "Lectures on the h -Cobordism Theorem" (notes by L. Siebenmann and J. Sondow). Princeton Univ., Princeton, New Jersey.
- Milnor, J. (1968). "Singular Points of Complex Hypersurfaces" (Annals of Mathematics Stud.), No. 61. Princeton Univ., Princeton, New Jersey.
- Morse, M., and Cairns, S. S. (1969). "Critical Point Theory in Global Analysis and Differential Geometry: An Introduction." Academic Press, New York.
- Munkres, J.R. (1966). "Elementary Differential Topology" (Annals of Mathematics Stud.), No. 54. Princeton Univ. Press, Princeton, New Jersey.
- Nagano, T. (1970). "Homotopy Invariants in Differential Geometry" (Memoires of Am. Math. Soc.), No. 100, Providence, Rhode Island.
- Narasimhan, M.S., Ramanan, S., Sridharan, R., and Varadarajan, K. (1964). "Algebraic Topology." Tata Inst. of Fundamental Res., Bombay.
- Nomizu, K. (1956). "Lie Groups and Differential Geometry." Math. Soc. of Japan, Tokyo.
- Northcott, D.G. (1960). "An Introduction to Homological Algebra." Cambridge Univ. Press, London and New York.
- Palais, R.S. (1968). "Foundations of Global Nonlinear Analysis." Benjamin, New York.
- Patterson, E.M. (1956). "Topology." Wiley (Interscience), New York.
- Poincaré, H. (1895). *Analysis Situs. J. École Poly. Paris* (2) 1, 1–123.
- Pontrjagin, L.S. (1959) Smooth manifolds and their applications in homotopy theory, *Am. Math. Soc. Transl., Ser. 2*, 11, 1–114.
- Porteous, I.R. (1969). "Topological Geometry." Van Nostrand Reinhold, Princeton, New York.
- Proc. Liverpool Singularities Symp. I, 1969/70* (1971). (Lecture Notes in Mathematics), Vol. 192. Springer-Verlag, Berlin and New York.
- Proc. Advan. Study Inst. Algebraic Topol.* (1970). Mat. Inst., Aarhus Univ., Aarhus.
- Proc. Conf. Algebraic Topol. Madison, 1970* (1971). *Proc. Symp. Pure Math.* 22. Am. Math. Soc., Providence, Rhode Island.
- Proc. Conf. Transformation Groups, New Orleans, 1967* (1968). Springer-Verlag, Berlin and New York.
- Quillen, D.G. (1967). "Homotopical Algebra" (Lecture Notes in Mathematics), Vol. 43. Springer-Verlag, Berlin and New York.
- "Reviews of Papers in Algebraic and Differential Topology, Topological Groups and Homological Algebra" (1968). Vols. I and II (compiled by N. Steenrod). Am. Math. Soc., Providence, Rhode Island.
- Seifert, H., and Threlfall, W. (1934). "Lehrbuch der Topologie." Teubner, Berlin.
- Séminaire Heidelberg-Strasbourg, 1966/67 (1969). "Dualité de Poincaré." Univ. de Strasbourg, Strasbourg.
- Séminaire Henri Cartan de l'École Normale Supérieure (publ. annually beginning in 1948–49). Secrétariat Mathématique, Paris.
- "Seminar on Combinatorial Topology" (1963). Inst. Hautes Études Sci., Paris.

- Sigrist, F. (ed.) (1971). "*H-Spaces-Neuchâtel (Suisse)*" (Lecture Notes in Mathematics), Vol. 196. Springer-Verlag, Berlin and New York.
- Singer, I.M., and Thorpe, J.A. (1961). "Lecture Notes on Elementary Topology and Geometry." Scott, Foresman, Glenview, Illinois.
- Spanier, E.H. (1966). "Algebraic Topology." McGraw-Hill, New York.
- Spivak, M. (1965). "Calculus on Manifolds." Benjamin, New York.
- Spivak, M. (1971). "Differential Geometry," Vols. I and II. Publish or Perish, Cambridge, Massachusetts.
- Stallings, J.R. (1967). "Lectures on Polyhedral Topology." Tata Inst. of Fundamental Res., Bombay.
- Stasheff, J. (1970). "*H-Spaces from the Homotopy Point of View*" (Lecture Notes in Mathematics), Vol. 161. Springer-Verlag, Berlin and New York.
- "The Steenrod Algebra and its Applications: A Conference to Celebrate N. Steenrod's Sixtieth Birthday" (1970). (F. Peterson, ed.) (Lecture Notes in Mathematics), Vol. 168. Springer-Verlag, Berlin and New York.
- Steenrod, N. (1951). "The Topology of Fibre Bundles." Princeton Univ. Press, Princeton, New Jersey.
- Steenrod, N.E., and Epstein, D. B. A. (1962). "Cohomology Operations" (Annals of Mathematics Studies), No. 50. Princeton Univ. Press, Princeton, New Jersey.
- Stong, R.E. (1968). "Notes on Cobordism Theory." Princeton Univ. Press, Princeton, New Jersey.
- Teleman, C. (1968). "Grundzüge der Topologie und Differenzierbare Mannigfaltigkeiten," (Mathematische Monographien), Vol. 8. VEB Deutscher Verlag der Wissenschaften, Berlin.
- Thomas, E. (1966). "Seminar on Fiber Spaces" (Lecture Notes in Mathematics), Vol. 13. Springer-Verlag, Berlin and New York.
- Toda, H. (1962). "Composition Methods in Homotopy Groups of Spheres" (Annals of Mathematics Studies), No. 49. Princeton Univ. Press, Princeton, New Jersey.
- tom Dieck, T., Kamps, K. H., and Puppe, D. (1970). "Homotopietheorie" (Lecture Notes in Mathematics), Vol. 157. Springer-Verlag, Berlin and New York.
- Tondeur, P. (1965). "Introduction to Lie Groups and Transformation Groups" (Lecture Notes in Mathematics), Vol. 7. Springer-Verlag, Berlin and New York.
- "Topology of Manifolds, Georgia—1969" (1970). Markham Publ., Chicago, Illinois.
- "Topology of 3-Manifolds and Related Topics, Georgia—1961" (1962). Prentice-Hall, Englewood Cliffs, New Jersey.
- "Topology Seminar, Wisconsin—1965" (1966). Ann. of Math. Studies, No. 60. Princeton Univ. Press, Princeton, New Jersey.
- Veblen, O. (1931). "Analysis Situs," Vol. 5. Am. Math. Soc. Colloq. Publ., New York.
- Wall, C.T.C. (1970). "Surgery on Compact Manifolds." Academic Press, London and New York.
- Wallace, A.H. (1970). "Algebraic Topology: Homology and Cohomology." Benjamin, New York.
- Wallace, A.H. (1957). "An Introduction to Algebraic Topology." Pergamon, Oxford.
- Wallace, A.H. (1968). "Differential Topology: First Steps." Benjamin, New York.
- Whitehead, G.W. (1966). "Homotopy Theory." MIT Press, Cambridge, Massachusetts.
- Whitney, H. (1957). "Geometric Integration Theory." Princeton Univ. Press, Princeton, New Jersey.
- Wilder, R.L. (ed.) (1941). "Lectures in Topology." Univ. of Michigan Press, Ann Arbor, Michigan.
- Wilder, R.L. (1963). "Topology of Manifolds." Vol. 32. Am. Math. Soc., Providence, Rhode Island.
- Wu, Wen-Tsün (1965). "A Theory of Imbedding, Immersion and Isotopy of Polytopes in Euclidean Space." Science Press, Peking.

Survey and Expository Articles

- Adams, J.F. (1968). A survey of homotopy theory. *Proc. Int. Congr. Math., Moscow, 1966* 33–43. Izdat. "Mir," Moscow.
- Adams, J.F. (1969). "Lectures on Generalized Cohomology" (Lecture Notes Mathematics), Vol. 99, pp. 1–138. Springer-Verlag, Berlin and New York.
- Adams, J.F. (1971). Algebraic topology in the last decade. *Proc. Symp. Pure Math.* **22** Am. Math. Soc., Providence, Rhode Island.
- Atiyah, M.F. (1963). The Grothendieck ring in geometry and topology. *Proc. Int. Congr. Math., Stockholm, 1962* 442–446. Inst. Mittag-Leffler, Djursholm.
- Atiyah, M.F. (1966). The role of algebraic topology in mathematics. *J. London Math. Soc.* **41**, 63–69.
- Atiyah, M.F. (1967). Algebraic topology and elliptic operators. *Commun. Pure Appl. Math.* **20**, 237–249.
- Atiyah, M.F. (1968). Global aspects of elliptic differential operators. *Proc. Int. Congr. Math., Moscow, 1966* 57–64. Izdat. "Mir," Moscow.
- Atiyah, M.F. (1969). Algebraic topology and operators in Hilbert space. *Lectures Modern Anal. Appl.* **1**, 101–121. Springer-Verlag, Berlin and New York.
- Atiyah, M.F. (1970). Vector fields on manifolds. "Arbeitsgemeinschaft für Forschung des Landes Nordrhein-Westfalen, Heft 200." Westdeutscher Verlag, Cologne.
- Atiyah, M.F., and Hirzebruch, F. (1961). Charakteristische Klassen und Anwendungen. *Enseignement Math. (2)* **7**; 188–213 (1962).
- Baum, P.F. (1970). Vector fields and Gauss-Bonnet. *Bull. Am. Math. Soc.* **76**, 1202–1211.
- Bing, R.H. (1967). Challenging conjectures. *Am. Math. Monthly* **74**, 56–64.
- Bognár, M. (1967). The origin and development of the theory of topological manifolds (in Hungarian) *Mat. Lapok* **18**, 37–57.
- Borsuk, K. (1958). Über einige Probleme der anschaulichen Topologie. *Jber. Deutsch. Math. Verein.* **60**, 101–114.
- Bott, R. (1961). Vector fields on spheres and allied problems. *Enseignement Math. (2)* **7**, 125–138 (1962).
- Bott, R. (1970). The periodicity theorem for the classical groups and some of its applications. *Ad. Math.* **4**, 353–411.
- Browder, W. (1968). Surgery and the theory of differentiable transformation groups. *Proc. Conf. Transformation Groups* 1–46. Springer-Verlag, Berlin and New York.
- Brown, E.H. (1969). The Arf invariant of a manifold. *Conf. Algebraic Topol., 1968* 9–18. Univ. of Illinois at Chicago Circle, Chicago, Illinois.
- Brown, R.F. (1971). Notes on Leray's index theory. *Adv. Math.* **7**, 1–28.
- Cairns, S.S. (1946). The triangulation problem and its role in analysis. *Bull. Am. Math. Soc.* **52**, 545–571.
- Calugareanu, G. (1970). Points de vue sur la théorie des noeuds. *Enseignement Math. (2)* **16**, 97–110.
- Cartan, H. (1968). L'oeuvre de Michael F. Atiyah. *Proc. Int. Congr. Math., Moscow 1966* 9–14. Izdat. "Mir," Moscow.
- Cartan, H. (1970). Les travaux de G. de Rham sur les variétés différentiables. "Essays on Topology and Related Topics," pp. 1–11. Springer-Verlag, Berlin and New York.
- Cartan, H. (1970). Structural stability of differential mappings. *Proc. Int. Conf. Functional Anal. Related Topics, Tokyo, 1969* 1–10. Univ. of Tokyo Press, Tokyo.
- Černavskii, A. V. (1963). Geometric topology of manifolds (in Russian). "Itogi Nauki" (Algebraic Topology, 1962), pp. 161–187. Akad. Nauk SSSR, Moscow.
- Chern, S.S. (1946). Some new viewpoints in differential geometry in the large. *Bull. Amer. Math. Soc.* **52**, 1–30.

- Chern, S.S. La géométrie des sous-variétés d'un espace euclidien a plusieurs dimensions. *Enseignement Math.* **40**, 26–46.
- Chern, S.S. (1966). The geometry of G -structures. *Bull. Am. Math. Soc.* **72**, 167–219.
- Chevalley, C., and Weil, A. (1957). Hermann Weyl (1885–1955). *Enseignement Math.* **3**, 157–187.
- Čisang, H., and Černavskii, A. V. (1967). Geometric topology of manifolds (in Russian). “Algebra, Topology, Geometry, 1965,” pp. 219–261. Akad. Nauk SSSR, Moscow.
- Cockcroft, W.H., and Jarvis, T. (1964). An introduction to homotopy theory and duality. I. *Bull. Soc. Math. Belg.* **16**, 407–428; II, **17** (1965), 3–26.
- Connell, E.H. (1970). Characteristic classes. *Illinois J. Math.* **14**, 496–521.
- de Rham, G. (1961). La théorie des formes différentielles extérieures et l'homologie des variétés différentiables. *Rend. Mat. Appl.* (5) **20**, 105–146.
- de Rham, G. (1965). Sur les invariants de torsion de Reidemeister-Franz, et de J. H. C. Whitehead. *Rev. Roumaine Math. Pure Appl.* **10**, 679–685.
- de Rham, G. (1967). Introduction aux polynômes d'un noeud. *Enseignement Math.* (2) **13**, 187–194. (1968).
- Dold, A. (1968). (Co-)homology properties of topological manifolds. *Conf. Topol. Manifolds* 47–57. Prindle, Weber, and Schmidt, Boston, Massachusetts.
- Dold, A. (1971). Chern classes in general cohomology. In “Symposia Mathematica,” Vol. 5. Academic Press, London and New York.
- Duke, R. A. (1970). Geometric embedding of complexes. *Am. Math. Monthly* **77**, 597–603.
- Eckmann, B. (1962). Homotopie und Homologie. *Enseignement Math.* (2) **8**, 209–217.
- Eckmann, B. (1971). Simple homotopy type and categories of fractions. *Symp. Math.* **5**, 285–299.
- Eilenberg, S. (1949). On the problems of topology. *Ann. Math.* **50**, 247–260.
- Eilenberg, S. (1963). Algebraic topology. “Lectures on Modern Mathematics,” Vol. I, pp. 98–114. Wiley, New York.
- Eisenack, G. (1969). Lefschetzche Fixpunkträume und Fixpunkte von iterierten Abbildungen.” Gesellschaft für Math. und Datenverarbeitung, Bonn.
- Fadell, E. (1970). Recent results in the fixed point theory of continuous maps. *Bull. Am. Math. Soc.* **76**, 10–29.
- Fuks, D.B. (1969). Homotopic topology (in Russian), “Algebra, Topology, Geometry, 1969,” pp. 71–122. Akad. Nauk SSSR, Moscow.
- Glezerman, M., and Pontrjagin, L. (1951). Intersections in manifolds. *Am. Math. Soc. Transl.* **50**, 149 pp.
- Haefliger, A., and Reeb, G. (1957). Variétés à une dimension et structures feuilletées du plan. *Enseignement Math.* (2) **3**, 107–125.
- Haken, W. (1970). Various aspects of the three-dimensional Poincaré problem. “Topology of Manifolds,” pp. 140–152. Markham, Chicago, Illinois.
- Hilton, P.J. (1961). Memorial tribute to J. H. C. Whitehead. *Enseignement Math.* (2) **7**, 107–124.
- Hirsch, G. (1964). Introduction à la topologie algébrique. I. *Bull. Soc. Math. Belg.* **16**, 152–188.
- Hirsch, G. (1966). Introduction à la topologie algébrique. II. Les groupes d'homotopie. *Bull. Soc. Math. Belg.* **18**, 227–244.
- Hirzebruch, F. (1954). Some problems on differentiable and complex manifolds. *Ann. Math.* **60**, 213–236.
- Hirzebruch, F. (1966). Über singularitäten komplexer Flächen. *Rend. Mat. Appl.* **25**, 213–232.
- Holm, P. (1967). Microbundles and S -duality. *Acta Math.* **118**, 271–296.
- Hopf, H. (1950). Die n -dimensionalen Sphären und projektiven Räume in der Topologie. *Proc. Int. Congr. Math. Cambridge* **1**, 193–202.

- Hopf, H. (1951). Über komplex-analytische Mannigfaltigkeiten. *Univ. Roma. Inst. Naz. Alta Mat. Rend. Mat. Appl.* **10**, 169–182.
- Hopf, H. (1952). Einige Anwendungen der Topologie auf die Algebra. Univ. e Politecnico Torino. *Rend. Sem. Mat.* **11**, 75–91.
- Hopf, H. (1953). Vom Bolzanoschen Nullstellensatz zur algebraischen Homotopie-theorie der Sphären. *Jber. Deutsch. Math. Verein.* **56**, 59–76.
- Hopf, H. (1962). Über den Defekt stetiger Abbildungen von Mannigfaltigkeiten. *Rend. Mat. Appl.* (5) **21**, 273–285.
- Hopf, H. (1966). Ein Abschnitt aus der Entwicklung der Topologie. *Jber. Deutsch. Math. Verein.* **68**, 182–192.
- Hu, S.-T. (1947). An exposition of the relative homotopy theory. *Duke Math. J.* **14**, 991–1033.
- Hurewicz, W. (1950). Homotopy and homology. *Proc. Int. Cong. Math. Cambridge* **2**, 344–349.
- James, I.M. (1971). “Bibliography on H -Spaces” (Lecture Notes in Mathematics), Vol. 196, pp. 137–156. Springer-Verlag, Berlin and New York.
- Lashof, R. (1965). Problems in differential and algebraic topology. *Ann. Math.* **81**, 565–591.
- Lee, C.N. (1968). Equivariant homology theories. *Proc. Conf. Transformation Groups* 237–244. Springer-Verlag, Berlin and New York.
- Lefschetz, S. (1968). A page of mathematical autobiography. *Bull. Am. Math. Soc.* **74**, 854–879.
- Mahowald, M.E. (1968). Some remarks on obstruction theory. *Conf. Topological Manifolds* 107–113. Prindle, Weber, and Schmidt, Boston, Massachusetts.
- Massey, W.S. (1954). Some new algebraic methods in topology. *Bull. Am. Math. Soc.* **60**, 111–123.
- Massey, W.S. (1955). Some problems in algebraic topology and the theory of fibre bundles. *Ann. Math.* **62**, 327–359.
- Milnor, J. (1961). A procedure for killing homotopy groups of differentiable manifolds, *Symp. Pure Math.* **3**, 39–55, Differential Geometry. Am. Math. Soc., Providence, Rhode Island.
- Milnor, J. (1961). Differentiable manifolds with boundary (in Spanish). *Ann. Inst. Mat. Univ. Nac. Autónoma México* **1**, 82–116.
- Milnor, J. (1962). A survey of cobordism theory. *Enseignement Math.* (2) **8**, 16–23.
- Milnor, J. (1963). Spin structures on manifolds. *Enseignement Math.* (2) **9**, 198–203.
- Milnor, J. (1964). “Differential Topology” (Lectures on Modern Mathematics), Vol. 2, pp. 165–183. Wiley, New York.
- Milnor, J. (1966). Whitehead torsion. *Bull. Am. Math. Soc.* **72**, 358–426.
- Milnor, J. (1968). Infinite cyclic coverings. *Conf. Topological Manifolds* 115–133. Prindle, Weber & Schmidt, Boston, Massachusetts.
- Milnor, J., and Burelet, O. (1970). Torsion et type simple d’homotopie. “Essays on Topology and Related Topics,” pp. 12–17. Springer Publ., New York.
- Misner, C. (1964). Differential geometry and differential topology. “Relativité, Groupes et Topologie” (Univ. Grenoble-1963), pp. 881–929. Gordon & Breach, New York.
- Munkres, J.R. (1967). Concordance of differentiable structures—Two approaches. *Mich. Math. J.* **14**, 183–191.
- Newman, M.H.A. (1963). Geometrical topology. *Proc. Int. Congr. Math., Stockholm, 1962* 139–146. Inst. Mittag-Leffler, Djursholm.
- Novikov, S.P. (1963). Differential topology (in Russian). “Itogi Nauki” (Algebraic Topology, 1962), pp. 134–160. Akad. Nauk SSSR, Moscow.
- Novikov, S.P. (1965). New ideas in algebraic topology. K -Theory and its applications. *Russian Math. Surveys* **20**, No. 3, 37–62.
- Novikov, S.P. (1966). The Cartan-Serre theorem and inner homologies (in Russian). *Uspehi Mat. Nauk* **21**, No. 5 (131), 217–232.

- Novikov, S.P. (1968). Pontrjagin classes, the fundamental group and some problems of stable algebra. *Am. Math. Soc. Transl.* **70**, 172–179.
- Novikov, S.P. (1968). Rational Pontrjagin classes. Homeomorphism and homotopy type of closed manifolds. I. *Am. Math. Soc. Transl.* **66**, 214–230.
- Olum, P. (1969). Factorizations and induced homomorphisms. *Adv. Math.* **3**, 72–100.
- Palais, R.S. (1970). Critical point theory and the minimax principle. “Global Analysis” (*Proc. Symp. Pure Math.*), Vol. 15, pp. 185–212. Am. Math. Soc., Providence, Rhode Island.
- Papakyriakopoulos, C.D. (1958). Some problems on 3-dimensional manifolds. *Bull. Am. Math. Soc.* **64**, 317–335.
- Papakyriakopoulos, C.D. (1958). The theory of 3-dimensional manifolds since 1950. *Proc. Int. Congr. Math.* 433–440.
- Peterson, F.P. (1968). “Lectures on Cobordism Theory,” Lectures in Mathematics, Kyoto Univ., Vol. 1. Kinokuniya Book Store, Tokyo.
- Peterson, F.P. (1969). Characteristic classes—Old and new. *Bull. Am. Math. Soc.* **75**, 907–911.
- Quillen, D. (1971). Elementary proofs of some results of cobordism theory using Steenrod operations. *Adv. Math.* **7**, 29–56.
- Reid, W.T. (1969). Remarks on the Morse index theorem. *Proc. Am. Math. Soc.* **20**, 339–341.
- Rohlin, V.A. (1963). Theory of intrinsic homologies. *Am. Math. Soc. Transl.* (2) **30**, 255–271.
- Roussarie, R. (1969). Sur les feuilletages des variétés orientables de dimension 3. *Colloque de Topolog. Différentielle, 1969* 50–63. Univ. de Montpellier, Montpellier.
- Seebach, J.A., Seebach, L. A., and Steen, L. A. (1970). What is a sheaf? *Am. Math. Monthly* **77**, 681–703.
- Segal, G. (1968). Equivariant K-Theory. *Inst. Hautes Etudes Sci. Publ. Math.* No. 34, 129–151.
- Shih, W. (1968). Characteristic classes as natural transformations and topological index of classical elliptic operators. *Cahiers Topolog. Géom. Différentielle* **10**, 395–447.
- Smale, S. (1963). A survey of some recent developments in differential topology. *Bull. Am. Math. Soc.* **69**, 131–145.
- Smale, S. (1967). Differentiable dynamical systems. *Bull. Am. Math. Soc.* **73**, 747–817.
- Smale, S. (1968). Differentiable dynamical systems. *Proc. Int. Congr. Math. Moscow, 1966* 139. Izdat. “Mir,” Moscow.
- Smale, S. (1969). Global stability questions in dynamical systems. “Lectures in Modern Analysis and Applications,” Vol. I, pp. 150–158. Springer-Verlag, Berlin and New York.
- Smale, S. (1969). What is global analysis? *Am. Math. Monthly* **76**, 4–9.
- Smale, S. (1970). Notes on differentiable dynamical systems. “Global Analysis” (*Proc. Symp. Pure Math.*), Vol. 14, pp. 277–287. Am. Math. Soc., Providence, Rhode Island.
- Stasheff, J. (1971). “Infinite Loop Spaces—A Historical Survey” (Lecture Notes in Mathematics), Vol. 196, pp. 43–53. Springer-Verlag, Berlin and New York.
- Steenrod, N.E. (1957). The work and influence of Prof. S. Lefschetz in algebraic topology. “Algebraic Geometry and Topology,” pp. 24–43. Princeton Univ. Press, Princeton, New Jersey.
- Steenrod, N.E. (1961). The cohomology algebra of a space. *Enseignement Math.* **7**, 153–178.
- Steenrod, N.E. (1972). Cohomology operations and obstructions to extending continuous functions. *Adv. Math.* **8**, 371–416.
- Sugawara, M. (1968). Introduction to H -spaces (in Japanese). *Sûgaku* **20**, 202–211.
- Thom, R. (1968). Sur les travaux de Stephen Smale. *Proc. Int. Congr. Math., Moscow, 1966* 25–28. Izdat. “Mir,” Moscow.

- Thom, R. (1969). Ensembles et morphismes stratifiés. *Bull. Am. Math. Soc.* **75**, 240–284.
- Thomas, E. (1969). Vector fields on manifolds. *Bull. Am. Math. Soc.* **75**, 643–683.
- Tucker, A.W. (1945). Some topological properties of disk and sphere. *Proc. Can. Math. Congr., 1st, Montreal, 1945* 285–309.
- Wall, C.T.C. (1965). Topology of smooth manifolds. *J. London Math. Soc.* **40**, 1–20.
- Wall, C.T.C. (1968). Homeomorphism and diffeomorphism classification of manifolds. *Proc. Int. Congr. Math. Moscow, 1966* 450–460. Izdat. “Mir,” Moscow.
- Wallace, A.H. (1962). A geometric method in differential topology. *Bull. Am. Math. Soc.* **68**, 533–542.
- Weber, C. (1967). Quelques théorèmes bien connus sur les ANR et les CW complexes. *Enseignement Math. (2)* **13**, 211–220.
- Whitehead, G.W. (1950). Homotopy groups of spheres. *Proc. Int. Congr. Math. Cambridge, 1950* **2**, 358–362.
- Whitehead, G.W. (1970). “The Work of Norman E. Steenrod in Algebraic Topology: An Appreciation” (Lecture Notes in Mathematics), Vol. 168, pp. 1–10. Springer-Verlag, Berlin and New York.
- Whitehead, J.H.C. (1956). Duality in topology. *J. London Math. Soc.* **31**, 134–148.
- Whittlesey, E.F. (1963). Fixed points and antipodal points. *Am. Math. Monthly* **70**, 807–821.
- Wu, Wen-Tsün (1959). Topologie combinatoire et invariants combinatoire. *Colloq. Math.* **7**, 1–8.

Index

- Acyclic model theorem, 125
- Adams, J.F., 30, 140, 227
- Adem, J., 140, 227
- Alexander-Whitney diagonal approximation, 133
- Algebraic mapping cylinder, 167
- Antipodal map, 28

- Back j -face, 133
- Barycenter, 211
 - of affine singular simplex, 214
- Barycentric subdivision, 212
- Base space, 85
- Betti number, 63
- Bilinear form, 176–182
 - antisymmetric, 176
 - nonsingular, 176
 - signature of, 179
 - symmetric, 176
- Bilinear mapping, 65
- Bing, R.H., 218
- Birkhoff, G.D., 209, 227
- Boundary, 5
- Boundary operator, 4
- Brouwer, L.E.J., 25, 34, 186
 - fixed-point theorem, 25
- Brown, M., 169, 218, 227
- Brown, Robert F., 209, 210, 227
- Brown, Ronald, 64, 227
- Brumfiel, G., 185, 227

- Cap product, 140
- Category, 124
- Cellular approximation theorem, 96
- Cellular map, 60
- Chain complex, 5
 - homology, 6
 - quotient of, 44
 - subcomplex of, 44
- Chain homotopy, 12
- Cobordism, 184
 - oriented, 184
 - unoriented, 185
- Coboundary operator, 77
- Cochain complex, 77
 - homotopy, 77
 - map, 77
- Cocycle, 78
- Coefficient group, 75
- Cohomology group, 78
 - de Rham, 207
 - singular, 78
- Coincidence, 188
 - class, 195
 - index, 189
 - number, 188
 - theorem, 198
- Collaring theorem, 169
- Commutative graded R -algebra, 132
- Cone, 214
- Connelly, R., 218, 223, 227

- Connecting homomorphism, 19
- Convex, 1
- Convex hull, 1
- Coordinate neighborhood, 149
- Covering map, 85
- Covering projection, 85
- Covering space, 85
 - automorphism of, 103
 - isomorphism of, 102
 - map of, 102
- Cross section, 99
- Cup product, 132
- Curvature, 207
- Cycle, 5

- Deformation retract**, 17
 - strong, 49
- Degree**
 - of antipodal map, 28
 - of chain map, 5
 - local, at fixed point, 194
 - of a loop, 95
 - of map of manifolds, 186
 - of map of spheres, 25
- de Rham, 183
 - theorem, 207
- Derivation property, 129
- Diagonal, 36
- Diagonal approximation, 133
- Diameter, 211
- Directed set, 30
- Direct limit, 30
- Direct product, 8
- Direct sum, 8
- Direct system, 30
- Disk, 24
- Dold, A., 189, 218, 227
- Double of M , 169
- Dual cell, 143

- Eckmann, B.**, 29, 227
- Eilenberg, S.**, 74, 140, 167, 227
- Eilenberg–Steenrod axioms**, 74
 - uniqueness theorem, 75
- Eilenberg–Zilber theorem**, 128
- Epstein, D.B.A.**, 84, 228
- Equivalence relation, 8, 35
 - generated, 37
 - graph of, 36
- Euclidean half-space, 146
- Euler characteristic, 63, 188
- Euler class, 188

- Exact sequence, 17
 - long, 19
 - short, 17
 - split, 48
- Excision theorem, 46
- Exp (exponential map), 86
- Ext, 79
- External product
 - cohomology, 130
 - homology, 128

- Face, 3
- Fadell, E., 209, 227
- Finite CW complex, 54
 - subcomplex, 56
- Five lemma, 46
- Fixed-point index, 191
- Fixed-point theorem, 199
- Flow, 207
 - fixed point of, 208
- Free abelian group, 3
- Free product, 115
 - amalgamated, 115
- Free resolution, 70
- Front i -face, 133
- Functor, 124
 - contravariant, 124
 - covariant, 124
 - free, with respect to models, 125
 - natural transformation of, 124
- Fundamental class, 156
 - of manifold with boundary, 169
- Fundamental group, 92
- Fundamental neighborhood, 85
- Fundamental theorem of algebra, 204
- Fundamental theorem of calculus, 80

- Gauss–Bonnet theorem**, 207
- Generalized homology theory, 77
- Graded abelian group, 5
 - of finite type, 141
- Gray, B., 115, 227

- Hodge, W.V.D.**, 183
- Hom, 77
- Homology group, 6. *See also* Singular homology group
- Homology theory, 74
 - generalized, 77
- Homomorphism of covering spaces, 102

- Homotopy, 13
 - equivalence, 16
 - inverse, 16
 - of map of pairs, 45
 - type, 16
- Hopf, H., 25
- Hopf invariant, 135–140
 - for Hopf maps, 176
- Hopf map, 42
- Horizontal circle, 86
- Hu, S.-T., 140, 227
- Hurewicz homomorphism, 107
- Hurwitz and Radon, 29

- Index**
 - of fixed point, 186
 - of manifold, 179
 - of vector field, 206
- Integral coefficients, 71
- Interior, 19
- Invariance of domain, 34
- Isotopy, 152

- Jordan-Brouwer separation theorem, 33

- Kirby, R., 185, 227
- Knot, 118
 - group of, 119
 - torus, 119
 - unknotted, 119
- Kronecker index, 81
- Künneth formula
 - for chain complexes, 123
 - for singular cohomology, 141
 - for singular homology, 128

- Lebesgue number, 90
- Lefschetz, S., 44, 186, 227
 - class, 195
 - coincidence theorem, 198
 - fixed-point theorem, 187, 199
 - number, 187, 195
- Lifting problem, 87
- Lifting theorem, 97
- Locally pathwise connected, 85
- Long exact sequence, 19

- Madsen, I., 185, 227
- Manifold, 146

- Maps of pairs, 45
- Massey, W.S., 105, 106, 115, 227, 228
- Mayer-Vietoris sequence, 22
- Mesh, 211
- Milgram, R.J., 185, 227
- Milnor, J.W., 84, 158, 206, 218, 228
- Möbius band, 89
- Models, 125
- Morphism, 124
- Mosher, R.E., 84, 228
- Multiplicity, 106

- Orientation, 156
 - double covering, 156
 - of manifold with boundary, 169

- Pair of spaces, 45
- Path components, 9
- Pathwise connected, 7
- Poincaré group, 92
- Poincaré, H., 186, 209
 - duality theorem, 143, 165–168
 - last geometric theorem of, 208
 - relative form, 171
- Poincaré-Hopf theorem, 206
- Poincaré-Lefschetz duality theorem, 171
- Projective space
 - complex, 41
 - quaternionic, 42
 - real, 37, 40
- Proper n -ball, 155
- Pushout, 114

- Quotient function, 35

- Rank of finitely generated abelian group, 63
- Rational homology sphere, 201
- Regular covering space, 105
- Relative homeomorphism, 51
- Relative homology group, 45
- Retraction, 16
- Right exact functor, 69

- Samelson, H., 143, 189, 228
- Segment, 1
- Semilocally simply connected, 105
- Siebenmann, L., 185, 227
- Short exact, 17

- Simplex, 1
 - ordered, 2
 - singular, 2
 - standard, 2
- Simply connected, 91
- Singer, I.M., 207, 228
- Singular chain, 4
 - of (X, A) , 45
- Singular cohomology group, 78
 - reduced, 81
 - of sphere, 83
- Singular cohomology ring
 - of complex projective space, 175
 - of quaternionic projective space, 176
 - of real projective space, 175
 - of torus, 135
- Singular homology group, 78
 - additive property of, 9
 - with coefficients in G , 71
 - of complex projective space, 43
 - of generalized torus, 43
 - of point, 7
 - of quaternionic projective space, 43
 - of real projective space, 63
 - reduced, 48
 - relative, 45
 - of sphere, 24
 - topological invariance, 10
- Singular simplex, 2
 - affine, 213
- Skeletal chain complex, 58
- Skeleton, 54
- Spanier, E.H., 105, 115, 228
- Sphere, 23
- Spherical class, 43
- Split exact, 48
- Star of vertex, 143
- Steenrod, N.E., 74, 84, 140, 167, 227, 228
- Stong, R., 185, 228
- Suspension, 27
- Tangora, M.C., 84, 228
- Tensor product, 66
 - of chain complexes, 120
- Thom class, 161
- Thom isomorphism theorem, 160-162
 - for circle, 162
- Thorpe, J.A., 207, 228
- Topological cobordism ring, 185
- Topological manifold, 146
- Tor, 70
- Torus, 41
- Total space, 85
- Universal coefficient theorem, 73
- Universal covering space, 105
- Universal mapping property, 105
- Van Kampen theorem, 115
- Vector field, 29
- Vertex, 2
- Vertical circle, 87
- Volume element, 207
- Wedge, 40
- Whitehead, J.H.C., 136

This book is designed to be an introduction to some of the basic ideas in the field of algebraic topology. In particular, it is devoted to the foundations and applications of homology theory. The only prerequisite for the student is a basic knowledge of abelian groups and point set topology. The essentials of singular homology are given in the first chapter, along with some of the most important applications. In this way the student can quickly see the importance of the material. The successive topics include attaching spaces, finite CW complexes, the Eilenberg-Steenrod axioms, cohomology products, manifolds, Poincaré duality, and fixed point theory. Throughout the book, the approach is as illustrative as possible, with numerous examples and diagrams. Extremes of generality are sacrificed when they are likely to obscure the essential concepts involved. The book is intended to be easily read by students as a textbook for a course or as a source for individual study. This second edition has been expanded to include a new chapter on covering spaces, as well as additional illuminating exercises. The conceptual approach is again used to show how lifting problems give rise to the fundamental group and its properties.

ISBN 0-387-94126-6
ISBN 3-540-94126-6